

C-2

MEDIUM VOLTAGE CABLES

**CROSS-LINKED
POLYETHYLENE
INSULATION**

Engineering Data for
Copper and Aluminium
Conductors

Cables design	page 2
Introduction	3
Technical standards	
Key cables code	
Cables marking	
Electrical metallic conductors	4
Metal conductor replacement	5
Electrical insulation stress	
Special performance cables	6
Alternative kind cables	7
Metallic armour cables	8
AWG calculation	
Quality System	9
Conditions for current ratings	
Selection cables for alternative current system	
Range and dimensions 3.6/6 kV	10-11
Range and dimensions 6/10 kV	12-13
Range and dimensions 8.7/15 kV	14-15
Range and dimensions 12/20 kV	16-17
Range and dimensions 18/30 kV	18-19
Range and dimensions 26/45 kV	20-21
Apparent electric resistance of the conductor	22
Capacity values	
Phase reactance values	23
Group rating factors	24-25
Electrical formulas	26
Final tests	27
Storage and handling	28
Installation	28-29
Packaging	29-30
Glossary	31

SINGLE CORE CABLE

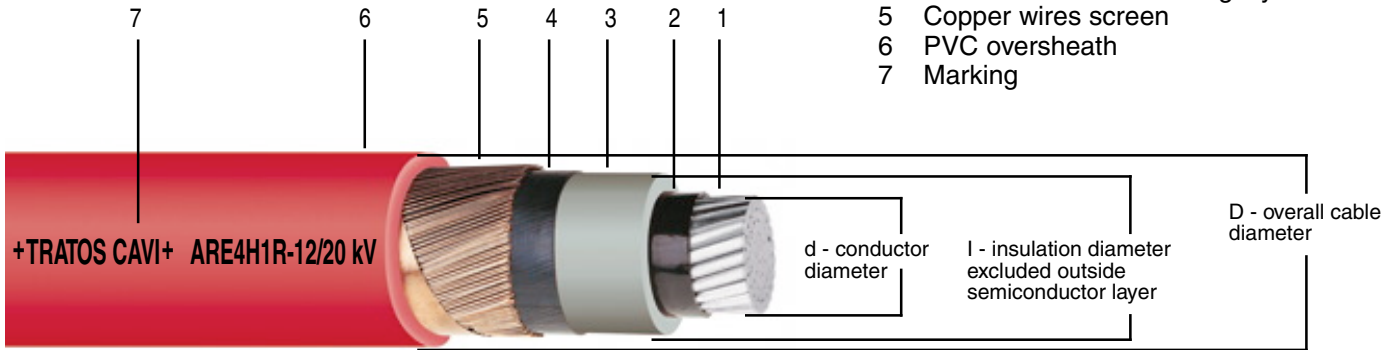

- 1 Copper or aluminium circular stranded compacted conductor
- 2 Extruded semi-conducting lay
- 3 XLPE insulation
- 4 Extruded semi-conducting layer
- 5 Copper wires screen
- 6 PVC overshath
- 7 Marking

THREE CORES CABLE

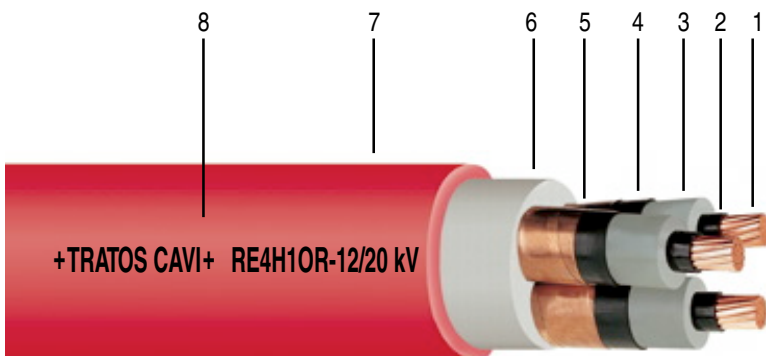

- 1 Copper circular stranded compacted conductor
- 2 Extruded semi-conducting layer
- 3 XLPE insulation
- 4 Extruded semi-conducting layer
- 5 Copper tapes screen
- 6 Not hygroscopic filler
- 7 PVC overshath
- 8 Marking

THREE CORES ARMoured CABLE

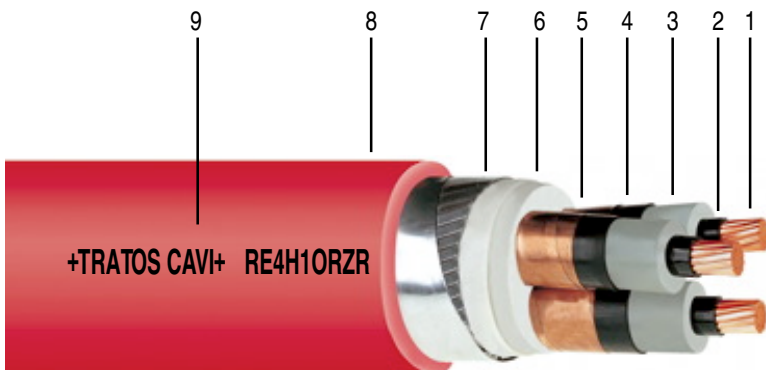

- 1 Copper or aluminium circular stranded conductor
- 2 Extruded semi-conducting layer
- 3 XLPE insulation
- 4 Extruded semi-conducting layer
- 5 Copper tapes screen
- 6 Not hygroscopic filler
- 7 Galvanized steel flat wire armour
- 8 PVC overshath
- 9 Marking

INTRODUCTION TO MEDIUM VOLTAGE CABLES

This booklet is designed to help engineers in the selection of conductors sizes and in the installation of cables system.

The information provide general cross sectional area, outside diameter, weight, bending radius and handling cables. Besides you can select the ampacity of a cable and the various factors given for any installation condition varying from those for which the tables where calculated.

Basic data has been calculated in compliance of the conditions as **page 9**.

Furthermore detailed information may be requested directly to our customer's assistance service office. Please to take into consideration many alternative kind cables with special performances as described on **pages 4, 5, 6, 7 and 8**.

We are available to produce cables with AWG conductors size, as shown on **page 8**, to employ by end-user operating out from metric-system area.

TECHNICAL STANDARDS

IEC 60502-2	Power cables with extruded insulation up to 30 kV (Um 36 kV) U ₀ /U (Um) 3.6/6(7.2) kV 6/10(12) kV 8.7/15(17.5) kV 126/20(24) kV 18/30(36) kV
IEC 60840	Power cables with extruded insulation for rated voltages above 30 kV (Um 36 kV) up to 150 kV (Um 170 kV) U ₀ /U (Um) 26/45(52) kV
IEC 60228	Conductor of insulated cables
IEC 60332-1	Test for vertical flame propagation for single insulated wire or cable
EN 50265	Test for vertical flame propagation for a single insulated wire or cable
IEC 60287	Calculation of the current rating
CEI 11-17 <small>(domestic standard)</small>	Generation, trasmission and distribution system of electric power - (domestic standard) Cables installation

KEY CABLES CODE

A	Aluminium conductor	O	Mean three phases under the same outersheath
R	Conductor class 2 (without any lettere before R mean copper conductor)	A	Steel braid armour
E4	XLPE polyethylene insulation	AH6	Corrugated aluminium tape electrowelded
G7	HEPR high ethylene propylene rubber insulation	H6	Corrugated steel tape electrowelded
H1	Tapes or wires copper screen	H9	Corrugated steel tape thermosealed
H5	Longitudinally thermosealed aluminium tape	Z	Flat steel wires armour
R	PVC - polyvinyl chloride sheath	N	Steel tapes armour
E	Polyethylene sheath	NA	Aluminium tapes armour
M1	LS0H - low smoke zero halogen compound	F(SWA)	Steel wires armour
		FA(AWA)	Aluminium wires armour
		X	Mean three single sheathed cables assembled together

CABLES MARKING

In order to provide the cable type identification , cable-maker and generally its traceability in compliance of **Quality Guarantee** rules, any cables has an entire code continually printed or engraved or embossed on the outer-sheath.

+TRATOS CAVI+	ARE4H1R-12/20 kV	1X240 mm²	IEC 60502-2	4/2007	999
facility location	cable code	conductor number and size	technical standards	lot number and production year	metric marking
cable manufacturer name		rated voltage U ₀ /U			

Copper and aluminum are the most employed metals for conductors in the cables power production technology. Their application is due to different parameters as electric conductivity, density (mass per unit volume), breaking load and elongation, malleability, thermal conductivity, elastic module and finally metal cost-effective. The shape of conductors and their rigidity or flexibility is designed in consideration of the final application and of the rated voltage cable.

For medium tension cable is very important a smooth outside surface metal conductor to reduce electrical insulation stress. For the purpose any MT conductor is compacted by special tools suitable to calibrate outside diameter and surface. In all tables we report the nominal cables section expressed in mm² but the real conductor size considered is defined **Electrical Section** that is guaranteed by means of check of the maximum appropriate electrical resistance at 20°C in compliance of technical standards.

- 1- class 2 round stranded not compacted
- 2- class 2 round stranded compacted
- 3- class 5 uniform bunched wires
- 4- class 2 round compacted water blocking
- 5- class 1 round solid
- 6- class 1 shaped solid
- 7- class 1 shaped stranded

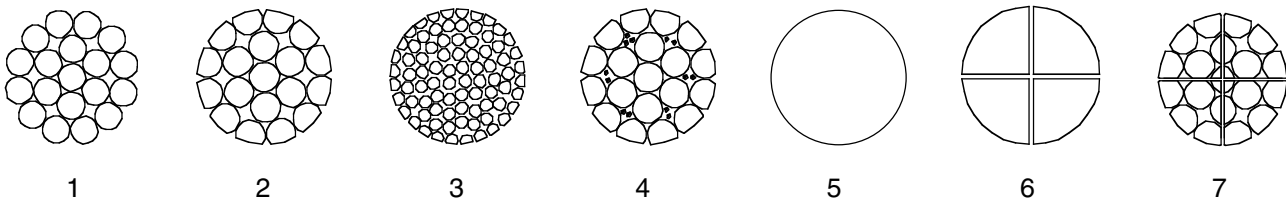

METAL CHARACTERISTICS

When is necessary to improve a few basic metal characteristics is possible to lose or reduce significant other properties. However typical metal characteristics ordinary way contemplated, over any global evaluation, are indicated in the table below.

Copper results to hold the greatest electrical conductivity but despite that its price may be still high if compared with aluminium for example. Following information help you a fully technical evaluation.

CHARACTERISTICS	UNITS	ANNEALED COPPER	HARD COPPER	ALUMINIUM (3/4 HARD)	ALUMINIUM ALLOY	LEAD	STEEL
code		Cu-ETP		Al 99.5			
chemical symbol		Cu	Cu	Al	-	Pb	Fe
density	Kg/dm ³	8.89	8.89	2,7	2.7	11.35	7.8
resistivity at 20°C	Ohm.km/mm ²	17.241	17.586	28.264	32.50	206	190
electric conductivity	% IACS*	100	98	61	53	8.4	9
thermal conductivity	W/cm.k	3.893	3.893	2.218	1.84	0,35	0.46
breaking load	daN/mm ²	20-30	35-50	12-15	35-40	1.75	40-150
breaking elongation	%	25-30	0.5-3	1.5-3	4-6	20-50	2-6
elastic module	daN/mm ²	10500	12000	5600	6000	1700	18500
melting temp.	°C	1083	1083	657	657	327	1400
specific heat	Cal/°C.g	0.093	0.093	0.214	0.214	0.030	0.114
temp. variation coef.	k-1	0.00393	0.00393	0.00403	0.0036	0.0042	0.004
linear dielectric coef.	k-1 (x 10-6)	17	17	23	23	29	11.5

* International Annealed Copper standard

METAL CONDUCTOR REPLACEMENT

Strictly connected to metal market price an important save money may be achieved by to use aluminium cables instead of copper cables. In this case a calculation of aluminium conductor size, bigger than copper, is possible by electrical equivalence formula:

Cu resistivity	0.017241 Ohm • mm ² /m at 20° C	= 0.61
Al resistivity	0.028264 Ohm • mm ² /m at 20° C	

Due to the above equivalence how to change an aluminium cable in a copper cable and contrariwise:

example

Al cable size 240 mm² • 0.61 = 146.40 mm² Cu (mathematical size)
consequently the nearest available standard size to use is **150 mm² Cu**

Cu cable size 240 mm² : 0.61 = 393.44 mm² Al (mathematical size)
consequently the nearest available standard size to use is **400 mm² Al**

ELECTRICAL INSULATION STRESS

The XLPE insulation is extruded simultaneously with the conductor screen and the insulation screen. The surfaces between inner semiconductor layer and XLPE insulation and between insulation and outside semiconductor layer are not exposed to environment conditions. Triple and dry curing extrusion guarantee high products quality. It is known that the electrical stress is maximum at the conductor level surface and decrease drawing up outside insulation layer.

In order to avoid stress peak in the medium voltage cable compacted metallic conductors with homogeneous and smooth surface are employed. Besides that the extruded conductor screen allows an uniform electric field which contributes for a long duration cable life.

The insulation thickness may be calculated by following formula.

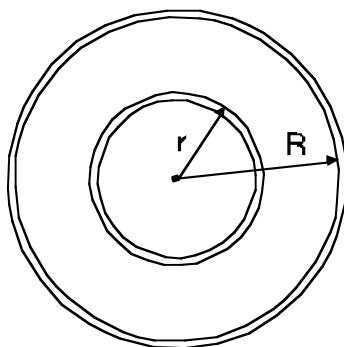

$$E_x = \frac{U_0}{x \ln (R/r)} \text{ kV/mm}$$

R radius under insulation screen
r radius over conductor screen
U₀ voltage across insulation

INSULATION STRESS VALUE

example 18/36 kV

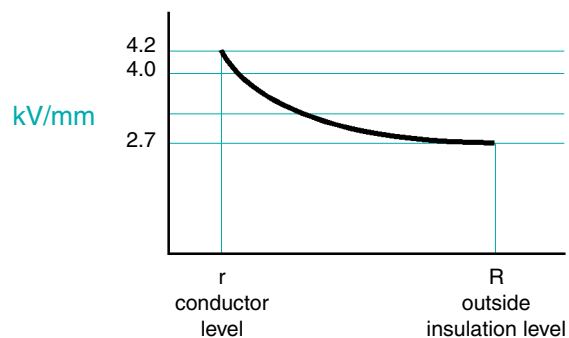

FLAME RETARDANT - LOW SMOKE - ZERO HALOGENS (LS0H)

Fire is one of the most danger for popolations and equipments especially inside structures and in any place where it may happen. Very frequently that is due to the very extensive use of cables. They can be an important components to trigger fire, carry flames everywhere, developping acid gasses and dark fumes very hazardous for persons.

In consideration of past tragic happenings have been developped special cables with particular performances reaction to fire as to design cables with components able to avoid issue aggressive substances underburnings event without loosing or altering any basic feature.

Flame Retardancy - cables in compliance of standards country regualtions suitable to overcome special restrict propagation test on single cable or bunched cables with definite volium per meter of non metallic material. Its behaviour is strictly related to the combustion quantity material exposed to the flame, temperature and aeration.

Corrosivity Combustion Gasses - not LS0H during combustion develop great quantities of corrosive and toxic gasses. New generation cables reduce or entirely remove it.

Intensity and Dark Smoke - under fire conditions not LS0H cables release dark smokes that prevent people evacuation, that has been restricted ta lot, as a special test able to verify residue light across the smokes shows.

EN 50265 Test for resistance to vertical flame propagation for a single insulated conductor or cable
IEC 60332-1

EN 50266 Test for vertical flame spread of vertically-mounted bunched wires or cables
IEC 60332-3

EN 50267 Test on gases evolved during combustion of materials from cables
IEC 60754

EN 61034 Measurement of smoke density of cables burning under defined conditions
IEC 61034

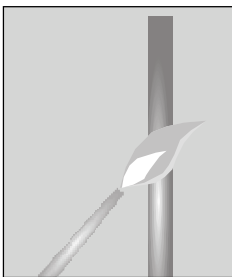

EN 50265
IEC 60332-1



EN 50266
IEC 60332-3

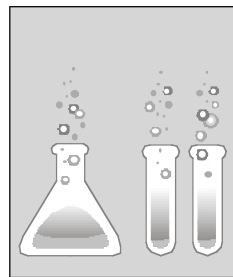

EN 50267
IEC 60754

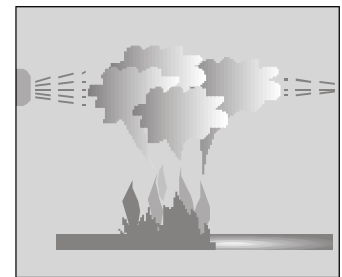

EN 61034
IEC 61034

Alternative kinds of cable are possible to be engineered in order to ensure a long term service with large tolerability for specific working conditions as dry and wet ground, rain and snow, under-water without any cover, direct exposition to the sun, places where cables can be crashed into etc.

Electromagnetic Fields (EMF) are one of the most technical matters that affect environment condition that may be supervised by an appropriate increase of the cable metallic screen.

- 1- Particularly eligible for installations in contact with water and moisture contact thanks to longitudinally thermosealed aluminium tape screen absolute safety of transverse tightness.
- 2- In any habitat place where a limited a EMF level is required we provide through the electrical balance of conductor and cable screen.
- 3- **Root Cable** is a commercial brand cable in aluminium or copper conductor with a non metallic mechanical protection made-up of an under outsheath plastic layer able to cushion heavy blow and to safeguard the below metallic cable screen.

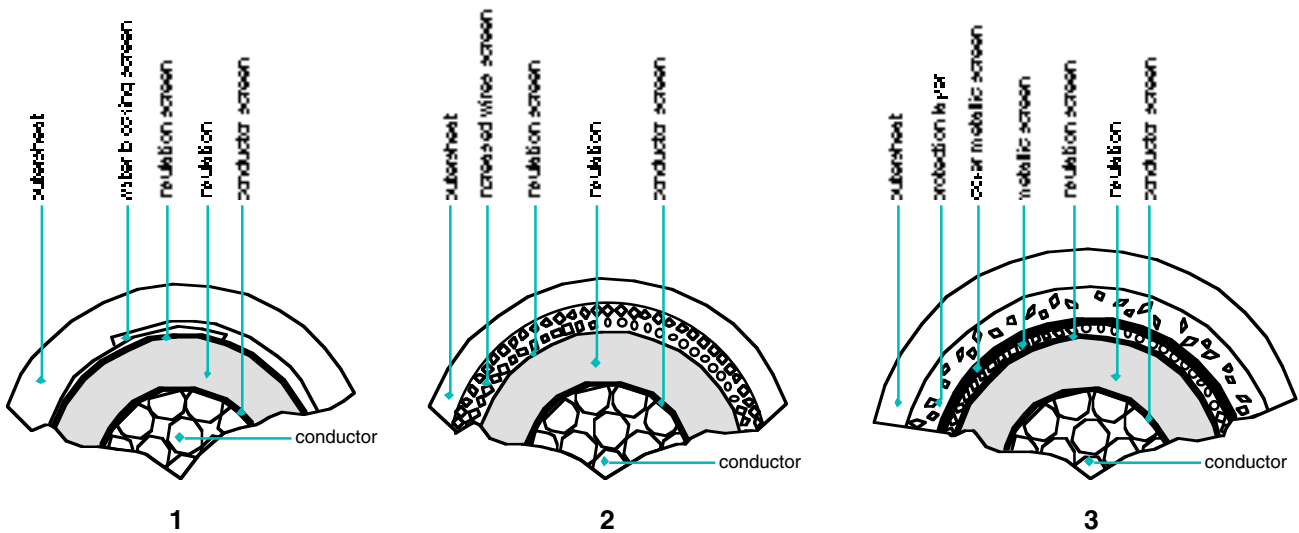

- 4- Self supporting cables for overhead installations through aluminium steel cladding rope laid in the central of three single phases. That rope can be replaced with a non metallic rope. This involves a new cable design with an increase screen size to allow electrical current fault discharge.
- 5- Three-phases underground cable with additional cables service.
- 6- Composite MT and FO cable where three-phases power elements and telecommunication aggregate fiber optic cable able to work under the same outsheath.

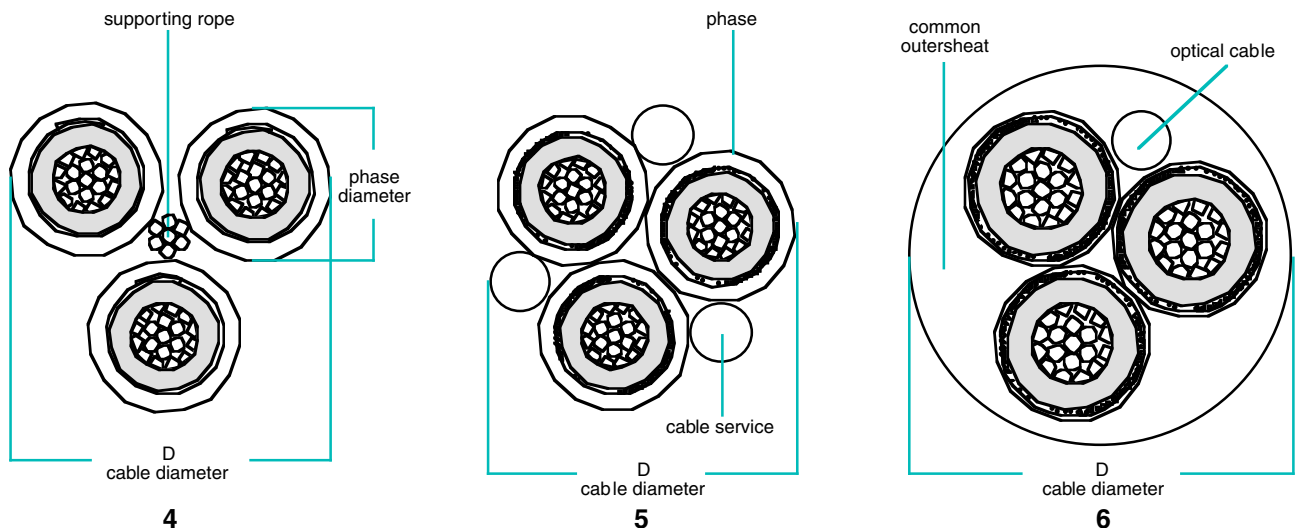

METALLIC ARMOUR CABLES

A few different types of armour can be designed as protection of cables against crabs ,blow, shock, cuts, abrasions etc. Furthermore in order to avoid electrical induction in the single phase cables the armour must be made-up of non-magnetic metals as copper, aluminium, bronze etc..

Steel braid armour - a few group of wires braided together in opposite way.

Wires armour - a layer of round wires.

Tapes armour - double tapes wrapped in the same direction in open helics, the second one to cover underlyings space.

Corrugated armour - a single longitudinally smooth tape corrugated by a special tool.

Flat wires armour - a layer of wrapped flat wires with a contrary tape wrapped in open helics.



A steel braid armour

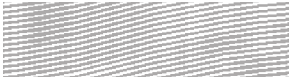

F (SWA) a layer of wrapped steel round wires
FA (AWA) a layer of wrapped aluminium round wires



N double steel tapes wrapped in open helics, the second one to cover underlyings space
NA double aluminium tapes wrapped in open helics, the second one to cover underlyings space



AH6 longitudinally overlapping corrugate aluminium tape
H6 longitudinally overlapping corrugate steel tape electrowelded
H9 longitudinally overlapping corrugate steel tape thermosealed



Z a layer of wrapped steel flat wires with a contrary steel tape wrapped in open helics

AWG CALCULATION

For any operator in a market where there is in force AWG system the following table can be used to turn mm² to AWG or CM and contrariwise. Please keep in consideration some ineluctable approximate calculation due to standard metric system size.

Approximate parallel square-mm to AWG					AWG reference	Conversion AWG to square-mm				
Stand. size mm ²	Elec. resist. Ohm/km 20°C Cu	Elec. resist. Ohm/km 20°C Al	CM (circ.mil)	approx. diam. mil *		approx. diam. mil *	CM (circ.mil)	Elec. resist. Ohm/km 20°C Cu	Elec. resist. Ohm/km 20°C Al	Stand. size mm ²
10	1.83	3.08	19735	162.3	8 AWG	148.4	16510	3.68	2.19	8.366
16	1.15	1.91	31576	205.2	6 AWG	187.1	26251	2.29	1.38	13.302
25	0.727	1.20	49338	256.6	4 AWG	236.0	41741	1.418	0.859	21.151
35	0.524	0.868	69073	303.6	2 AWG	297.6	66371	0.903	0.545	33.631
50	0.387	0.641	98676	362.8	1 AWG	334.1	83693	0.756	0.456	42.408
70	0.268	0.443	138147	429.3	3/0 AWG	473.1	167806	0.365	0.220	85.029
95	0.193	0.320	187485	500.1	4/0 AWG	531.3	211600	0.283	0.171	107.219
120	0.153	0.253	236823	562.1	5/0 AWG	596.6	266823	0.224	0.136	135.219
150	0.124	0.206	296029	628.4	6/0 AWG	670.0	336457	0.181	0.109	170.485
185	0.0991	0.164	365102	697.9	7/0 AWG	752.3	424265	0.141	0.0852	214.978
240	0.0754	0.125	473646	794.9	8/0 AWG	844.8	534988	0.111	0.0667	271.082
300	0.0601	0.100	592058	888.7	9/0 AWG	948.7	674607	0.0877	0.0527	341.829
400	0.0470	0.0778	789410	1026.2	10/0 AWG	1065.3	850664	0.0721	0.0436	431.038
500	0.0366	0.0605	986763	1147.3	11/0 AWG	1196.2	1072668	0.0556	0.0336	543.529
630	0.0283	0.0469	1243321	1287.9	12/0 AWG	1343.3	1352609	0.0431	0.0260	685.377
800	0.0221	0.0367	1578820	1451.3	13/0 AWG	1508.4	1705608	0.0339	0.0205	864.244
1000	0.0176	0.0291	1973525	1622.6	14/0 AWG	1693.9	2150732	0.0267	0.0161	1089.792
1200	0.0151	0.0247	2368230	1777.4	15/0 AWG	1902.1	2712023	0.0216	0.0132	1374.202
1400	0.0129	0.0212	2762935	1919.9	15/0 AWG	1902.1	2712023	0.0216	0.0132	1374.202
1600	0.0113	0.0186	3157640	2052.4	16/0 AWG	2135.9	3419798	0.0171	0.0104	1732.837
1800	0.0101	0.0165	3552345	2176.9	16/0 AWG	2135.9	3419798	0.0171	0.0104	1732.837
2000	0.0090	0.0149	3947050	2294.7	17/0 AWG	2398.5	4312286	0.0136	0.0082	2185.068

*stranded conductor

Our Quality System management includes two certificates: **BSI** and **Aenor** (E), in accordance with ISO 9001 covering the production, purchasing of raw materials, design and final test including various document typologies. Tratos Quality System management is under constant control by auditing inspectors.



CONDITIONS FOR CURRENT RATINGS

Current ratings values stated in the following schedules have been calculated in compliance with IEC 60287 standard.

Current ratings values refer to the following conditions:

Conductor maximum temperature	90° C
Ambient temperature for installation in open air	30° C
Ambient temperature for underground installation	20° C

Laying depths

mt. 0.8	for voltages	U = 3.0÷10kV
mt. 1.0	for voltages	U = 15÷30kV
mt. 1.2	for voltages	U = 45kV

Thermal resistivity (R_t)

ground	100 and 200° C · cm/W
HEPR insulation	450° C · cm/W
PVC oversheath	500° C · cm/W

The metallic screen (6 mm² standard size), jointed together, are connected to earth.

SELECTION OF CABLES FOR ALTERNATIVE CURRENT SYSTEM

Three-phases system characteristics				Insulation rating cables	
nominal tension U (kV)	maximum tension Um (kV)	class	maximum time for each test with grounded phase*	with screen on the single core U ₀ (kV)	without screen on the single-core U ₀ /U kV
3	3.6	B	over 8 h	1.8	1.8/3
6	7.2	A	up to 8 h	3.6	3.6/6
		B	over 8 h	6	–
10	12	A	up to 8 h	6	–
		B	over 8 h	8.7	–
15	17.5	A	up to 8 h	8.7	–
		B	over 8 h	12	–
20	24	A	up to 8 h	12	–
		B	over 8 h	15	–
30	36	A	up to 8 h	18	–
		B	over 8 h	26	–
45	52	A	up to 8 h	26	–
		B	over 8 h	30	–

U₀ = relates to the nominal tension between a conductor and earth
 U = relates to the nominal tension between the conductors of the cable
 U_m = maximum tension for which the cable is suitable

* The whole annual period must be established in consideration of the environmental conditions

SINGLE-CORE RE4H1R-3.6/6 kV - ARE4H1R-3.6/6 kV

nominal area conductor mm ²	conductor diameter d mm.	insulation thickness mm.	nominal overall diameter D mm.	maximum overall diameter mm.	approximate cable weight kg/km		minimum bending radius mm.
					Cu	Al	
1x 10	3.8	2.3	12.2	14.0	310	248	196
1x 16	4.7	2.3	14.0	15.0	373	274	210
1x 25	5.9	2.3	15.6	17.0	463	308	238
1x 35	7.0	2.5	21.0	22.0	744	527	310
1x 50	8.2	2.5	22.2	22.2	909	594	320
1x 70	9.9	2.5	23.9	24.9	1133	692	350
1x 95	11.5	2.5	25.5	26.5	1397	799	370
1x120	12.9	2.5	27.0	28.0	1664	909	390
1x150	14.2	2.5	28.5	29.5	1980	1035	410
1x185	16.2	2.5	30.5	31.5	2347	1182	440
1x240	18.2	2.6	33.0	34.0	2927	1416	470
1x300	21.2	2.8	36.6	37.6	3599	1710	530
1x400	23.4	3.0	39.3	40.3	4602	2083	560
1x500	27.3	3.2	44.0	45.0	5694	2545	630
1x630	30.5	3.2	47.4	48.4	6995	3028	670

THREE-CORES RE4H10R-3.6/6 kV - ARE4H10R-3.6/6 kV

nominal area conductor mm ²	conductor diameter d mm.	insulation thickness mm.	nominal overall diameter D mm.	maximum overall diameter mm.	approximate cable weight kg/km		minimum bending radius mm.
					Cu	Al	
3x 10	3.8	2.3	24.2	24.7	966	780	346
3x 16	4.7	2.3	24.7	26.2	1251	954	367
3x 25	5.9	2.3	29.8	31.3	1640	1175	438
3x 35	7.0	2.5	41.0	42.5	2726	2075	590
3x 50	8.2	2.5	43.8	45.3	3337	2393	630
3x 70	9.9	2.5	47.7	49.2	4181	2859	690
3x 95	11.5	2.5	51.3	52.8	5147	3352	740
3x120	12.9	2.5	54.5	56.0	6100	3832	780
3x150	14.2	2.5	57.4	58.9	7174	4340	820
3x185	16.2	2.5	62.2	63.7	8562	5067	890
3x240	18.2	2.6	67.4	68.9	10571	6037	960

ARMOURED THREE-CORES RE4H10ZR-3.6/6 kV - ARE4H10ZR-3.6/6 kV

nominal area conductor mm ²	conductor diameter d mm.	insulation thickness mm.	nominal overall diameter D mm.	maximum overall diameter mm.	approximate cable weight kg/km		minimum bending radius mm.
					Cu	Al	
3x 10	3.8	2.3	29.2	30.7	1568	1382	430
3x 16	4.7	2.3	31.4	33.9	1880	1415	461
3x 25	5.9	2.3	32.5	34.0	2184	1719	476
3x 35	7.0	2.5	46.1	47.6	3865	3214	670
3x 50	8.2	2.5	48.9	50.4	4335	3590	706
3x 70	9.9	2.5	53.0	54.5	5536	4214	760
3x 95	11.5	2.5	56.6	58.1	6600	4805	810
3x120	12.9	2.5	59.8	61.3	7646	5379	860
3x150	14.2	2.5	62.7	64.2	8773	5939	900
3x185	16.2	2.5	67.5	69.0	10312	6817	970
3x240	18.2	2.6	72.7	74.2	12437	7903	1040

CONTINUOUS CURRENT RATINGS (ampere)

nominal area conductor	ground laying								air laying			
	R _t =100 °C cm/W				R _t =200 °C cm/W							
	mm ²	Cu ... Al	Cu .. Al	Cu ... Al	Cu .. Al	Cu ... Al	Cu .. Al	Cu ... Al	Cu .. Al	Cu ... Al	Cu .. Al	
1x 10	119	97	114	92	95	79	89	73	127	102	106	85
1x 16	140	112	135	108	110	92	105	86	150	120	125	101
1x 25	166	133	158	127	128	106	122	100	177	142	147	118
1x 35	195	150	185	146	151	123	141	113	208	152	173	138
1x 50	232	182	220	172	175	139	166	130	240	190	199	151
1x 70	286	221	268	209	216	167	203	156	300	240	242	194
1x 95	341	256	322	250	257	201	242	188	380	290	314	231
1x120	388	302	368	285	289	230	272	214	430	334	360	270
1x150	430	339	411	327	325	255	306	245	498	398	415	327
1x185	487	385	467	364	365	289	341	270	585	450	495	368
1x240	565	442	540	416	421	327	400	307	683	525	579	469
1x300	640	508	610	477	473	376	450	352	790	630	672	527
1x400	726	580	692	548	535	426	511	402	905	730	770	613
1x500	815	652	764	617	597	478	569	450	1019	857	817	725
1x630	913	745	873	711	667	551	640	522	1200	1000	1020	847

CONTINUOUS CURRENT RATINGS (ampere)

nominal area conductor	ground laying				air laying	
	R _t =100 °C cm/W		R _t =200 °C cm/W			
	mm ²	Cu	Al	Cu	Al	Cu
3x 10	115	94	78	64	93	81
3x 16	135	111	94	77	117	98
3x 25	159	130	115	94	146	120
3x 35	187	150	140	115	182	146
3x 50	221	172	170	133	219	174
3x 70	273	210	212	162	275	213
3x 95	322	250	249	193	335	259
3x120	363	285	280	220	362	298
3x150	405	320	313	248	430	330
3x185	469	359	363	275	495	380
3x240	520	415	399	329	583	450

CONTINUOUS CURRENT RATINGS (ampere)

nominal area conductor	ground laying				air laying	
	R _t =100 °C cm/W		R _t =200 °C cm/W			
	mm ²	Cu	Al	Cu	Al	Cu
3x 10	112	91	76	62	90	78
3x 16	130	107	91	75	113	95
3x 25	154	126	111	91	142	116
3x 35	180	150	149	112	176	145
3x 50	220	163	182	131	212	170
3x 70	259	208	209	169	260	210
3x 95	307	239	247	193	320	243
3x120	350	268	280	212	360	298
3x150	405	310	327	249	430	330
3x185	450	348	362	282	490	380
3x240	528	400	428	322	560	437

SINGLE-CORE RE4H1R-6/10 kV - ARE4H1R-6/10 kV

nominal area conductor mm ²	conductor diameter d mm.	insulation thickness mm.	nominal overall diameter D mm.	maximum overall diameter mm.	approximate cable weight kg/km		minimum bending radius mm.
					Cu	Al	
1x 10	3.8	3.4	17.7	18.7	403	341	262
1x 16	4.7	3.4	19.5	20.6	581	482	289
1x 25	5.9	3.4	21.0	22.2	664	509	315
1x 35	7.0	3.4	22.8	23.8	819	602	330
1x 50	8.2	3.4	24.0	25.0	993	678	350
1x 70	9.9	3.4	25.7	26.7	1237	796	370
1x 95	11.5	3.4	27.3	28.3	1506	908	390
1x120	12.9	3.4	29.0	30.0	1798	1043	420
1x150	14.2	3.4	30.3	31.3	2113	1168	440
1x185	16.2	3.4	32.5	33.5	2508	1343	470
1x240	18.2	3.4	34.7	35.7	3088	1577	500
1x300	21.2	3.4	37.9	38.9	3802	1913	540
1x400	23.4	3.4	40.3	41.3	4806	2286	580
1x500	27.3	3.4	44.4	45.4	5871	2722	630
1x630	30.5	3.4	47.8	48.8	7187	3220	680

THREE-CORES RE4H10R-6/10 kV - ARE4H10R-6/10 kV

nominal area conductor mm ²	conductor diameter d mm.	insulation thickness mm.	nominal overall diameter D mm.	maximum overall diameter mm.	approximate cable weight kg/km		minimum bending radius mm.
					Cu	Al	
3x 10	3.8	3.4	34.7	35.7	1088	902	500
3x 16	4.7	3.4	37.2	38.2	1981	1683	535
3x 25	5.9	3.4	37.7	38.7	2058	1893	542
3x 35	7.0	3.4	45.2	46.2	3106	2456	640
3x 50	8.2	3.4	47.9	48.9	3739	2795	680
3x 70	9.9	3.4	51.8	52.8	4614	3292	740
3x 95	11.5	3.4	55.5	56.5	5611	3817	790
3x120	12.9	3.4	58.9	59.9	6620	4353	840
3x150	14.2	3.4	61.9	62.9	7722	4887	880
3x185	16.2	3.4	66.4	67.4	9115	5620	940
3x240	18.2	3.4	71.1	72.1	11108	6574	1010

ARMoured THREE-CORES RE4H10ZR-6/10 kV - ARE4H10ZR-6/10 kV

nominal area conductor mm ²	conductor diameter d mm.	insulation thickness mm.	nominal overall diameter D mm.	maximum overall diameter mm.	approximate cable weight kg/km		minimum bending radius mm.
					Cu	Al	
3x 10	3.8	3.4	38.0	39.1	1580	1394	547
3x 16	4.7	3.4	39.8	40.9	2876	2578	573
3x 25	5.9	3.4	45.2	46.3	3529	3064	648
3x 35	7.0	3.4	50.4	51.4	4358	3707	720
3x 50	8.2	3.4	53.1	54.1	5079	4135	760
3x 70	9.9	3.4	57.0	58.0	6055	4732	810
3x 95	11.5	3.4	60.7	61.7	7151	5356	860
3x120	12.9	3.4	63.9	64.9	8222	5955	910
3x150	14.2	3.4	66.9	67.9	9416	6582	950
3x185	16.2	3.4	71.6	72.6	10979	7484	1020
3x240	18.2	3.4	76.1	77.1	13042	8508	1080

CONTINUOUS CURRENT RATINGS (ampere)

nominal area conductor	ground laying								air laying			
	R _t =100 °C cm/W				R _t =200 °C cm/W							
	mm ²	Cu ... Al	Cu .. Al	Cu ... Al	Cu .. Al	Cu ... Al	Cu .. Al	Cu ... Al	Cu .. Al	Cu ... Al	Cu .. Al	
1x 10	111	85	125	96	82	65	85	65	128	102	124	105
1x 16	134	103	140	108	100	78	102	79	151	121	145	116
1x 25	161	124	151	110	122	94	123	95	178	142	175	140
1x 35	194	151	182	140	149	113	141	108	209	152	195	156
1x 50	233	179	219	168	181	137	169	127	241	193	204	163
1x 70	283	223	268	213	217	166	203	156	320	243	285	205
1x 95	340	265	318	249	256	201	245	186	370	302	311	256
1x120	384	302	366	284	292	229	275	212	444	340	380	288
1x150	431	340	409	318	325	256	307	240	493	395	420	337
1x185	486	382	462	358	365	287	344	267	580	465	497	412
1x240	564	443	540	430	423	328	398	309	686	550	594	475
1x300	631	503	604	479	474	380	449	356	795	620	688	528
1x400	720	575	690	545	635	434	509	406	925	720	804	616
1x500	809	653	780	631	605	493	572	461	1001	820	864	700
1x630	905	739	879	719	674	554	648	527	1208	970	1065	954

CONTINUOUS CURRENT RATINGS (ampere)

nominal area conductor	ground laying				air laying	
	R _t =100 °C cm/W		R _t =200 °C cm/W			
	mm ²	Cu	Al	Cu	Al	Cu
3x 10	100	81	80	64	106	85
3x 16	122	100	97	78	126	101
3x 25	148	120	117	94	152	122
3x 35	181	151	143	114	185	146
3x 50	219	170	174	132	224	172
3x 70	270	213	212	167	279	214
3x 95	325	249	255	195	337	250
3x120	364	283	284	218	373	287
3x150	413	318	318	246	430	334
3x185	455	350	356	270	499	380
3x240	530	418	411	326	583	453

CONTINUOUS CURRENT RATINGS (ampere)

nominal area conductor	ground laying				air laying	
	R _t =100 °C cm/W		R _t =200 °C cm/W			
	mm ²	Cu	Al	Cu	Al	Cu
3x 10	97	79	77	62	103	83
3x 16	118	97	94	76	122	99
3x 25	143	116	113	91	147	119
3x 35	183	150	150	114	179	146
3x 50	215	171	174	128	220	168
3x 70	250	200	199	156	275	210
3x 95	273	243	258	193	315	245
3x120	352	281	281	211	373	278
3x150	402	272	318	209	419	329
3x185	450	345	457	262	484	380
3x240	519	410	410	316	550	450

SINGLE-CORE RE4H1R-8.7/15 kV - ARE4H1R-8.7/15 kV

nominal area conductor mm ²	conductor diameter d mm.	insulation thickness mm.	nominal overall diameter D mm.	maximum overall diameter mm.	approximate cable weight kg/km		minimum bending radius mm.
					Cu	Al	
1x 16	8.7	4.5	21.0	22.0	636	536	308
1x 25	5.9	4.5	23.0	24.0	748	599	336
1x 35	7.0	4.5	25.0	26.0	920	695	360
1x 50	8.2	4.5	26.5	27.3	1106	700	380
1x 70	9.9	4.5	28.2	29.2	1360	902	410
1x 95	11.5	4.5	29.8	30.8	1579	981	430
1x120	12.9	4.5	31.4	32.4	1936	1180	450
1x150	14.2	4.5	32.7	33.7	2254	1310	470
1x185	16.2	4.5	34.9	35.9	2660	1495	503
1x240	18.2	4.5	37.1	38.1	3246	1735	530
1x300	21.2	4.5	40.3	41.3	3920	2031	580
1x400	23.4	4.5	42.5	43.5	4904	2385	610
1x500	27.3	4.5	46.8	47.8	6000	2852	670
1x630	30.5	4.5	50.2	51.2	7321	3354	717

THREE-CORES RE4H10R-8.7/15 kV - ARE4H10R-8.7/15 kV

nominal area conductor mm ²	conductor diameter d mm.	insulation thickness mm.	nominal overall diameter D mm.	maximum overall diameter mm.	approximate cable weight kg/km		minimum bending radius mm.
					Cu	Al	
3x 16	4.7	4.5	39.9	41.0	1971	1673	574
3x 25	5.9	4.5	43.8	44.8	2347	1882	627
3x 35	7.0	4.5	50.0	51.0	3596	2946	710
3x 50	8.2	4.5	52.8	53.8	4254	3310	750
3x 70	9.9	4.5	56.7	57.7	5170	3848	810
3x 95	11.5	4.5	60.3	61.3	6195	4400	860
3x120	12.9	4.5	63.5	64.5	7212	4945	903
3x150	14.2	4.5	66.5	67.5	8338	5504	940
3x185	16.2	4.5	71.2	72.2	9812	6317	1010
3x240	18.2	4.5	75.6	76.6	11813	7279	1070

ARMOURED THREE-CORES RE4H10ZR-8.7/15 kV - ARE4H10ZR-8.7/15 kV

nominal area conductor mm ²	conductor diameter d mm.	insulation thickness mm.	nominal overall diameter D mm.	maximum overall diameter mm.	approximate cable weight kg/km		minimum bending radius mm.
					Cu	Al	
3x 16	4.7	4.5	45.5	46.6	3543	3245	652
3x 25	5.9	4.5	49.8	50.9	4220	3775	713
3x 35	7.0	4.5	55.1	56.1	4975	4324	780
3x 50	8.2	4.5	57.9	58.9	5723	4779	820
3x 70	9.9	4.5	61.8	62.8	6739	5416	880
3x 95	11.5	4.5	65.4	66.4	7906	6112	930
3x120	12.9	4.5	68.8	69.8	9000	6733	980
3x150	14.2	4.5	71.8	72.8	10224	7390	1020
3x185	16.2	4.5	76.3	77.3	11770	8275	1082
3x240	18.2	4.5	81.0	82.0	13957	9423	1140

CONTINUOUS CURRENT RATINGS (ampere)

nominal area conductor	ground laying								air laying			
	R _t =100 °C cm/W				R _t =200 °C cm/W							
	mm ²	Cu ... Al		Cu .. Al		Cu ... Al		Cu .. Al		Cu ... Al		Cu .. Al
1x 16	140	112	133	105	109	89	103	80	152	116	150	98
1x 25	165	132	156	122	128	105	121	94	179	136	176	124
1x 35	194	150	183	143	151	124	142	109	211	158	186	147
1x 50	228	178	217	168	177	138	168	129	250	193	190	183
1x 70	277	219	263	207	213	169	201	156	311	243	294	231
1x 95	333	261	315	246	254	199	239	186	382	298	333	280
1x120	381	299	363	282	293	227	277	213	439	320	383	327
1x150	427	332	406	314	326	253	308	236	505	382	462	363
1x185	484	378	461	357	368	286	349	268	560	420	550	418
1x240	556	437	530	415	420	330	399	311	694	543	621	494
1x300	630	495	602	469	473	373	449	351	796	615	711	574
1x400	709	574	679	545	527	431	508	407	905	702	832	689
1x500	803	638	775	619	601	478	582	453	1030	740	975	876
1x630	894	735	873	715	670	556	654	531	1500	950	1375	917

CONTINUOUS CURRENT RATINGS (ampere)

nominal area conductor	ground laying				air laying	
	R _t =100 °C cm/W		R _t =200 °C cm/W			
	mm ²	Cu	Al	Cu	Al	Cu
3x 16	133	106	97	76	136	109
3x 25	156	122	119	93	160	128
3x 35	184	145	145	112	190	150
3x 50	219	170	177	134	224	173
3x 70	259	205	208	160	273	215
3x 95	319	243	251	189	338	253
3x120	350	274	277	213	373	300
3x150	400	318	318	250	439	340
3x185	451	350	353	271	498	385
3x240	535	413	416	327	585	459

CONTINUOUS CURRENT RATINGS (ampere)

nominal area conductor	ground laying				air laying	
	R _t =100 °C cm/W		R _t =200 °C cm/W			
	mm ²	Cu	Al	Cu	Al	Cu
3x 16	129	103	94	74	132	106
3x 25	151	118	115	90	155	124
3x 35	180	144	147	124	181	146
3x 50	215	169	174	138	223	170
3x 70	253	200	203	162	270	215
3x 95	310	240	247	191	329	253
3x120	349	273	279	221	362	293
3x150	400	305	322	243	415	329
3x185	430	349	341	281	500	360
3x240	510	402	407	321	585	453

SINGLE-CORE RE4H1R-12/20 kV - ARE4H1R-12/20 kV

nominal area conductor mm ²	conductor diameter d mm.	insulation thickness mm.	nominal overall diameter D mm.	maximum overall diameter mm.	approximate cable weight kg/km		minimum bending radius mm.
					Cu	Al	
1x 25	6.0	5.5	26.0	27.0	892	737	380
1x 35	7.0	5.5	27.1	28.1	1021	804	390
1x 50	8.2	5.5	28.5	29.5	1216	902	410
1x 70	9.9	5.5	30.2	31.2	1464	1024	440
1x 95	11.5	5.5	32.0	33.0	1769	1171	460
1x120	12.9	5.5	33.4	34.4	2052	1297	480
1x150	14.2	5.5	34.9	35.9	2391	1447	500
1x185	16.2	5.5	37.1	38.1	2805	1640	530
1x240	18.2	5.5	39.1	40.1	3381	1870	560
1x300	21.2	5.5	42.3	43.3	4065	2176	600
1x400	23.4	5.5	44.7	45.7	5077	2553	640
1x500	27.3	5.5	48.8	49.8	6166	3017	700
1x630	30.5	5.5	52.4	53.4	7526	3559	750

THREE-CORES RE4H10R-12/20 kV - ARE4H10R-12/20 kV

nominal area conductor mm ²	conductor diameter d mm.	insulation thickness mm.	nominal overall diameter D mm.	maximum overall diameter mm.	approximate cable weight kg/km		minimum bending radius mm.
					Cu	Al	
3x 25	6.0	5.5	52.4	53.4	3611	3146	750
3x 35	7.0	5.5	54.5	55.5	4083	3432	770
3x 50	8.2	5.5	57.4	58.4	4771	3826	810
3x 70	9.9	5.5	61.2	62.2	5714	4392	870
3x 95	11.5	5.5	65.0	66.0	6810	5015	920
3x120	12.9	5.5	68.2	69.2	7847	5580	970
3x150	14.2	5.5	71.2	72.2	9000	6166	1010
3x185	16.2	5.5	75.6	76.6	10481	6986	1070
3x240	18.2	5.5	80.5	82.0	12700	8200	1140

ARMOURED THREE-CORES RE4H10ZR-12/20 kV - ARE4H10ZR-12/20 kV

nominal area conductor mm ²	conductor diameter d mm.	insulation thickness mm.	nominal overall diameter D mm.	maximum overall diameter mm.	approximate cable weight kg/km		minimum bending radius mm.
					Cu	Al	
3x 25	6.0	5.5	57.5	58.5	5045	4580	820
3x 35	7.0	5.5	59.8	60.8	5630	4979	850
3x 50	8.2	5.5	62.7	63.7	6381	5436	890
3x 70	9.9	5.5	66.5	67.5	7450	6128	940
3x 95	11.5	5.5	70.1	71.1	8614	6820	990
3x120	12.9	5.5	73.5	74.5	9780	7513	1040
3x150	14.2	5.5	76.3	77.3	10962	8128	1080
3x185	16.2	5.5	80.9	81.9	12611	9116	1140
3x240	18.2	5.5	85.5	86.5	14792	10258	1210

CONTINUOUS CURRENT RATINGS (ampere)

nominal area conductor	ground laying								air laying			
	R _t =100 °C cm/W				R _t =200 °C cm/W							
	mm ²	Cu ... Al		Cu ... Al		Cu ... Al		Cu ... Al		Cu ... Al		Cu ... Al
1x 25	160	125	154	125	126	101	118	96	173	130	154	119
1x 35	191	151	185	146	148	115	141	111	210	160	189	147
1x 50	227	175	220	169	176	135	169	131	250	193	224	169
1x 70	277	218	271	213	214	169	209	173	312	243	277	215
1x 95	333	258	319	248	255	196	247	190	383	301	340	265
1x120	380	297	364	284	290	225	280	218	437	342	386	300
1x150	426	330	414	319	324	251	316	243	500	393	441	343
1x185	482	375	466	364	366	285	356	275	572	458	506	404
1x240	557	429	540	416	421	323	410	312	675	520	600	462
1x300	620	491	604	478	466	370	455	360	773	615	589	539
1x400	715	565	695	551	538	427	523	416	890	703	798	620
1x500	785	639	770	623	585	473	576	466	1020	825	914	727
1x630	890	738	874	724	664	452	655	545	1182	948	1078	859

CONTINUOUS CURRENT RATINGS (ampere)

nominal area conductor	ground laying				air laying	
	R _t =100 °C cm/W		R _t =200 °C cm/W			
	mm ²	Cu	Al	Cu	Al	Cu
3x 25	153	124	130	104	155	125
3x 35	185	144	145	117	190	150
3x 50	216	172	172	138	222	175
3x 70	263	200	207	157	272	209
3x 95	319	243	254	190	330	253
3x120	354	274	279	216	375	300
3x150	405	310	323	244	430	339
3x185	445	349	351	275	500	383
3x240	529	413	414	325	590	454

CONTINUOUS CURRENT RATINGS (ampere)

nominal area conductor	ground laying				air laying	
	R _t =100 °C cm/W		R _t =200 °C cm/W			
	mm ²	Cu	Al	Cu	Al	Cu
3x 25	159	124	128	103	160	125
3x 35	180	143	142	114	184	150
3x 50	220	171	174	136	222	174
3x 70	263	202	207	159	270	215
3x 95	320	249	254	196	334	260
3x120	359	280	284	222	362	300
3x150	410	310	326	242	439	319
3x185	452	342	355	268	502	373
3x240	525	405	413	317	583	465

SINGLE-CORE RE4H1R-18/30 kV - ARE4H1R-18/30 kV

nominal area conductor mm ²	conductor diameter d mm.	insulation thickness mm.	nominal overall diameter D mm.	maximum overall diameter mm.	approximate cable weight kg/km		minimum bending radius mm.
					Cu	Al	
1x 35	7.0	8.0	32.3	33.3	1315	1098	466
1x 50	8.2	8.0	33.7	34.7	1512	1198	486
1x 70	9.9	8.0	35.6	36.6	1792	1350	512
1x 95	11.5	8.0	37.4	38.4	2114	1516	538
1x120	12.9	8.0	38.8	39.8	2406	1650	558
1x150	14.2	8.0	40.1	41.1	2742	1798	576
1x185	16.2	8.0	42.3	43.3	3176	2010	606
1x240	18.2	8.0	44.5	45.5	3788	2277	640
1x300	21.2	8.0	47.7	48.7	4502	2613	680
1x400	23.4	8.0	49.8	50.8	5534	3015	710
1x500	27.3	8.0	54.2	55.2	6662	3513	710
1x630	30.5	8.0	55.4	57.4	7820	3953	775

THREE-CORES RE4H10R-18/30 kV - ARE4H10R-18/30 kV

nominal area conductor mm ²	conductor diameter d mm.	insulation thickness mm.	nominal overall diameter D mm.	maximum overall diameter mm.	approximate cable weight kg/km		minimum bending radius mm.
					Cu	Al	
3x 35	7.0	8.0	61.4	62.8	4138	3482	873
3x 50	8.2	8.0	68.9	69.9	6273	5328	980
3x 70	9.9	8.0	72.8	73.8	7319	5997	1030
3x 95	11.5	8.0	76.5	77.5	8469	6674	1080
3x120	12.9	8.0	79.7	80.7	9575	7308	1130
3x150	14.2	8.0	82.7	83.7	10806	7972	1170
3x185	16.2	8.0	87.4	88.4	12420	8925	1240
3x240	18.2	8.0	91.9	92.9	14563	10030	1300

ARMoured THREE-CORES RE4H10ZR-v - ARE4H10ZR-18/30 kV

nominal area conductor mm ²	conductor diameter d mm.	insulation thickness mm.	nominal overall diameter D mm.	maximum overall diameter mm.	approximate cable weight kg/km		minimum bending radius mm.
					Cu	Al	
3x 35	7.0	8.0	67.3	69.3	6981	6330	956
3x 50	8.2	8.0	74.2	75.2	8212	7267	1050
3x 70	9.9	8.0	78.1	79.1	9360	8038	1100
3x 95	11.5	8.0	81.8	82.8	10610	8815	1160
3x120	12.9	8.0	85.0	86.0	11812	9545	1200
3x150	14.2	8.0	88.0	89.0	13136	10302	1240
3x185	16.2	8.0	92.7	93.7	14890	11395	1310
3x240	18.2	8.0	97.2	98.2	17166	12630	1370

CONTINUOUS CURRENT RATINGS (ampere)

nominal area conductor	ground laying								air laying			
	R _t =100 °C cm/W				R _t =200 °C cm/W							
	Cu ... Al		Cu .. Al		Cu ... Al		Cu .. Al		Cu ... Al		Cu .. Al	
mm ²												
1x 35	186	145	180	140	146	114	142	112	203	158	182	140
1x 50	227	179	220	173	178	139	173	137	250	195	225	174
1x 70	278	213	269	208	216	166	210	160	310	243	278	119
1x 95	330	258	318	247	255	198	247	191	380	300	341	268
1x120	374	291	363	281	287	221	279	214	430	341	386	304
1x150	425	330	414	319	327	253	318	245	470	380	418	349
1x185	487	379	473	361	375	285	365	276	573	443	513	394
1x240	552	429	438	417	423	326	411	317	670	525	604	471
1x300	635	489	622	474	488	372	477	361	763	603	691	539
1x400	705	553	692	540	537	419	527	409	882	698	801	627
1x500	803	631	788	618	608	477	599	467	1020	795	933	715
1x630	899	719	890	704	680	539	675	532	1152	906	1072	829

CONTINUOUS CURRENT RATINGS (ampere)

nominal area conductor	ground laying				air laying	
	R _t =100 °C cm/W		R _t =200 °C cm/W			
	Cu	Al	Cu	Al	Cu	Al
mm ²						
3x 35	184	142	150	116	180	139
3x 50	219	169	177	137	220	170
3x 70	260	205	206	167	268	215
3x 95	319	243	254	192	325	252
3x120	369	285	297	228	380	299
3x150	402	313	323	250	440	333
3x185	450	355	359	284	495	382
3x240	528	412	420	327	570	448

CONTINUOUS CURRENT RATINGS (ampere)

nominal area conductor	ground laying				air laying	
	R _t =100 °C cm/W		R _t =200 °C cm/W			
	Cu	Al	Cu	Al	Cu	Al
mm ²						
3x 35	178	138	147	114	175	135
3x 50	215	165	177	134	216	167
3x 70	255	203	202	162	262	210
3x 95	315	238	251	188	319	249
3x120	350	282	277	227	365	290
3x150	394	305	321	241	435	326
3x185	450	355	357	282	485	377
3x240	513	403	407	320	559	450

SINGLE-CORE RE4H1R-26/45 kV - ARE4H1R-26/45 kV

nominal area conductor mm ²	conductor diameter d mm.	insulation thickness mm.	nominal overall diameter D mm.	maximum overall diameter mm.	approximate cable weight kg/km		minimum bending radius mm.
					Cu	Al	
1x 70	9.9	10	37.7	40.0	1929	1510	560
1x 95	11.5	10	39.3	41.6	2224	1659	570
1x120	12.9	10	41.1	43.4	2558	1834	590
1x150	14.2	9	40.4	43.0	2729	1831	580
1x185	16.2	9	42.4	45.0	3140	2221	600
1x240	18.2	9	44.4	47.0	3681	2237	640
1x300	21.2	9	47.8	50.3	4410	2583	680
1x400	23.4	9	50.0	52.5	5427	2950	720
1x500	27.3	9	54.3	56.8	6441	3359	790
1x630	30.5	9	58.0	60.5	7879	4006	820

THREE-CORES RE4H10R-26/45 kV - ARE4H10R-26/45 kV

nominal area conductor mm ²	conductor diameter d mm.	insulation thickness mm.	nominal overall diameter D mm.	maximum overall diameter mm.	approximate cable weight kg/km		minimum bending radius mm.
					Cu	Al	
3x 70	9.9	10	81.0	84.0	8615	7393	1136
3x 95	11.5	10	84.8	87.8	9711	8152	1188
3x120	12.9	10	87.8	90.8	11012	8915	1230
3x150	14.2	9	88.3	91.3	11359	8798	1278
3x185	16.2	9	90.6	93.6	12694	9596	1310

ARMoured THREE-CORES RE4H10ZR-26/45 kV - ARE4H10ZR-26/45 kV

nominal area conductor mm ²	conductor diameter d mm.	insulation thickness mm.	nominal overall diameter D mm.	maximum overall diameter mm.	approximate cable weight kg/km		minimum bending radius mm.
					Cu	Al	
3x 70	9.9	10	87.0	90.0	10660	9425	1220
3x 95	11.5	10	90.3	93.3	11863	10187	1265
3x120	12.9	10	93.2	96.0	13242	11010	1344
3x150	14.2	9	94.6	99.0	15044	12254	1386

CONTINUOUS CURRENT RATINGS (ampere)

nominal area conductor	ground laying								air laying			
	R _t =100 °C cm/W				R _t =200 °C cm/W							
	mm ²	Cu ●●● Al		Cu ●● Al		Cu ●●● Al		Cu ●● Al		Cu ●●● Al		Cu ●● Al
1x 70	266	210	260	205	208	166	203	160	320	250	287	224
1x 95	320	253	310	248	250	199	244	192	386	304	349	275
1x120	358	284	340	279	283	225	280	215	47	350	401	316
1x150	408	320	397	312	310	245	306	241	505	401	453	360
1x185	455	363	448	355	353	278	348	271	580	460	520	409
1x240	530	420	520	414	408	320	404	314	680	537	615	485
1x300	591	474	583	465	449	360	444	352	772	668	704	553
1x400	678	540	670	530	507	402	505	398	886	715	815	645
1x500	750	612	745	602	569	455	565	450	1020	829	942	749
1x630	905	802	895	780	648	524	642	517	1185	971	1078	873

CONTINUOUS CURRENT RATINGS (ampere)

nominal area conductor	ground laying				air laying	
	R _t =100 °C cm/W		R _t =200 °C cm/W			
	mm ²	Cu	Al	Cu	Al	Cu
3x 70	247	194	199	159	261	205
3x 95	295	231	235	186	314	247
3x120	333	263	267	212	361	282
3x150	374	294	300	234	407	320
3x185	422	332	335	263	465	366

CONTINUOUS CURRENT RATINGS (ampere)

nominal area conductor	ground laying				air laying	
	R _t =100 °C cm/W		R _t =200 °C cm/W			
	mm ²	Cu	Al	Cu	Al	Cu
3x 70	242	190	199	157	256	200
3x 95	289	226	235	186	308	242
3x120	326	258	262	208	354	276
3x150	366	288	294	229	399	314

APPARENT ELECTRIC RESISTANCE OF THE CONDUCTOR (Ohm/Km) AT 50Hz AND AT 90°C

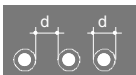

Single-core cables

nominal area conductor mm ²	copper conductors				aluminium conductors			
	3.6/6 kV	6/10 kV 8.7/15 kV	12/20 kV 15/20 kV 18/30 kV	26/45 kV	3.6/6 kV	6/10 kV 8.7/15 kV	12/20 kV 15/20 kV 18/30 kV	26/45 kV
10	2.310	2.310	–	–	3.780	–	–	–
16	1.455	1.455	–	–	2.392	2.392	–	–
25	0.937	0.936	0.936	–	1.512	1.512	1.512	–
35	0.674	0.676	0.676	–	1.094	1.094	1.094	–
50	0.500	0.499	0.499	–	0.818	0.818	0.818	–
70	0.345	0.345	0.345	0.345	0.566	0.566	0.566	0.566
95	0.249	0.248	0.248	0.248	0.409	0.409	0.409	0.409
120	0.198	0.197	0.197	0.197	0.323	0.323	0.323	0.323
150	0.161	0.161	0.161	0.161	0.263	0.263	0.263	0.263
185	0.127	0.127	0.127	0.127	0.210	0.210	0.210	0.210
240	0.0984	0.0983	0.0982	0.0981	0.160	0.160	0.161	0.161
300	0.0789	0.0787	0.0788	0.0786	0.130	0.130	0.130	0.129
400	0.0624	0.0624	0.0623	0.0622	0.102	0.102	0.102	0.102
500	0.0496	0.0495	0.0494	0.0491	0.0812	0.0810	0.0812	0.0805
630	0.0395	0.0394	0.0393	0.0391	0.0649	0.0646	0.0649	0.0645



Single-core cables

nominal area conductor mm ²	all voltages	
	copper cond.	aluminium cond.
10	1.310	3.780
16	1.455	2.392
25	0.936	1.512
35	0.675	1.094
50	0.499	0.818
70	0.345	0.566
95	0.250	0.409
120	0.197	0.322
150	0.162	0.265
185	0.130	0.211
240	0.0995	0.163
300	0.0805	0.133
400	0.0644	0.106
500	0.0521	0.0853
630	0.0429	0.0704



Three-cores cables

nominal area conductor mm ²	all voltages	
	copper cond.	aluminium cond.
10	2.346	3.845
16	1.479	2.431
25	0.937	1.542
35	0.675	1.112
50	0.499	0.818
70	0.344	0.565
95	0.250	0.410
120	0.198	0.325
150	0.163	0.264
185	0.130	0.213
240	0.100	0.164
300	0.0815	0.134
400	0.0658	0.108
500	0.0536	0.0879

CAPACITY VALUES AT 50 Hz (µF/Km)

nominal area conductor mm ²	3.6/6 kV	6/10 kV	8.7/15 kV	12/20 kV	18/30 kV	26/45 kV
10	0.175	0.17	0.150	–	–	–
16	0.185	0.175	0.155	–	–	–
25	0.19	0.19	0.16	0.13	–	–
35	0.21	0.21	0.19	0.15	0.12	–
50	0.25	0.25	0.20	0.17	0.13	–
70	0.27	0.27	0.21	0.20	0.15	0.12
95	0.30	0.30	0.26	0.22	0.17	0.14
120	0.34	0.34	0.28	0.24	0.19	0.16
150	0.37	0.37	0.30	0.26	0.20	0.18
185	0.39	0.39	0.33	0.28	0.21	0.20
240	0.42	0.42	0.36	0.30	0.23	0.22
300	0.48	0.48	0.40	0.33	0.26	0.24
400	0.53	0.53	0.44	0.36	0.27	0.26
500	0.60	0.60	0.48	0.41	0.30	0.28
630	0.69	0.69	0.55	0.46	0.34	0.31

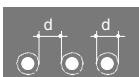

Single-core cables (average value)

nominal area conductor mm ²	3.6/6 kV	6/10 kV	8.7/15 kV	12/20 kV	18/30 kV	26/45 kV
10	0.13	0.15	0.16	—	—	—
16	0.15	0.16	0.18	—	—	—
25	0.18	0.19	0.20	0.21	—	—
35	0.18	0.19	0.19	0.20	0.21	—
50	0.17	0.18	0.19	0.19	0.20	—
70	0.17	0.17	0.18	0.19	0.20	0.21
95	0.16	0.17	0.17	0.18	0.19	0.20
120	0.16	0.16	0.17	0.18	0.18	0.19
150	0.16	0.16	0.17	0.17	0.18	0.19
185	0.15	0.16	0.16	0.17	0.18	0.18
240	0.15	0.16	0.16	0.16	0.17	0.18
300	0.15	0.15	0.16	0.16	0.17	0.17
400	0.15	0.15	0.15	0.16	0.16	0.17
500	0.14	0.15	0.15	0.15	0.16	0.17
630	0.14	0.15	0.15	0.15	0.16	0.16



Single-core cables

nominal area conductor mm ²	3.6/6 kV	6/10 kV	8.7/15 kV	12/20 kV	18/30 kV	26/45 kV
10	0.15	0.16	0.16	—	—	—
16	0.14	0.15	0.15	—	—	—
25	0.13	0.14	0.14	0.15	—	—
35	0.12	0.13	0.14	0.14	0.16	—
50	0.11	0.12	0.13	0.13	0.15	—
70	0.11	0.12	0.12	0.13	0.14	0.15
95	0.10	0.11	0.12	0.12	0.13	0.14
120	0.10	0.11	0.11	0.12	0.13	0.14
150	0.098	0.10	0.11	0.11	0.12	0.13
185	0.094	0.10	0.11	0.11	0.12	0.12
240	0.091	0.097	0.10	0.11	0.11	0.12
300	0.089	0.095	0.098	0.10	0.11	0.12
400	0.087	0.091	0.096	0.098	0.11	0.11
500	0.083	0.089	0.092	0.096	0.10	0.11
630	0.082	0.087	0.090	0.093	0.098	0.10



Three-cores cables

nominal area conductor mm ²	3.6/6 kV	6/10 kV	8.7/15 kV	12/20 kV	18/30 kV	26/45 kV
10	0.13	0.14	0.5	—	—	—
16	0.12	0.13	0.14	—	—	—
25	0.11	0.12	0.13	0.14	—	—
35	0.10	0.11	0.12	0.13	0.14	—
50	0.096	0.11	0.12	0.12	0.13	—
70	0.092	0.10	0.11	0.11	0.13	0.14
95	0.088	0.097	0.10	0.10	0.12	0.13
120	0.086	0.094	0.10	0.10	0.12	0.13
150	0.084	0.091	0.097	0.10	0.11	0.12
185	0.082	0.087	0.094	0.097	0.11	0.11
240	0.079	0.085	0.090	0.094	0.10	—
300	0.077	0.084	0.088	0.092	0.10	—
400	0.075	0.082	0.086	—	—	—
500	0.074	0.078	—	—	—	—

AMBIENT TEMPERATURE DIFFERENT FROM STANDARD CONDITIONS

Ambient temperature °C	15	20	25	30	35	40	45	50	55	60	65
Ground laying cables	1.04	1.00	0.96	0.92	0.88	0.84	0.80	–	–	–	–
Air Cables*	–	1.09	1.09	1.00	0.95	0.90	0.85	0.79	0.74	0.67	0.60

* Not exposed to direct sunlight

THREE-CORES CABLES (OR SINGLE-CORE CABLES ENCLOSED IN TREFOIL) GROUNDED LAYING

Number of cables or trefoil-set (horizontally)		2	3	4	6
	7 cm	0.84	0.74	0.67	0.60
Space between cables or trefoil-sets	25 cm	0.86	0.78	0.74	0.69

THREE-CORES CABLES (OR SINGLE-CORE CABLES ENCLOSED IN TREFOIL) GROUNDED PIPE LAYING

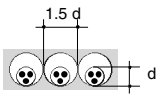

Number of cables (horizontally)	1	2	3
	0.82	0.69	0.61

THREE-CORES CABLES AIR LAYING

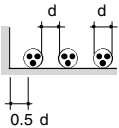

Number of cables (horizontally)	1	2	3	6
	0.95	0.90	0.88	0.85

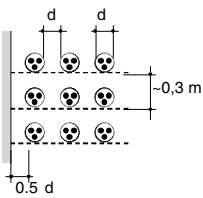

Number of cables (horizontally)	1	2	3	6	
Number of layers (vertically)	1	1.00	0.98	0.96	0.93
	2	1.00	0.95	0.93	0.90
	3	1.00	0.94	0.90	0.87

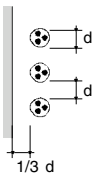

Number of cables (vertically)	1	2	3	6
	1.00	0.93	0.90	0.87

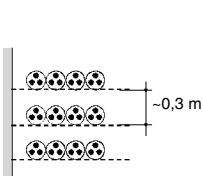

Number of cables (horizontally)	1	2	3	6	
Number of layers (vertically)	1	0.95	0.84	0.80	0.75
	2	0.95	0.80	0.76	0.71
	3	0.95	0.78	0.74	0.70



Number of cables (vertically)	1	2	3	6
	0.95	0.78	0.73	0.68

SINGLE-CORE CABLES TREFOIL AIR LAYING

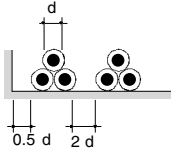

Number of trefoil sets (horizontally)	1	2	3	4
	0.95	0.90	0.88	0.87

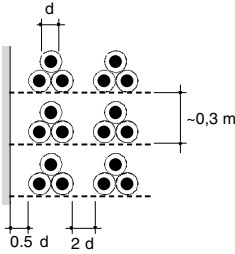

Number of trefoil sets (horizontally)	1	2	3	
Number of layers (vertically)	1	1.00	0.98	0.96
	2	1.00	0.95	0.93
	3	1.00	0.94	0.90

SINGLE-CORE CABLES AIR LAYING HORIZONTALLY AND VERTICALLY SPACED OUT

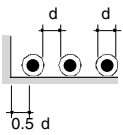

Number of trefoil sets (horizontally)	1	2	4
	0.92	0.89	0.97

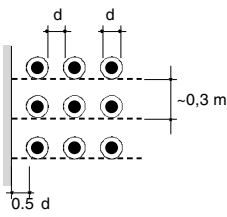

Number of trefoil sets (horizontally)	1	2	
Number of layers (vertically)	1	1.00	0.97
	2	0.97	0.94
	3	0.96	0.93

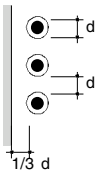

Number of trefoil sets (vertically)	1	2
	0.94	0.91

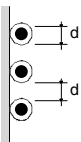

Number of trefoil sets (vertically)	1	2
	0.89	0.86

PHASE LAY-OUT FOR SINGLE-CORE CABLES CONNECTED IN PARALLEL TO PROVIDE CORRECT CURRENT SPLITTING

Trefoil laying cables

Number of trefoil sets in the same layer*	2	3	4
	T RS T SR	T RS T SR T RS	T RS T SR T RS T SR

Horizontally or vertically spaced-out cables

Number of trefoil sets in the same layer*	2	4
	RST TSR	RST TSR RST TSR

*When cables are installed on several layers their lay-out must be repeated for each layer.

SHORT CIRCUIT RATING

The maximum short circuit current allowed for short period of time (a few seconds) for copper or aluminium conductors can be calculated by the following formula:

$$I_{cc} = \frac{K \cdot S}{t} \text{ (A)}$$

where:
I_{cc} = short circuit current (A)
K = factor of the conducting material which obtained from the difference between starting and final temperature of short circuit;
 K copper = 143
 K aluminium = 92
S = area conductor (mm²)
t = duration of short circuit (sec.)

The following table reports the values in KA of the current calculated for the starting temperature of 90°C and for the duration of 1 second.

Area conductor mm ²	Copper	Aluminium
10	1.4	0.9
16	2.3	1.5
25	3.6	2.3
35	5.0	3.2
50	7.1	4.6
70	10	6.4
95	14	8.7
120	17	11
150	21	14
185	26	17
240	34	22
300	43	28
400	57	37
500	72	46
630	90	58

K factor (final temperature = 250°C)

Material Conductor	Starting temperature		
	50	70	90
copper	165	154	143
aluminium	107	100	92

To calculate the current allowed in the screen you can use the same formula indicated above for the conductor with the factor K = 180°C.

VOLTAGE DROP

The voltage drop can be calculated by the following formula for connections in alternating current:

$$\Delta V = K \cdot L \cdot I (R \cdot \cos\phi + X \cdot \sin\phi)$$

where:
ΔV = voltage drop (V)
K = 1,73 for three-phase system
K = 2 for single-phase system
L = connection length (km)
I = current rating (A)
R = conductor resistance at using temperature (Ohm/km)
X = phase reactance (Ohm/km)
cosφ = power factor

For direct current connection cosφ = 1

COMPARISON BETWEEN RATED VOLTAGES AND INSULATION RATE

Insulation rate	Nominal voltage kV U ₀ /U	Maximum voltage kV U _m
8	1.8/3	3.6
11	3.6/6	7.2
17	6/10	12
24	8.7/15	17.5
32	12/20	24
47	18/30	36
67	26/45	52

U₀ = relates to the nominal tension between a conductor and earth
U = relates to the nominal tension between the conductors of the cable
U_m = greatest tension which the cable is suitable

The final tests to which the **Medium Voltage** cables are subjected are in compliance with IEC 60502-2 standard.

Routine tests

- Electrical resistance of conductor
- Partial discharge on cables having cores with conductors screens and insulation screens
- Voltage test

Sample tests

- Conductor examination
- Check of dimensions
- Voltage test for cable of rated voltage above 3,6/6 (7.2) kV
- Hot set test for EPR, HEPR and XLPE insulations and elastomeric sheaths

Electrical type tests

- Partial discharge test
- Bending test
- Tan δ measurement
- Heating cycle test
- Impulse test
- Voltage test

Non-electrical type tests

- Thickness of insulation
- Thickness of non-metallic sheaths
- Mechanical properties of insulation before and after ageing
- Mechanical properties of non-metallic sheaths before and after ageing
- Additional ageing test of completed cables
- Loss of mass test on PVC sheaths of type ST₂
- Pressure test at high temperature on insulation and non-metallic sheaths
- Test on PVC insulation and sheaths at low temperatures
- Test for resistance of PVC insulation and sheaths to cracking (heat shock test)
- Ozone resistance test for EPR and HEPR insulations
- Hot set test for EPR, HEPR and XLPE insulation and elastomeric sheaths
- Oil immersion test for elastomeric sheaths
- Water absorption test on insulation
- Flame retardance test
- Carbon black content of black PE oversheath
- Shrinkage test for XLPE insulation
- Thermal stability test for PVC insulation
- Determination of hardness of HEPR insulation
- Determination of elastic modulus of HEPR insulation
- Shrinkage test for PE oversheaths
- Strippability test for insulation screen
- Water penetration test

Electrical tests after installation

Tests after installation are made, if required, when the installation of the cable and its accessories has been completed. They are for new installations only.

- d.c. voltage equal to 4 U₀ shall be applied for 15 min.

As an alternative, and by agreement between the contractor and purchaser, an a.c. voltage test at power frequency, in accordance with indicated below:

- test for 5 min. with the phase-to-phase voltage of the system applied between the conductor and the metallic screen;
- test for 24 hours with the normal operating voltage of the system.

Insulation rated voltage U ₀ kV	Electrical tests after installation in c.c. for 15' kV
3.6	14.4
6.0	24
8.7	34.8
12	48
18	72
26	104

STORAGE AND HANDLING

The drums storage and movement shall be carried out with crane or forklift truck. It is not allowed to drop drums from the truck to the floor. All cables during transport and handling can be damaged so we suggest to verify before and during installation procedure any possible damage to avoid heavy problems during cable working life. For the benefit of the workers involved in electrical work is absolutely necessary to observe some safety rules normally indicated on the local still in force standards.

Do not remove staves and cable end caps until the cable will be laid down. If you cut a piece of cable leaving the rest in a open stock put on again ends protections. Unwind and rewind cables as shown in the pictures. In case of transferring from one drum to another remember the minimum bending cable radius and consequently the barrel drum diameter.

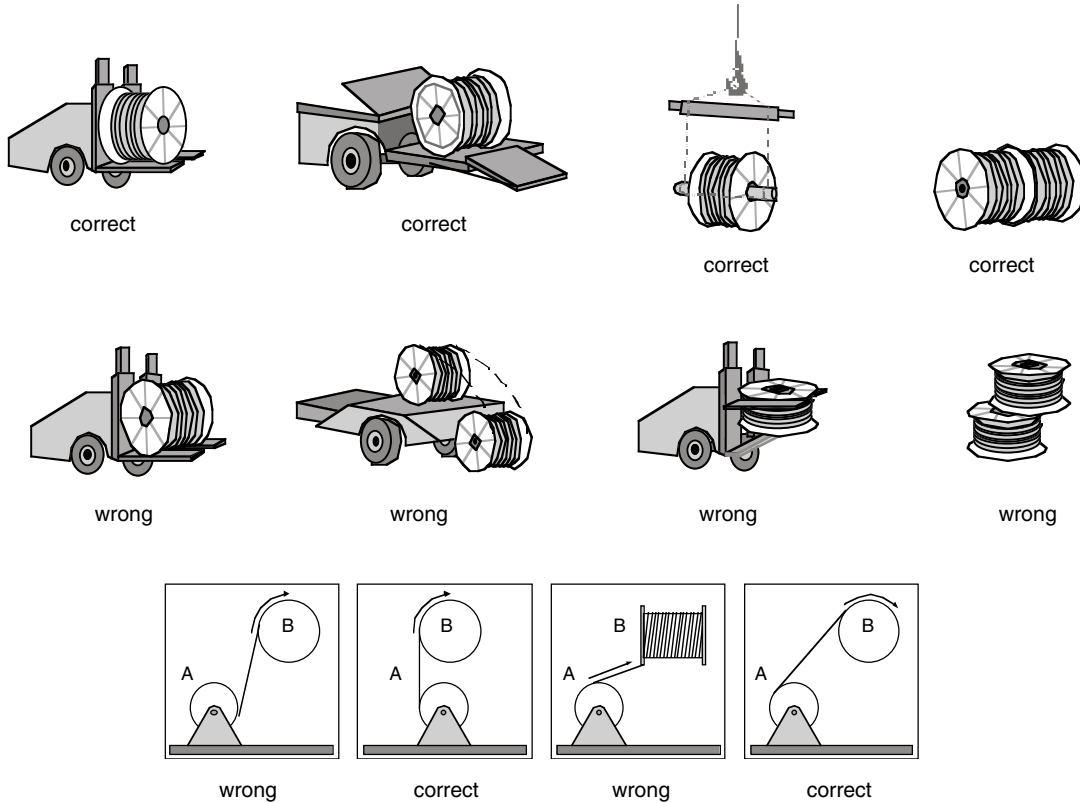

INSTALLATION

We summarize some rules to be observed during the installation of MV cables for fixed laying. In order to provide easy operations we suggest do not work at cable temperature below than 5°C. Cables bending radius are indicated in Range and Dimensions tables and they must be to value carefully. For unarmoured cables and in order to pull cable inside pipes or trench it is advisable to apply the pull force on the conductors being careful do not exceed 5 kg/mm² of total area for copper cables and 3 kg/mm² for aluminium cables.

Example:

copper cable	1 x 240 mm ² :	max pull force kg	1200
aluminium cable	1 x 240 mm ² :	max pull force kg	720
copper cable	3 x 240 mm ² :	max pull force kg	3600
aluminium cable	3 x 240 mm ² :	max pull force kg	2160

For steel cable armour the strain rope will be applied to the armour while the pull force by steel braid is advisable only for limited efforts.

If there are curves along the lay route must be placed a sufficient conveyers, for example at the entrance of pipes, suitable to keep the cable in the right direction line in order to avoid to exceed the maximum pulling load allowed.

Concerning overhead cables any strain will be charged on the supporting rope for installation operations and during working time.

Besides data reported in this booklet is always important to consider the effects of thermal dissipation. All installations in parallel trefoil must be realized with maximum care in order to aim the most balanced charge distribution on the cables connected to the same phase. Therefore please consider the following information:

- all cables must have the same metal conductors
- all cables must have the same length and section
- the bundle cables must be made-up following R, S and T phases system as indicated on page 25
- the cables must be properly spaced
- right and balanced connections to the cables terminals

How to draw the cable

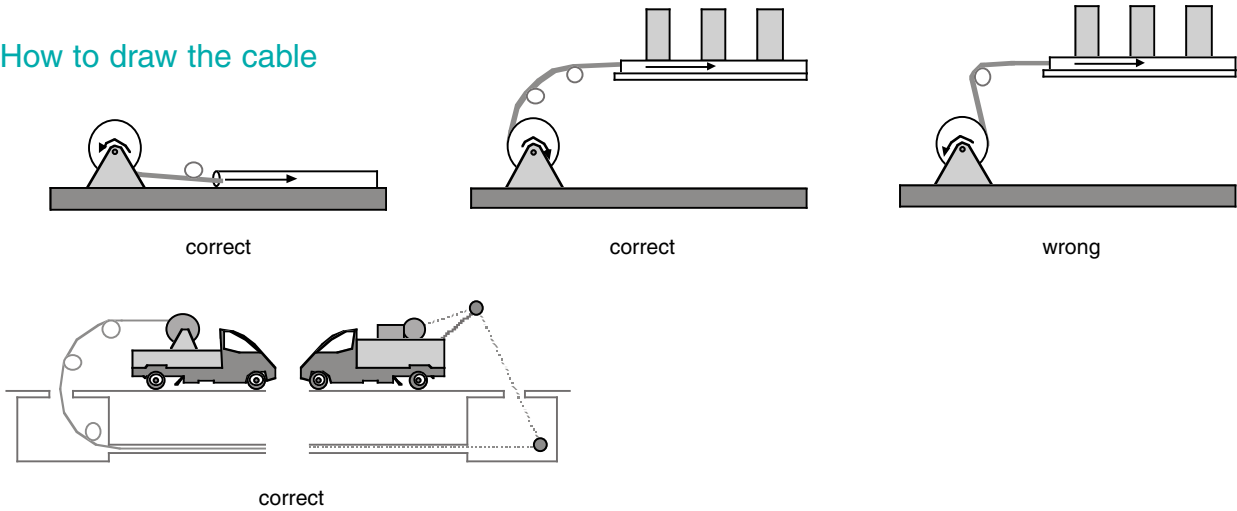

PACKAGING

DRUMS CAPACITY (meters)

Cable diameter mm	DRUM TYPE											
	BL60	BL70	BL80	BL90	BL100	BL120	BL140	BL160	BL180	BL200	BL220	BL250
11	446	769	994	130	2041	3441	5248	5991	8320	11896	13901	17758
14	275	475	614	3	1260	2124	3240	3698	5137	7344	8582	10963
17	187	322	416	805	855	1441	2197	2508	3484	4981	5820	7435
20	135	233	301	546	617	1041	1588	1812	2517	3599	4205	5372
23	102	176	227	394	467	787	1200	1370	1903	2721	3180	4062
26	80	138	178	298	365	616	939	1072	1489	2129	2488	3179
29		111	143	233	294	495	755	862	1197	1712	2000	2555
34		80	104	188	202	365	549	627	871	1245	1455	1859
40			75	136	154	260	397	453	629	900	1051	1343
46				99	117	197	300	343	476	680	795	1015
52					91	154	235	268	372	532	622	795
58						124	189	215	299	428	500	639
64						102	155	177	246	351	411	525
70							130	148	205	294	343	439
76							110	125	174	249	291	372
82							94	108	150	214	250	320
88								94	130	186	217	277
94									114	163	190	243
100									101	144	168	215
105									91	131	153	195
110										119	139	178

HOW TO SELECT THE DRUM

Example:

1 - kind cable ARE4H1R-12/20 kV 1x240 mm² see page 16
 overall cable diameter mm 39.1 a round figure mm 40
 minimum bending radius mm 560
 cable quantity mt 500

2 - **determination of drum barrel diameter** = mm 560 x 2 = 1120 mm consequently qualified drums are BL180/200/220/250. ■

3 - **outcome** = following above practice the more convenient drum able to contain mt 500 is BL 180 ■

DRUMS DIMENSION

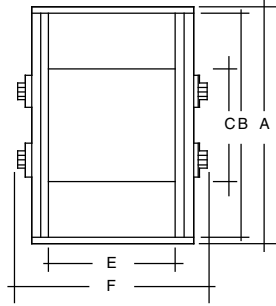
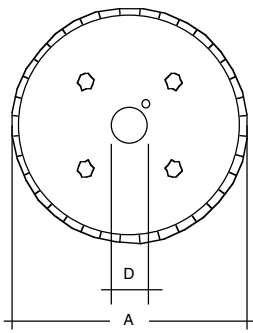

A - Flange diameter including circumference batten
 B - Flange diameter without circumference batten
 C - Inner barrel diameter
 D - Axis hole
 E - Inner width
 F - External width

DRUM TYPE	A mm	B mm	C mm	D mm	E mm	F mm	Drum weight Kg	Batten weight Kg	Global volume m ³
BL60	690	630	315	80	315	435	15	11	0.17
BL70	770	710	355	80	400	515	20	16	0.25
BL80	860	800	400	80	450	575	25	21	0.34
BL90	960	900	450	80	450	575	36	23	0.42
BL100	1.060	1.000	500	80	560	685	44	30	0.62
BL120	1.310	1.250	630	80	630	760	77	42	1.10
BL140	1.460	1.400	710	80	750	920	113	56	1.60
BL160	1.660	1.600	900	80	900	1.070	182	75	2.40
BL180	1.860	1.800	1.120	80	1.120	1.320	319	106	3.70
BL200	2.060	2.000	1.250	125	1.120	1.320	387	121	4.50
BL220	2.300	2.240	1.400	125	1.120	1.320	478	135	5.60
BL250	2.510	2.450	1.500	125	1.120	1.320	560	148	6.50

NOTE

The data belong to the standard wooden drums daily in force in all Tratos Cavi facilities. Nevertheless for uncommon cable lengths there are available very large wooden and metallic drums. In this cases transport restrictions have to be considered like special law-loading trailers and permits from traffic authorities in accordance with local regulations.

- A.C.** - Alternating current in which the charge-flow periodically reverses
- Accessories** - Components necessary to cables network connection
- Aluminium conductor** - An aluminium wire or group of wires
- Aluminium screen** - Usually a longitudinal smooth or corrugated aluminium tape overlapped and thermosealed
- AWG** - America Wire Gauge
- Bending radius** - Minimum bending radius a cable can be bent without permanent damage
- BS** - British Standard (UK)
- Cable tray** - A channel system used to hold and support power cable
- Cable pipe** - A pipe used to contain power cable
- Capacitance** - The value of the capacity of a dielectric material between two conductors
- CEI** - Comitato Elettrotecnico Italiano
- Compacted conductor** - Ensure regular conductor diameter avoiding stress to insulation layer
- Conductor losses** - Power losses due to the resistance of conductors
- Conductor screen** - An extrusion layer direct on the cable conductor of a semi-conducting material to provide regular distribution of electrical stress
- Copper conductor** - A copper wire or group of wires
- Copper screen** - Overlapping spiral-wound copper tapes or copper wires to coil up
- Dielectric** - Generally a non metallic material with high resistivity
- Dielectric constant** - The relation between the charge by a condenser with dielectric material and vacuum
- D.C.** - Direct current
- Dielectric losses** - Power losses due to the conductance of dielectric materials
- Dielectric strength** - Maximum voltage gradient that a material withstand
- Embossing code** - Raised cable code on the outersheath
- Electrical resistance** - The resistance of the materials to the flow of current (Ohm/km)
- Electrical metal screen** - A metal shield against external fields, need to equalize electric fields
- Electromagnetic compatibility** - The capability of different electrical system to coexist without interferences
- Electrical gradient** - The sheare of dielectrical strength express in kV/mm
- Filler** - Mass of material to fill laying cores interstices in order to provide an approximate round shape cable, through extrusion or by different elements assembled together cores
- Frequency** - The number of cycles (hertz) of an alternating current in one second
- HEPR** - High ethylene propylene rubber
- IEC** - International Electrotechnical Committee
- Insulation** - Dielectric layer
- Insulation screen** - An extrusion layer direct on the cable insulation of a semi-conducting material which uniform radial stress distribution across insulation
- Jacket** - The outer protective covering of a cable
- Joints** - Accessory suitable to joint two cables
- Laying depth** - Installation depth trench
- Lug** - Accessory suitable to connect a cable conductor to the network
- Metallic armour** - Additional mechanical cable protection usually covered by a plastic layer
- M1** - LSOH low smoke and zero halogen
- MT** - Medium tension
- MV** - Medium voltage
- NF** - Norme Française (F)
- Phase lay-out** - System to provide a correct current splitting
- PE** - Polyethylene
- Plain conductor** - Mean a conductor of only one metal
- Print code** - Ink print cable code in the outersheath
- PVC** - Polyvinyl chloride
- Reactance** - The opposition to the flow of alternating current by inductance or capacitance
- Resistivity** - A conductor electric resistance
- Semiconductor** - A material with lower electrical resistance than a dielectric material
- Sheath** - The outer protective covering of a cable
- Short circuit current** - Breakdown due temperature rise
- Single core** - One phase cable
- System** - Network
- Terminations** - Accessory suitable to connect a cable to the network
- Trefoil** - Lay-out of three single cable
- Three cores** - Three phases cables
- Uo kV** - Nominal tension between any insulated conductor to earth
- U kV** - Nominal tension between two insulated conductor of the cable
- Um kV** - Maximum tension which the cable is suitable
- UNE** - Unificación de Normas Españolas (E)
- VDE** - Verband der Elektrotechnik (D)
- Voltage drop** - Reduced voltage in the circuit
- XLPE** - Cross-linked polyethylene