

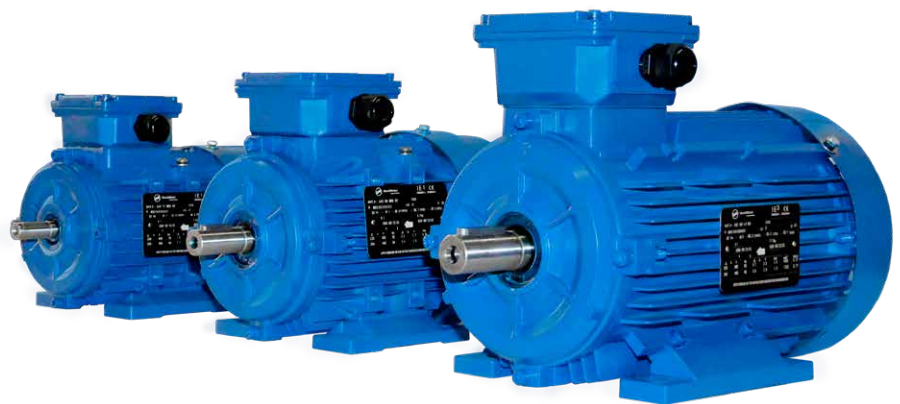

MarelliMotori
Powering the future®



APF MOTOR SERIES

Technical Catalogue - Low Voltage

INDEX

02	ABOUT MARELLI MOTORI
03	THREE-PHASE SQUIRREL CAGE INDUCTION MOTORS
03	MOTOR APPLICATIONS
04	STANDARD CONFIGURATION
04	RATING PLATES
04	STANDARDS
05	EUROPEAN DIRECTIVES
05	ENERGY SAVING
06	EFFICIENCY CLASSES
07	TECHNICAL CHARACTERISTICS
07	PROTECTIVE TREATMENTS
08	MOUNTING AND POSITIONS
09	IC CODE - COOLING (IEC 60034-6)
10	MATERIALS
13	BEARINGS
15	BEARINGS FOR STANDARD MOTORS
17	AXIAL FORCES - HORIZONTAL MOUNTING
18	AXIAL FORCES - VERTICAL MOUNTING
20	RADIAL FORCES - HORIZONTAL MOUNTING
21	MOTORS FOR HIGH RADIAL LOADS - BEARINGS
22	TERMINAL BOX AND CABLE ENTRY

23	TERMINAL BOXES - DIMENSIONS
26	AUXILIARY TERMINAL BOXES
26	GROUNDING
27	CONDENSATION DRAINAGE
27	ANTICONDENSATION HEATERS
27	THERMAL PROTECTIONS
28	CONNECTION DIAGRAMS
30	STARTING
30	STARTING RESPONSE
30	TYPE OF STARTING
33	MOTORS FOR VARIABLE SPEED APPLICATIONS
34	MOTORS FOR FORCED VENTILATION
34	INSTALLATION \leq 1000 M A.S.L.
34	DERATINGS
35	EFFICIENCY AND POWER FACTOR
36	TOLERANCES FOR ELECTROMECHANICAL CHARACTERISTICS
36	VOLTAGE AND FREQUENCY
37	OPTIONS AND CONFIGURATIONS
39	MECHANICAL TOLERANCES
39	TAPPED HOLES IN THE SHAFT EXTENSION



40 DATA TABLE | 50Hz

41	A1C - 400 V - 50 Hz - ALUMINIUM - IE1
44	B1C - 400 V - 50 Hz - CAST IRON - IE1
49	A2C - 400 V - 50 Hz - ALUMINIUM - IE2
52	B2C - 400 V - 50 Hz - CAST IRON - IE2
56	A3C - 400 V - 50 Hz - ALUMINIUM - IE3
58	B3C - 400 V - 50 Hz - CAST IRON - IE3

62 DIMENSIONS

63	A1C - A2C DIMENSIONS - ALUMINIUM
65	A3C DIMENSIONS - ALUMINIUM
67	B1C - B2C DIMENSIONS - CAST IRON
67	B1C - B2C DIMENSIONS - CAST IRON
70	B3C DIMENSIONS - CAST IRON

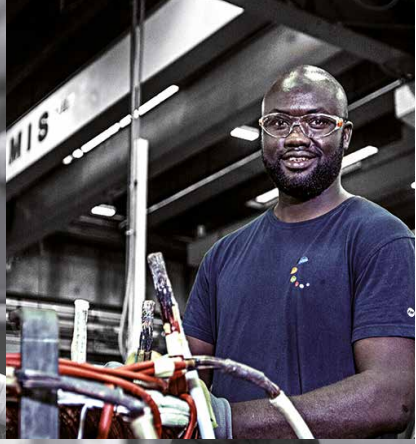



ABOUT MARELLI MOTORI

Marelli Motori is a leading manufacturer of electric motors and generators. Founded in northern Italy in 1891, the company enjoys worldwide brand recognition in the marine, oil & gas, power generation, co-generation, hydro, and other industrial sectors.

Marelli Motori employs around 630 people and operates an extensive manufacturing facility in Italy with own subsidiaries in the United States, Germany, South Africa and Malaysia and has an extended sales, distribution, and service network across four continents, supplying its technologically advanced products in more than 120 countries.

In 2019, Marelli Motori was acquired by Langley Holdings plc, the British engineering and industrial group.

MARELLI MOTORI OPERATES IN SIX CORE INDUSTRIES



Power generation

Generators up to 14000 kVA

Cogeneration

Generators up to 14000 kVA

Hydropower

Asynchronous generators up to 3000 kW

Synchronous generators up to 11000 kVA



Oil & gas

Generators up to 14000 kVA

Motors up to 1600 kW



Industrial motors

Motors up to 10000 kW

Marine

Generators up to 12500 kVA

Motors up to 10000 kW

THREE-PHASE SQUIRREL CAGE INDUCTION MOTORS

MOTOR APPLICATIONS

- **A1C, A2C, A3C motors are made of aluminium frame, available from 63 to 180 frame size.**
- **B1C, B2C, B3C motors are made of cast iron frame, available from 63 to 355 frame size.**

Our motor industrial applications include:

- water pumping and treatments;
- air treatment and conditioning;
- food and beverage processing industry;
- pulp and paper;
- metal;
- manufacturing processes;
- lifting;
- compressors;
- ventilation.

Design flexibility

Our flexibility even reaches final assembly, a point at which customers are still able to adapt a design to meet the requirements of their specific application.

Once in the field, our products can be equipped with a range of retrofit devices enabling the continuous refinement and upgrading of machine performance.

Reliable performance

All our products undergo extensively testing in our in-house laboratories to ensure the correct evaluation of electrical and mechanical performances in any working conditions.

Serviceability

Our motors have been specifically designed for ease-of-maintenance, offering quick access to key components to facilitate MRO activities and reduce servicing costs.

All our products have a friendly user-interface which, together with a global service network available worldwide, ensures best-in-class performance and high ROI.

Safety first

All Marelli Motori manufacturing sites have a H&S Management System in compliance with BS OHSAS 18001:2007.

Low carbon footprint

Marelli Motori products are designed to deliver maximum performance, high energy efficiency, and to achieve the lowest carbon footprint possible.

For example, the energy recovery process in place during test room activities enables us to reduce our impact on the environment and mitigate global warming.

Social responsibility

Marelli Motori's approach to social responsibility is based upon minimising our impact on the environment and preserving the world's natural resources.

A key part of this approach is engagement with all of our stakeholders, including our supply chain and customers, partnering with universities for research and development, and supporting local communities with charity activities.

STANDARD CONFIGURATION

RATING PLATES

All motors in standard configuration are supplied with stainless steel identification plates.

Motors subject to efficiency classification “IE” have the correspondent band label on the nameplate. All motors supplied with regreasing systems have regreasing data shown on the main nameplate.

MarelliMotori Powering the future®		IE3 IEC 60034-1		CE	ⓧ		
MOT.3~	A3C 160 M4	COD. 12002243	S.F. 1,15	kg 89			
N° 200700506	I.Cl. F/B	S 1	IP 55				
6309-Z-C3		6309-Z-C3					
Δ V	λ	Hz	Δ A	λ	kW	min ⁻¹	cos. φ
220	380	50	37,2	21,5	11,00	1470	0,85
230	400	50	35,5	20,4	11,00	1470	0,85
240	415	50	34,1	19,7	11,00	1470	0,85
	440	60	21,4	12,65	1764		0,85
	460	60	20,4	12,65	1764		0,85
50 Hz - IE3 -		4/4 - 91,4%		3/4 - 91,8%		2/4 - 91,1%	
Imported by Marelli Motori - CONTACT POINT: P.O. BOX 60 - ARZIGNANO1 - VI - ITALY							

MarelliMotori Powering the future®		IE3 IEC 60034-1		CE	ⓧ		
MOT.3~	A3C 160 M4	COD. 12002251	S.F. 1,15	kg 89			
N° 200700506	I.Cl. F/B	S 1	IP 55				
6309-Z-C3		6309-Z-C3					
Δ V	λ	Hz	Δ A	λ	kW	min ⁻¹	cos. φ
380	660	50	21,5	12,4	11,00	1470	0,85
400	690	50	20,4	11,8	11,00	1470	0,85
415		50	19,7		11,00	1470	0,85
440		60	21,4		12,65	1764	0,85
460		60	20,4		12,65	1764	0,85
50 Hz - IE3 -		4/4 - 91,4%		3/4 - 91,8%		2/4 - 91,1%	
Imported by Marelli Motori - CONTACT POINT: P.O. BOX 60 - ARZIGNANO1 - VI - ITALY							

STANDARDS

Title	IEC	GB
Rating and performance	60034 - 1	GB755
Standard methods for determining losses and efficiency from tests	60034 - 2 - 1	GB/T 1032
Classification of degrees of protection (IP code)	60034 - 5	GB/T 4942.1
Methods of cooling (IC code)	60034 - 6	GB/T 1993
Classification of type of construction and mounting arrangement and terminal box position (IM code)	60034 - 7	GB/T 997
Terminal markings and direction of rotation	60034 - 8	GB 1971
Noise limits	60034 - 9	GB/T10069
Thermal protection	60034 - 11	GB/T 13002
Starting performance of single-speed three-phase cage induction motors	60034 - 12	GB/T 21210
Mechanical vibration of certain machines with shaft heights 56 mm and higher. Measurement, evaluation and limits of vibration severity	60034 - 14	GB 10068
Efficiency classes of single-speed, three-phase, cage-induction (IE code)	60034 - 30 - 1	GB 3289.1
Standard voltages	60038	GB 156
Dimensions and outputs series for electrical machines. Part1: Frame numbers 56 to 400 flange numbers 55 to 1080	60072 - 1	GB/T 4772.1

EUROPEAN DIRECTIVES

Marelli Motori motors fully comply with the following directives.

Electromagnetic Compatibility (EMC)	2014/30/EU
Low Voltage Directive (LVD)	2014/35/EU
Machinery Directive	2006/42/EC

CE mark declaration of conformity

All low voltage products described in this catalogue are marked CE and are in conformity with the requirements of the applicable Directive. With references to the Machinery Directive, the above mentioned product is to be considered as a component.

ENERGY SAVING

European standards for motors efficiency

In order to harmonise the energy consumption regulations concerning the reduction of CO₂ emissions and the impact of industrial operations on the environment, the International Electrotechnical Commission (IEC) has established the IEC 60034-30-1 standard, which defines energy efficiency classes for single-speed, three-phase, 50 Hz and 60 Hz induction motors.

In that regard, the European Community (EC) has passed the Commission Regulation (EU) N° 4/2014, which amend the previous Commission Regulation (EC) N° 640/2009. Together these regulations are also referred to as EU MEPS (European Minimum Energy Performance Standard), and set mandatory minimum efficiency levels for electric motors introduced into the European market.

Electric motors account for about 70% of the electricity consumed by industry. The potential cost saving of high-efficiency systems is estimated at 20% to 30%, and one of the major factors in such cost-effective improvement is the use of energy-efficient motors.

The IEC 60034-30-1 standard is part of an effort to unify motor testing standards, efficiency requirements and product labelling requirements so high-efficiency products can be easily recognised worldwide.

To show compliance with these new efficiency standards, motors must be tested in accordance with the new IEC 60034-2-1 testing standard. The motor efficiency class and nominal motor efficiency must be stated on the motor nameplate and given in product documentation and motor catalogues.

Scope

Commission Regulation (EU) No 1781/2019 covers single speed, single and three-phase, 50 Hz and 60 Hz induction motors with:

- 2, 4, 6 and 8 poles;
- rated output from 0,12 kW to 1000 kW;
- rated voltage up to 1000 V;
- continuous duty.

The regulation shall not apply to:

- motors specified to operate wholly immersed in a liquid;
- motors completely integrated into a product (for example gears, pumps, fans or compressors) of which the energy performance cannot be tested independently from the product;
- brake motors, when the brake can not be dismantled or separately fed;
- motors specified to operate exclusively:
 1. at altitudes exceeding 4000 m above sea-level;
 2. where ambient air temperatures exceed 60°C;
 3. in maximum operating temperature above 400°C;
 4. where ambient air temperatures are less than -30°C for any type of motor or less than 0°C for a motor with water cooling;
 5. where water coolant temperature is less than 0°C or exceeds 32°C;
 6. in potentially explosive atmospheres (ATEX) as defined in Directive L 2014/34/EU.

Deadlines

From July 1st 2021, motors installed in one of the countries of the European Union must comply with Energy Efficiency Class:

- IE2 as minimum from 0,12kW to 0,75kW;
- IE3 as minimum from 0,75kW to 1000 kW.

EFFICIENCY CLASSES

The new IEC 60034-30-1 standard defines worldwide the following efficiency classes of single-speed three-phase and cage-induction motors in the 0,12-1000 kW power range. Reference values at 50 Hz are shown in the following table.

Power kW	IE1 Standard				IE2 High				IE3 Premium				iE4 Super Premium			
	2p	4p	6p	8p	2p	4p	6p	8p	2p	4p	6p	8p	2p	4p	6p	8p
0,12	45,0	50,0	38,3	31,0	53,6	59,1	50,6	39,8	60,8	64,8	57,7	50,7	66,5	69,8	64,9	62,3
0,18	52,8	57,0	45,5	38,0	60,4	64,7	56,6	45,9	65,9	69,9	63,9	58,7	70,8	74,7	70,1	67,2
0,20	54,6	58,5	47,6	39,7	61,9	65,9	58,2	47,4	67,2	71,1	65,4	60,6	71,9	75,8	71,4	68,4
0,25	58,2	61,5	52,1	43,4	64,8	68,5	61,6	50,6	69,7	73,5	68,6	64,1	74,3	77,9	74,1	70,8
0,37	63,9	66,0	59,7	49,7	69,5	72,7	67,6	56,1	73,8	77,3	73,5	69,3	78,1	81,1	78,0	74,3
0,40	64,9	66,8	61,1	50,9	70,4	73,5	68,8	57,2	74,6	78,0	74,4	70,1	78,9	81,7	78,7	74,9
0,55	69,0	70,0	65,8	56,1	74,1	77,1	73,1	61,7	77,8	80,8	77,2	73,0	81,5	83,9	80,9	77,0
0,75	72,1	72,1	70,0	61,2	77,4	79,6	75,9	66,2	80,7	82,5	78,9	75,0	83,5	85,7	82,7	78,4
1,1	75,0	75,0	72,9	66,5	79,6	81,4	78,1	70,8	82,7	84,1	81,0	77,7	85,2	87,2	84,5	80,8
1,5	77,2	77,2	75,2	70,2	81,3	82,8	79,8	74,1	84,2	85,3	82,5	79,7	86,5	88,2	85,9	82,6
2,2	79,7	79,7	77,7	74,2	83,2	84,3	81,8	77,6	85,9	86,7	84,3	81,9	88,0	89,5	87,4	84,5
3	81,5	81,5	79,7	77,0	84,6	85,5	83,3	80,0	87,1	87,7	85,6	83,5	89,1	90,4	88,6	85,9
4	83,1	83,1	81,4	79,2	85,8	86,6	84,6	81,9	88,1	88,6	86,8	84,8	90,0	91,1	89,5	87,1
5,5	84,7	84,7	93,1	81,4	87,0	87,7	86,0	83,8	89,2	89,6	88,0	86,2	90,9	91,9	90,5	88,3
7,5	86,0	86,0	84,7	83,1	88,1	88,7	87,2	85,3	90,1	90,4	89,1	87,3	91,7	92,6	91,3	89,3
11	87,6	87,6	86,4	85,0	89,4	89,8	88,7	86,9	91,2	91,4	90,3	88,6	92,6	93,3	92,3	90,4
15	88,7	88,7	87,7	86,2	90,3	90,6	89,7	88,0	91,9	92,1	91,2	89,6	93,3	93,9	92,9	91,2
18,5	89,3	89,3	88,6	86,9	90,9	91,2	90,4	88,6	92,4	92,6	91,7	90,1	93,7	94,2	93,4	91,7
22	89,9	89,9	89,2	87,4	91,3	91,6	90,9	89,1	92,7	93,0	92,2	90,6	94,0	94,5	93,7	92,1
30	90,7	90,7	90,2	88,3	92,0	92,3	91,7	89,8	93,3	93,6	92,9	91,3	94,5	94,9	94,2	92,7
37	91,2	91,2	90,8	88,8	92,5	92,7	92,2	90,3	93,7	93,9	93,3	91,8	94,8	95,2	94,5	93,1
45	91,7	91,7	91,4	89,2	92,9	93,1	92,7	90,7	94,0	94,2	93,7	92,2	95,0	95,4	94,8	93,4
55	92,1	92,1	91,9	89,7	93,2	93,5	93,1	91,0	94,3	94,6	94,1	92,5	95,3	95,7	95,1	93,7
75	92,7	92,7	92,6	90,3	93,8	94,0	93,7	91,6	94,7	95,0	94,6	93,1	95,6	96,0	95,4	94,2
90	93,0	93,0	92,9	90,7	94,1	94,2	94,0	91,9	95,0	95,2	94,9	93,4	95,8	96,1	95,6	94,4
110	93,3	93,3	93,3	91,1	94,3	94,5	94,3	92,3	95,2	95,4	95,1	93,7	96,0	96,3	95,8	94,7
132	93,5	93,5	93,5	91,5	94,6	94,7	94,6	92,6	95,4	95,6	95,4	94,0	96,2	96,4	96,0	94,9
160	93,8	93,8	93,8	91,9	94,8	94,9	94,8	93,0	95,6	95,8	95,6	94,3	96,3	96,6	96,2	95,1
200	94,0	94,0	94,0	92,5	95,0	95,1	95,0	93,5	95,8	96,0	95,8	94,6	96,5	96,7	96,3	95,4
250	94,0	94,0	94,0	92,5	95,0	95,1	95,0	93,5	95,8	96,0	95,8	94,6	96,5	96,7	96,5	95,4
315	94,0	94,0	94,0	92,5	95,0	95,1	95,0	93,5	95,8	96,0	95,8	94,6	96,5	96,7	96,6	95,4
355	94,0	94,0	94,0	92,5	95,0	95,1	95,0	93,5	95,8	96,0	95,8	94,6	96,5	96,7	96,6	95,4
400	94,0	94,0	94,0	92,5	95,0	95,1	95,0	93,5	95,8	96,0	95,8	94,6	96,5	96,7	96,6	95,4
450	94,0	94,0	94,0	92,5	95,0	95,1	95,0	93,5	95,8	96,0	95,8	94,6	96,5	96,7	96,6	95,4
≥500	94,0	94,0	94,0	92,5	95,0	95,1	95,0	93,5	95,8	96,0	95,8	94,6	96,5	96,7	96,6	95,4

TECHNICAL CHARACTERISTICS

Continuous duty S1

The type of duty is indicated by the symbols S1-S9 as defined in the IEC 60034-1 standard.

Duty type S1 refers to operation at a constant load maintained for sufficient time to allow the machine to reach thermal equilibrium.

Insulation class F

Class F insulation systems are used in Marelli Motori motors.

This is the most common industry requirement today. The class F insulation system allows a temperature rise of 105K, measured by the resistance variation method, and a maximum temperature value of 155°C. Insulation class H allows a temperature rise of 125K from an ambient temperature of 40°C and a maximum temperature value of 180°C. Insulation class H can be provided on request.

Degree of Protection IP55

The motors in standard configuration have IP55 degree of protection, where:

5 (first number in code): ingress of dust is not totally prevented but dust does not enter in sufficient quantity to interfere with satisfactory operation of the machine.

5 (second number in code): the machine has sufficient water protection that a nozzle sprayed from any direction has no harmful effect.

Temperature rise compatible with class B

Class B temperature rise allows a maximum winding temperature rise of 80K under normal running conditions (rated voltage, frequency and load), with maximum ambient temperature of 40°C and altitude up to 1,000 m above sea level (a.s.l.).

Installation ≤ 1000 m a.s.l.:

The performance of standard motors is considered at a maximum altitude of 1000 m a.s.l. with motors running in continuous duty, at nominal voltage, frequency and a maximum ambient temperature of 40°C.

The table displayed on page 34 gives the performance variations of the motors when used in different conditions.

PROTECTIVE TREATMENTS

External surfaces

The surface treatment categorisation of motors is based on the ISO 12944 standard.

ISO 12994-5 divides paint system durability into three categories: low (L), medium (M), and high (H).

Low durability corresponds to a lifetime of 2-5 years, medium to 5-15 years, and high durability to over 15 years. The durability range is not a guaranteed lifetime. Its purpose is to help the owner of the motor plan for appropriate maintenance intervals. More frequent maintenance may be required because of fading, chalking, contamination, wear and tear, or for other reasons.

The painting treatment of motors in standard configuration is in accordance to C3 medium corrosivity category which is suitable for indoor atmospheres (heated buildings with a clean atmosphere).

Internal surfaces

Tropicalisation treatment is recommended to prevent corrosion when motor works under severe environmental conditions and/or when the humidity level exceeds 95%.

MOUNTING AND POSITIONS

Motors are supplied according to type of construction. B3, B5, B35, B14, B34 and V1 motors are compatible with mounting arrangements shown in the table below and defined in the IEC-60034-7 standard.

Code I (Simplified)							
IEC 60034-7			Frame size				
Code I	Code II	Mounting	63÷160	180	200÷250	280÷315	355
IM B3	IM 1001	(1)	●	●	●	●	●
IM B35	IM 2001	(1) (2)	●	●	●	●	●
IM B34	IM 2101	(1) (3)	●	●			
IM B5	IM 3001	(2)	●	●	●	●	X
IM B6	IM 1051	(1)	●	X	X		
IM B7	IM 1061	(1)	●	X	X		
IM B8	IM 1071	(1)	●	X	X		
IM B14	IM 3601	(3)	●	●			

Code II (Complete)							
IEC 60034-7			Frame size				
Code I	Code II	Mounting	63÷160	180	200÷250	280÷315	355
IM V1	IM 3011	(2)	●	●	●	●	●
IM V15	IM 2011	(1) (2)	●	●	●	●	●
IM V3	IM 3031	(2)	●	X	X		
IM V36	IM 2031	(1) (2)	●	X	X		
IM V5	IM 1011	(1)	●	X	X		
IM V6	IM 1031	(1)	●	X	X		
IM V18	IM 3611	(3)	●				
IM V19	IM 3631	(3)	●				

Key

- Standard
- X Contact Marelli Motori

marellimotori.com

- (1) Motors with feet
- (2) Flanged motor: unthreaded through holes
- (3) Flanged motor: threaded dead holes

IC CODE - COOLING (IEC 60034-6)

The designation of cooling method is given by IC (International Cooling) code, according to the IEC 60034-6 standard.

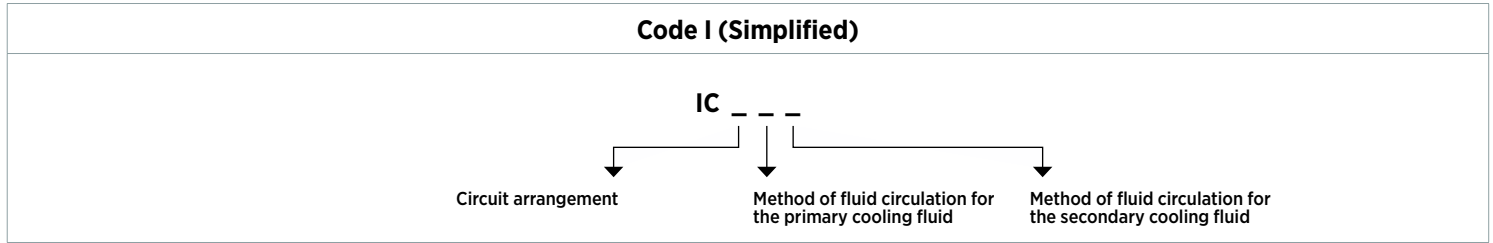

Typical fluids

A	Air
W	Water

Typical circuit arrangements

0	Free circulation
4	Machine surface - cooled
6	Heat exchanger machine mounted (using the motor surrounding coolant)
7	Heat exchanger built in the machine (not using the motor surrounding coolant)
8	Heat exchanger machine mounted (not using the motor surrounding coolant)

Typical methods of circulation

0	Free circulation
1	Self circulation
6	Circulation with independent device

Example of designation - IC 411

IC	Code IC
4	Circuit arrangement
A	Primary fluid
1	Method of circulation for primary fluid
A	Secondary fluid
1	Method of circulation for secondary fluid

Motors in standard configuration have an IC 411 cooling system.
Motors can be supplied with IC 416 or IC 418 cooling systems on request.

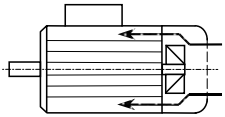
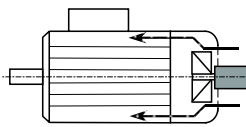
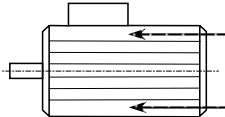
IC 411	Self ventilating motor. Enclosed machine. Externally finned. External shaft-mounted fan.	
IC 416	Motor with assisted ventilation. Enclosed machine. Externally finned. Independent external fan mounted inside the fan cover.	
IC 418	Motor with external ventilation. Enclosed machine. Externally finned. Ventilation provided by air flowing from the driven system.	

MATERIALS

The mechanical components used in Marelli Motori motors are made of the materials shown in the table below.

Components	Frame size				
	A_C 63-180	B_C 63-315	B1C/B2C 355	B3C 355	B_C 355K
Housing	aluminium				cast iron
Endshields	D-End	aluminium			cast iron
	N-End	aluminium			cast iron
Fan	FRPP*	FRPP*	aluminium	FRPP*	steel
Fan cover			steel		
Terminal box	aluminium				cast iron
Terminal box cover	aluminium				cast iron

FRPP* Flame Retardant Polypropilene

Balancing and vibration grades

The motors are subject to dynamic balancing with a half key applied to the shaft extension in accordance with the IEC 60034-14 standard and to vibration grade A in standard execution. The following table indicates the limits of vibration magnitude in displacement, velocity and acceleration (r.m.s.) for shaft height H.

Large vibrations may occur in motors installed on site due to several factors such as unsuitable foundations or reactions caused by the driven application. In such cases checks should also be carried out on each element of the installation.

Motors can also be supplied with grade B on request.

Vibration grade	Mounting	63 ≤ H ≤ 132			160 ≤ H ≤ 280			H > 280		
		Displac. [µm]	Speed [mm/s]	Acc. [m/s ²]	Displac. [µm]	Speed [mm/s]	Acc. [m/s ²]	Displac. [µm]	Speed [mm/s]	Acc. [m/s ²]
A reduced	Free	25	1,6	2,5	35	2,2	3,5	45	2,8	4,4
	Rigid	21	1,3	2,0	29	1,8	2,8	37	2,3	3,6
B special	Free	11	0,7	1,1	18	1,1	1,7	29	1,8	2,8
	Rigid	-*	-*	-*	14	0,9	1,4	24	1,5	2,4

*Rigid mounting is not considered acceptable for machines with shaft heights less than 132 mm.

The instrumentation can have a measurement tolerance of ± 10%. The free suspension condition is achieved by suspending the machine on a spring or by mounting the machine on an elastic support (springs, rubber, etc.).

Coupling

Elastic or flexible couplings have to be correctly carried out in order to avoid the transmission of axial and/or radial loads to the motor shaft and bearings. The permissible radial loads with regards to belt coupling are indicated in the table on page 21.

Noise

Medium values of A-sound pressure level (LpA) and A-sound power level (LwA) are measured at a one metre distance in accordance with the ISO/R 1680 standard. Sound levels are measured at no-load and a tolerance of 3 dB(A) shall be applied. Values of sound pressure increase by approximately a 4 dB(A) at 60Hz. To reduce noise levels, a special fan can be fitted to motors on request. (Contact Marelli Motori to check requested derating and admissible outputs.)

A1C	A - sound pressure level (LpA) - [dB(A)]			
Type	LpA at 50Hz, 1m distance			
	2 poles	4 poles	6 poles	8 poles
63	55	52	-	-
71	57	53	52	-
80	59	56	54	52
90	70	58	55	55
100	74	62	56	55
112	75	64	62	62
132	77	66	65	63
160	79	68	65	64
180	79	68	68	68

A2C	A - sound pressure level (LpA) - [dB(A)]			
Type	LpA at 50Hz, 1m distance			
	2 poles	4 poles	6 poles	8 poles
63	55	52	-	-
71	57	53	52	-
80	59	56	54	52
90	70	58	55	55
100	74	62	56	56
112	75	64	62	62
132	77	66	65	63
160	79	68	65	64
180	79	68	68	68

A3C	A - sound pressure level (LpA) - [dB(A)]			
Type	LpA at 50Hz, 1m distance			
	2 poles	4 poles	6 poles	8 poles
80	58	56	-	-
90	59	57	54	-
100	62	60	55	55
112	64	62	61	61
132	68	64	64	62
160	72	65	65	63
180	74	67	67	67

" - " Machine not available at this size

B1C	A - sound pressure level (LpA) - [dB(A)]					
Type	LpA at 50Hz, 1m distance					
	2 poles	4 poles	6 poles	8 poles	10 poles	12 poles
63	55	52	-	-	-	-
71	57	53	52	-	-	-
80	59	56	54	52	-	-
90	70	58	55	55	-	-
100	74	62	56	55	-	-
112	75	64	62	62	-	-
132	77	66	65	63	-	-
160	79	68	65	64	-	-
180	79	68	68	68	-	-
200	81	74	72	71	-	-
225	82	75	72	71	-	-
250	82	76	74	72	-	-
280	86	80	77	74	-	-
315	90	84	80	79	77	75
355	91	86	85	83	81	78
355K	92	87	86	84	-	-

B2C	A - sound pressure level (LpA) - [dB(A)]			
Type	LpA at 50Hz, 1m distance			
	2 poles	4 poles	6 poles	8 poles
63	55	52	-	-
71	57	53	52	-
80	59	56	54	52
90	70	58	55	55
100	74	62	56	56
112	75	64	62	62
132	77	66	65	63
160	79	68	65	64
180	79	68	68	68
200	81	74	72	71
225	82	75	72	71
250	82	76	74	72
280	86	80	77	74
315	90	84	80	79
355	91	86	85	83
355K	92	87	86	84

" - " Machine not available at this size

B3C	A - sound pressure level (LpA) - [dB(A)]			
Type	LpA at 50Hz, 1m distance			
	2 poles	4 poles	6 poles	8 poles
80	58	56	-	-
90	59	57	54	-
100	62	60	55	55
112	64	62	61	61
132	68	64	64	62
160	72	65	65	63
180	74	67	67	67
200	74	71	70	70
225	77	73	71	70
250	77	74	72	71
280	80	77	75	73
315	83	80	78	77
355	84	83	83	79
355K	84	84	84	82

" - " Machine not available at this size

BEARINGS

General data

According to the ISO 281/1 standard, the theoretical lifetime of bearings (L10h) used in standard horizontal construction motors and not subject to external forces (radial and/or axial) is in excess of 50000 hours. On request, L10h can be in excess of 100000 hours.

The motors from 63 to 132 frame size have floating bearings. The motors from 160 frame size have locating bearings on the D-End side and floating bearings on the N-End side. On request special bearings are designed where high radial and axial forces are applied.

The lifetime of bearings determined by multiple factors and specifically by:

- the lifetime of the grease (mainly on double screen bearings);
- the environmental conditions and working temperature;
- the external loads and vibrations.

The motors ≤ 132 frame size have double screen pre-lubricated ball bearings.

The motors from 160 to 180 frame size have single screen pre-lubricated ball bearings.

The correspondent grease life under normal operating conditions for a motor with a horizontal shaft, at 50Hz and maximum ambient temperature of 40°C is:

- 10000 hours in continuous duty for 2-pole motors;
- 20000 hours in continuous duty for ≥4-pole motors.

Motors from 160 frame size and above have regreasable bearings and relative exhausted grease drainage. For initial charge of standard motor bearings, grease with mineral oil as basic oil, lithium soap as thickener, and of National Lubricating Grease Institute (NLGI) consistency grade 2, is used.

Motors for unfavourable operating conditions can be lubricated with special grease.

The name plate indicates the type of grease, the quantity and the relubrication intervals.

For standard motors, relubrication data applies for neutral ambient conditions, at the rated speed, with almost vibration-free running and without any additional axial or radial load.

Immediately after regreasing the bearing temperature rises (10-15°C) for a while, and then drops to normal values after the grease has been uniformly distributed and the excess grease has been displaced from the bearing.

An excessive quantity of grease causes the bearing to self-heat.

The relubrication intervals refer to an average temperature about 70°C. With higher temperatures, the lubrication interval must be shortened. For vertical mounting (motors frame from 160 to 355) the values must be halved.

Frame size	Relubrication intervals [h]										
	3600 min ⁻¹	3000 min ⁻¹	1800 min ⁻¹	1500 min ⁻¹	1200 min ⁻¹	1000 min ⁻¹	900 min ⁻¹	750 min ⁻¹	720 min ⁻¹	600 min ⁻¹	500 min ⁻¹
160	2000	2400	5400	6500	6900	8200	8400	8600	9000	-	-
180	2000	2400	5400	6500	6900	8200	8400	8600	9000	-	-
200	1500	1800	5000	6000	6500	7800	8000	8200	8600	-	-
225	1500	1800	5000	6000	6500	7800	8000	8200	8600	-	-
250	1100	1300	4500	5400	6300	7500	7700	7900	8300	-	-
280	1000	1200	4500	5400	6300	7500	7700	7900	8300	-	-
315	1000	1200	3800	4500	6000	7200	7400	7600	8000	8300	8300
355	1000	1200	3200	3800	5500	6600	6800	7000	7400	7600	7600

Grease quantity																
Frame size	160		180		200		225		250		280		315		355	
Poles	2	≥4	2	≥4	2	≥4	2	≥4	2	≥4	2	≥4	2	≥4	2	≥4
Grease quantity (g)	20	20	25	25	25	25	30	30	35	35	35	35	50	50	60	60

BEARINGS FOR STANDARD MOTORS

Type	Frame size	Poles	Horizontal			Vertical		
			D-End	N-End	ID Bearing Assembly Diagram	D-End	N-End	ID Bearing Assembly Diagram
A_C B_C	63	ALL	6201-ZZ-C3		1	6201-ZZ-C3		1
	71	ALL	6202-ZZ-C3		1	6202-ZZ-C3		1
A_C B_C	80	ALL	6204-ZZ-C3		1	6204-ZZ-C3		1
	90	ALL	6205-ZZ-C3		1	6205-ZZ-C3		1
	100	ALL	6206-ZZ-C3		1	6206-ZZ-C3		1
	112	ALL	6306-ZZ-C3		1	6306-ZZ-C3		1
	132	ALL	6308-ZZ-C3		1	6308-ZZ-C3		1
A_C	160	ALL	6309-Z-C3		2	6309-Z-C3		2
	180	ALL	6311-Z-C3		2	6311-Z-C3		2
B_C	160	ALL	6309-C3		3	6309-C3		3
	180	ALL	6311-C3		3	6311-C3		3
	200	ALL	6312-C3		3	6312-C3		3
	225	ALL	6313-C3		3	6313-C3		3
	250	ALL	6314-C3		3	6314-C3	7314 B	5
	280	2	6314-C3		3	6314-C3	7314 B	5
	280	4-8	6317-C3		3	6317-C3	7317 B	5
	315	2	6316-C3		4	6316-C3	7316-B	6
	315	4-8	6319-C3		4	6319-C3	7319-B	6
	355 M-LB	2	6319-C3		4	6319-C3	7319-B	7
	355 M-LB	4-8	6322-C3		4	6322-C3	7322-B	7
	355 KB-KD	2	6319-C3		4	6319-C3	7319-B	7
	355 KB-KD	4-8	6322-C3		4	6322-C3	7322-B	7

Axial rotor position		
Frame size	Horizontal arrangement	Vertical arrangement
160 - 225 M	Locked at D-End	
250 M - 355	Locked at D-End	Locked at N-End

Re-greasing systems are supplied on all motors from frame size 160 and above.

Drawings: Bearing assembly diagrams of standard motors

1

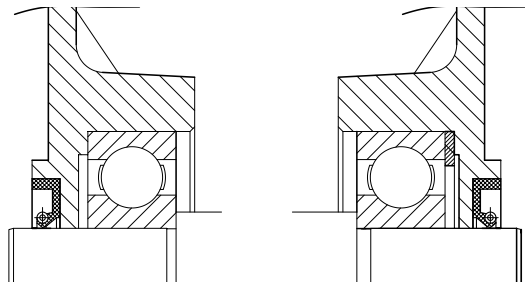

D-End

N-End

2

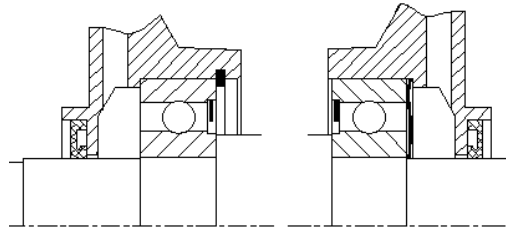

D-End

N-End

3

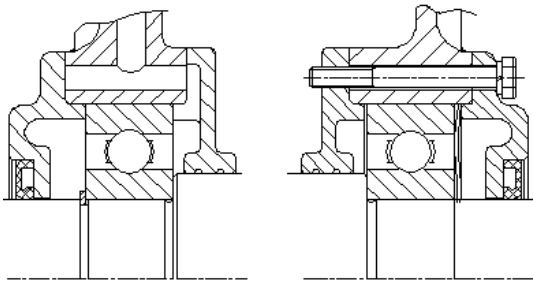

D-End

N-End

4

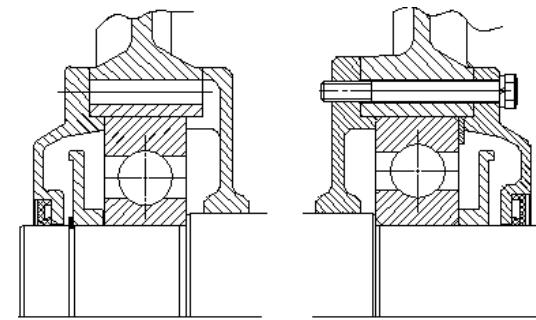

D-End

N-End

5

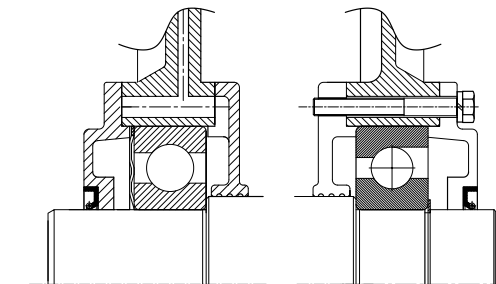

D-End

N-End

6

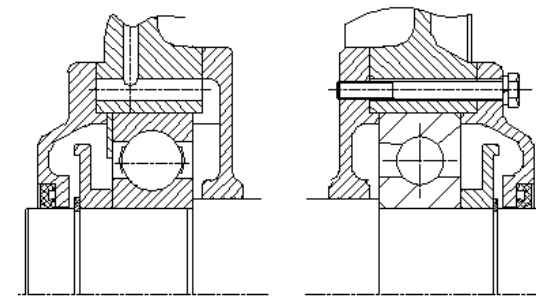

D-End

N-End

7

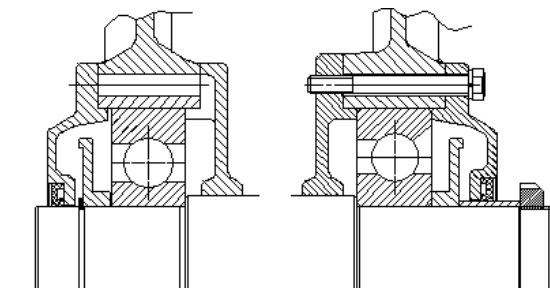

D-End

N-End

AXIAL FORCES - HORIZONTAL MOUNTING

The maximum allowable axial force at the shaft extension for motors are shown in the following table and have the following characteristics:

- standard construction;
- horizontal mounting (mounting arrangement IM B3, IM B35, IM B34);
- operating frequency 50 Hz;
- bearing life of 20000 hours (according to ISO 281:1990);
- bearing operating temperature between -20°C and +70°C;
- no external radial forces;
- motor installed on a rigid foundation with negligible structural vibrations.

Horizontal mounting arrangement								
Frame size	Maximum allowable axial force [N]				Maximum allowable axial force [N]			
	2 poles	4 poles	6 poles	8 poles	2 poles	4 poles	6 poles	8 poles
63	320	400	470	/	180	260	340	/
71	510	620	700	/	210	320	410	/
80	640	800	900	1000	320	460	560	650
90	700	850	1000	1100	320	480	600	700
100	1100	1350	1500	1650	350	520	690	820
112	1200	1500	1700	1800	360	600	800	950
132	1600	2000	2250	2450	530	890	1100	1350
160	2000	2500	2900	3300	2000	2500	2900	3300
180	2300	2800	3200	3400	2300	2800	3200	3400
200	2600	3300	3800	4000	2600	3300	3800	4000
225	3000	3600	4200	4500	3000	3600	4200	4500
250	3300	4000	4600	5000	3300	4000	4600	5000
280	3300	4100	4700	5000	3300	4100	4700	5000
315	4100	6500	7000	8000	4100	6500	7000	8000
355	6500	5000	6100	7000	6500	9000	11000	13000
355K	5000	6000	7000	8000	5000	6000	7000	8000

The corresponding values for motors running at 60 Hz can be obtained by reducing the indicated values by 7% (160-250) and by 10% (280-355). For double-speed motors the higher speed should always be considered.

AXIAL FORCES - VERTICAL MOUNTING

The maximum allowable axial force at the shaft extension for motors are shown in the following table and have the following characteristics:

- standard construction;
- vertical mounting shaft extension downwards (mounting arrangement IM V1, IM V15 only, IM V5, IM V18);
- operating frequency 50 Hz;
- bearing life of 20000 hours (according to ISO 281:1990);
- bearing operating temperature between -20°C and +70°C;
- no external radial forces;
- motor installed on a rigid foundation with negligible structural vibrations.

Corresponding values for motors running at 60 Hz can be obtained by reducing the indicated value by 7% (160÷315) and by 10% (355).

Vertical mounting arrangement								
Frame size	Maximum allowable axial force in downwards direction [N]				Maximum allowable axial force in upwards direction [N]			
	2 poles	4 poles	6 poles	8 poles	2 poles	4 poles	6 poles	8 poles
63	330	420	490	/	170	240	320	/
71	520	640	720	/	200	320	400	/
80	670	840	940	1040	290	430	550	640
90	750	930	1060	1150	290	440	560	670
100	1180	1440	1600	1740	250	460	640	780
112	1180	1450	1620	1760	250	440	620	760
132	1750	2150	2450	2650	460	800	1000	1250
160	2450	3000	3200	3550	2050	2500	2700	3050
180	2900	3300	3800	4000	2400	2500	2900	3000
200	2900	3600	3800	4000	2500	3100	3400	3600
225	3300	3900	4300	4500	2700	3300	3700	3900
250	1500	1700	2000	2200	3300	4000	4600	5000
280	1600	1800	2000	2200	3500	4300	5800	5300
315	1800	2500	2900	3200	4100	6500	7000	8000
355	2700	3400	3900	4200	6500	8000	10000	12000
355K	3000	3700	4300	4700	6700	9300	11000	13000

Vertical mounting arrangement

Frame size	Maximum allowable axial force in downwards direction [N]				Maximum allowable axial force in upwards direction [N]			
	2 poles	4 poles	6 poles	8 poles	2 poles	4 poles	6 poles	8 poles
63	330	440	540	/	310	410	500	/
71	360	480	600	/	330	440	560	/
80	590	780	930	680	540	720	850	980
90	630	840	1000	1150	550	730	880	1050
100	900	1180	1400	1600	750	1050	1250	1400
112	1300	1700	2000	2300	1150	1500	1800	2000
132	1950	2500	3000	3450	1600	2100	2500	2900
160	2900	3800	4500	5050	1100	1440	1690	1950
180	2900	3900	4600	5200	1060	1350	1710	1910
200	3900	5100	6100	6800	900	1200	1450	1700
225	4500	5950	7000	7750	1650	2000	2450	2850
250	5050	6750	7900	8800	1650	1750	2280	2550

RADIAL FORCES - HORIZONTAL MOUNTING

The maximum allowable radial forces at the motor's shaft extension (X_{max}) and shaft collar (X_0) are shown in the following table and have the following characteristics:

- standard construction;
- horizontal mounting (mounting arrangement IM B3, IM B35; IM B34)
- operating frequency 50 Hz;
- bearing life of 20000 hours (according to ISO 281:1990);
- bearing operating temperature between -20°C and +70°C;
- no external axial forces;
- motor installed on a rigid foundation with negligible structural vibrations.

Frame size	Mounting arrangement: IM B3, IM B5							
	2 poles		4 poles		6 poles		8 poles	
	F_{x_0} (N)	$F_{x_{max}}$ (N)	F_{x_0} (N)	$F_{x_{max}}$ (N)	F_{x_0} (N)	$F_{x_{max}}$ (N)	F_{x_0} (N)	$F_{x_{max}}$ (N)
63	350	240	440	280	540	300	/	/
71	430	370	540	460	620	520	/	/
80	620	530	780	660	900	730	990	740
90	680	560	860	710	980	810	1080	890
100	730	590	1200	960	1370	1100	1500	1200
112	740	600	1200	990	1390	1130	1530	1250
132	1450	1190	1950	1600	1950	1600	2250	2000
160	2800	2200	3200	2500	3300	2500	3600	2800
180	3200	2700	3400	2800	3700	3000	3800	3100
200	4400	3700	5000	4100	5400	4500	5400	4500
225	4400	3700	5100	4100	5600	4500	6800	5500
250	5400	4400	5900	3900	6500	5200	6500	5200
280	5800	4800	6200	4200	7000	5400	7000	5400
315	5800	4800	6500	4500	7500	5800	7600	5900
355	5800	4800	7000	4800	8000	6000	8200	6200
355K	5900	4900	8000	5500	8500	6300	9000	6500

The external radial forces between the values $X_0 = 0$ and $X_{max} = E$ can be determined by following their linear relationship.

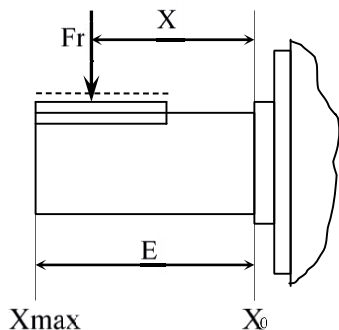

$$F_r = F_{x_0} - \frac{X}{E} * (F_{x_0} - F_{x_{max}})$$

F_{x_0} = maximum radial force on the shaft collar [N]

$F_{x_{max}}$ = maximum radial force at the shaft extension [N]

E = shaft extension length [mm]

X = distance from radial force application point to the shaft collar [mm]

MOTORS FOR HIGH RADIAL LOADS - BEARINGS

The maximum allowable external radial loads for 4-8 pole motors equipped with roller bearings are shown in the following table and have the following characteristics:

- horizontal mounting (mounting arrangement IM B3, IM B35; IM B34);
- operating frequency 50 Hz;
- bearing life of 20000 hours (according to ISO 281:1990);
- bearing operating temperature between -20°C and +70°C;
- no external axial forces;
- motor installed on a rigid foundation with negligible structural vibrations.

In the high radial load configuration, for all frame sizes, the rotor is axially positioned by the N-End bearing.

Horizontal mounting arrangement						
Frame size	4 poles		6 poles		8 poles	
	F_{x_o} (N)	$F_{x_{max}}$ (N)	F_{x_o} (N)	$F_{x_{max}}$ (N)	F_{x_o} (N)	$F_{x_{max}}$ (N)
160	6300	3500	6400	3500	7200	3500
180	6800	4400	7500	4400	7800	4400
200	9600	7600	10400	7600	11000	7600
225	12000	8400	12800	8400	13600	8400
250	14000	9600	15000	9600	16000	9600
280	20000	7500	22500	7500	24000	7500
315	25500	9800	29500	9800	32000	9800
355	36000	10500	41500	10500	45000	10500
355K	41000	12000	48000	12000	52000	12000

Horizontal mounting arrangement				
Frame size	2 poles		4 poles - 6 poles - 8 poles	
	D-End	N-End	D-End	N-End
160	6309-C3	6309-C3	NU309-C3	6309-C3
180	6311-C3	6311-C3	NU311-C3	6311-C3
200	6312-C3	6312-C3	NU312-C3	6312-C3
225	6313-C3	6313-C3	NU313-C3	6313-C3
250	6314-C3	6314-C3	NU314-C3	6314-C3
280	6314-C3	6314-C3	NU317-C3	6317-C3
315	6316-C3	6316-C3	NU319-C3	6319-C3
355	6319-C3	6319-C3	NU322-C3	6322-C3
355K	6319-C3	6319-C3	NU322-C3	6322-C3

A straight roller bearing can only be used when the bearing itself is subjected to a constant radial load. Otherwise, the motor must be ordered with ball bearings.

TERMINAL BOX AND CABLE ENTRY

The terminal boxes of all motor series in standard configuration are placed on top of the electrical machine (considering IM 1001-B3 as reference) and are normally equipped with 6 leads.

Aluminium motors allow the user to mount the terminal box either on the right or the left side, as seen from the D-End side.

- cast iron motors 63÷132 can be supplied only with terminal box on top;
- cast iron motors 160÷355 can be supplied with lateral terminal box on request;
- 63÷90 frame motors: rotatable terminal box of 90°;
- 100÷355 frame motors: rotatable terminal box of 180°.

A_C 63-180				
Frame size	Type of terminal	Terminal size	Maximun cable diameter (mm)	Clearance holes for metric cable glands
A1C / A2C 63-71	Threaded terminals	M4	10	M18×1.5
A_C 80		M4	12	M20×1.5
A_C 90-100		M4		M20×1.5 +M16×1.5 (aux)
A_C 112-132		M5	12	2-M20×1.5 +M16×1.5 (aux)
A_C 160-180		M6	25	2-M32×1.5 +M16×1.5 (aux)

B_C 71-355				
Frame size	Type of terminal	Terminal size	Maximun cable diameter (mm)	Clearance holes for metric cable glands
B_C 71-80	Threaded terminals	M4	18	M25×1.5
B_C 90-100		M4	18	M25×1.5 +M16×1.5 (aux)
B_C 112-132		M5	25	2-M32×1.5 +M16×1.5 (aux)
B_C 160-180		M6	32	2-M40×1.5 +M16×1.5 (aux)
B_C 200-225		M8	38	2-M50×1.5 +M16×1.5 (aux)
B_C 250-280		M10	44	2-M63×1.5 +M16×1.5 (aux)
B_C 315		M12	44	2-M63×1.5 +M16×1.5 (aux)
B_C 355		M20	44	2-M63×1.5 +M16×1.5 (aux)

TERMINAL BOXES - DIMENSIONS

Motors in standard configuration are supplied with a main terminal box in the following dimensions:

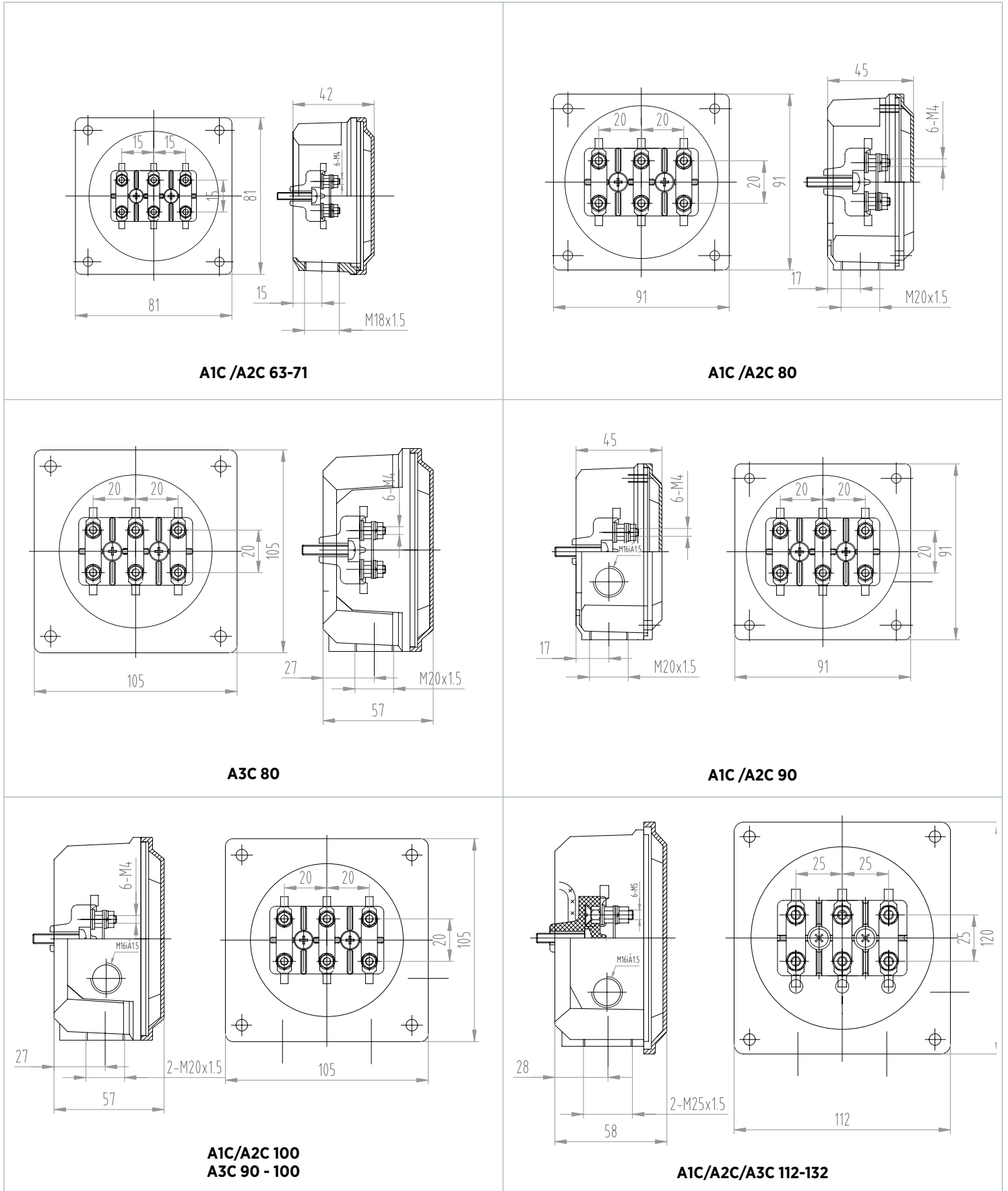

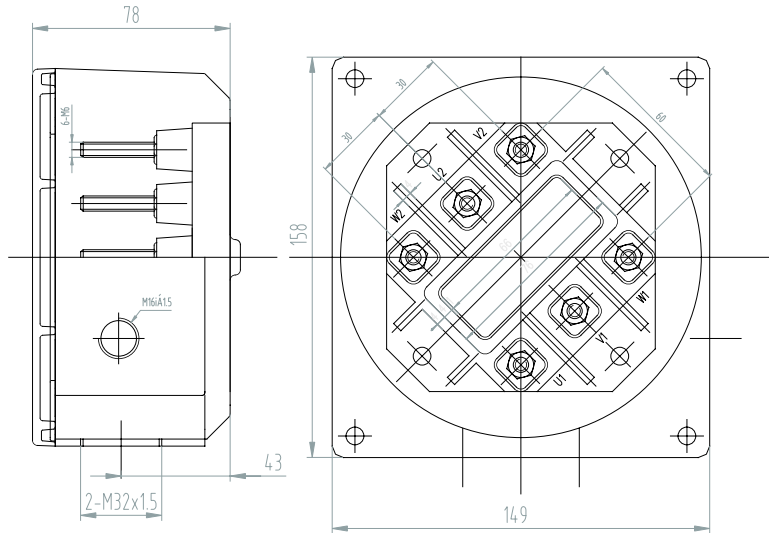

A1C /A2C/A3C 160-180

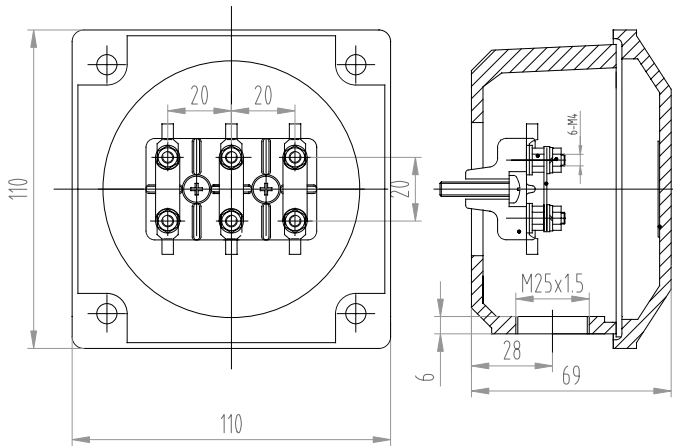

**B1C /B2C 71
B1C /B2C/ B3C 80**

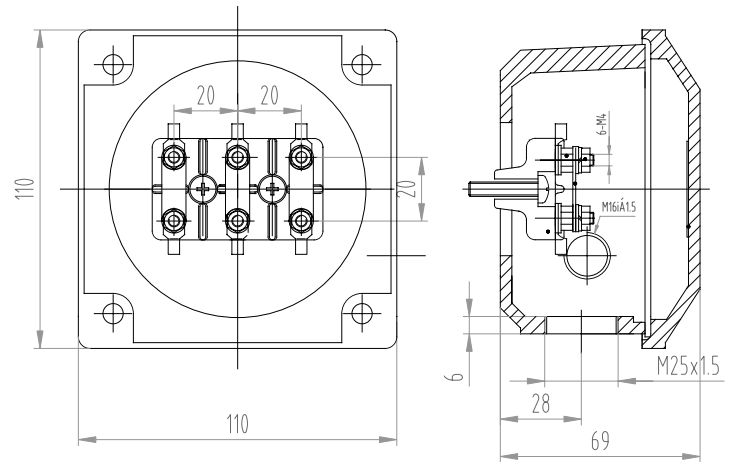

B1C /B2C/B3C 90-100

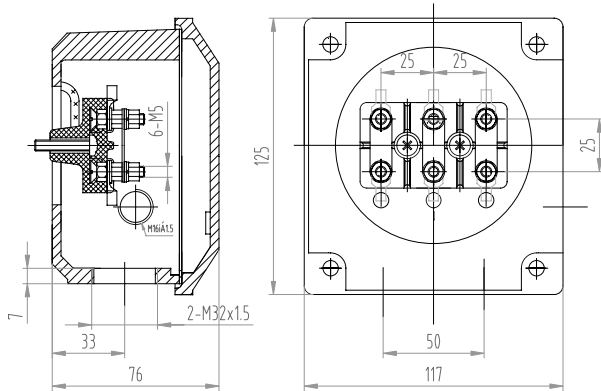

B1C /B2C/B3C 112-132

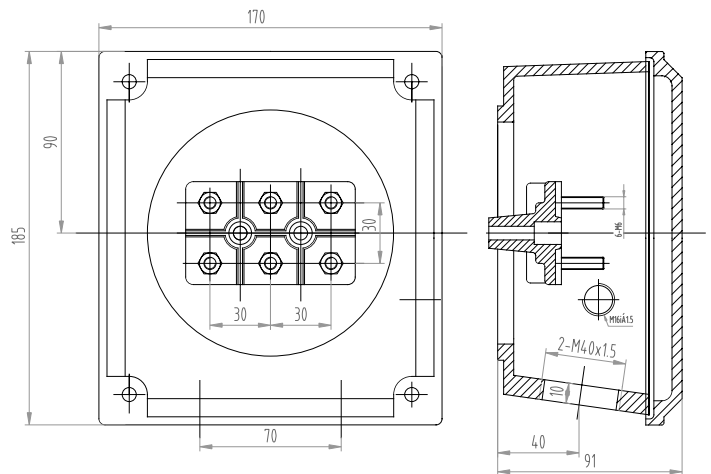

B1C /B2C/B3C 160-180

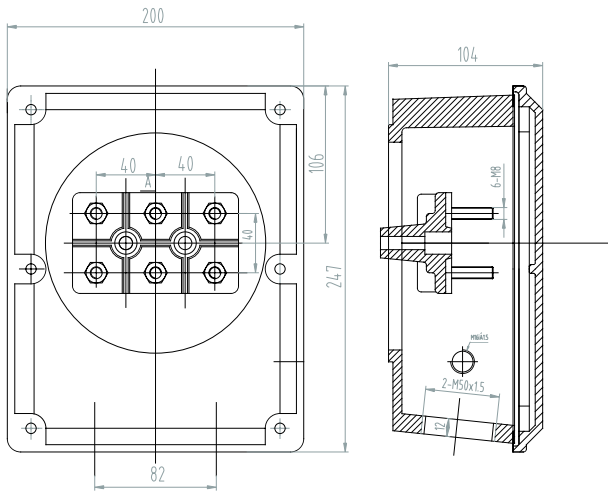

B1C /B2C/B3C 200-225

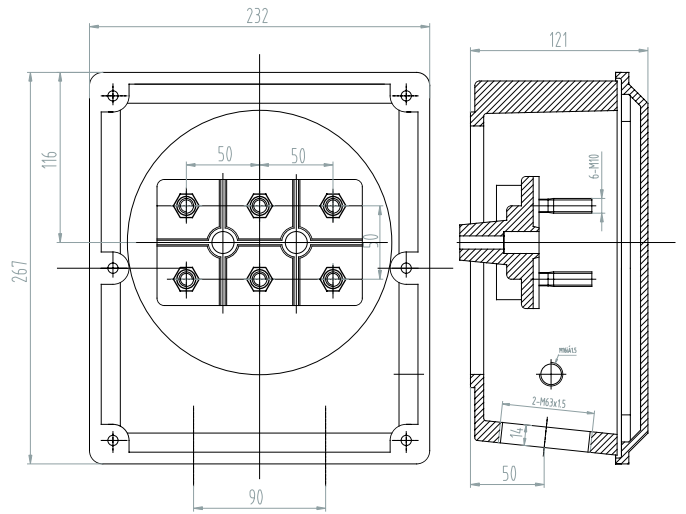

B1C /B2C/B3C 250-280

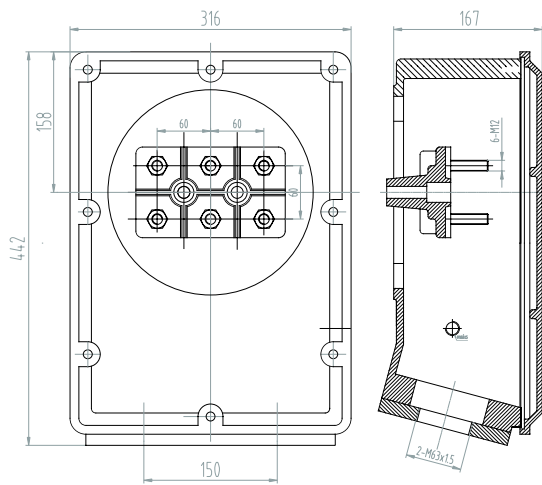

B1C /B2C/B3C 315

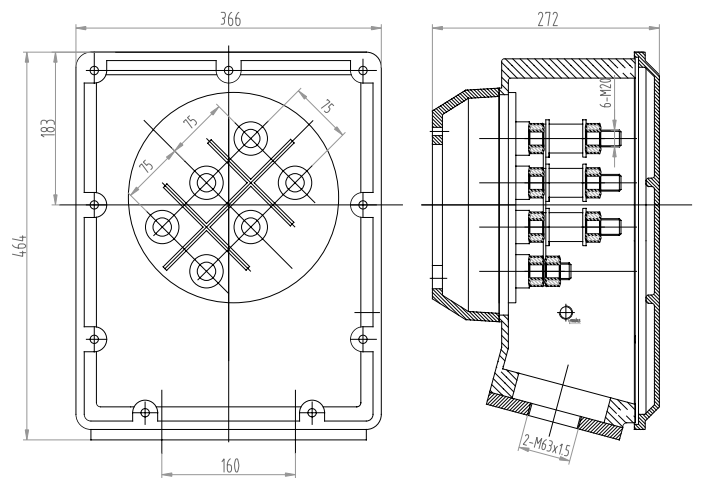

B1C /B2C/B3C 355

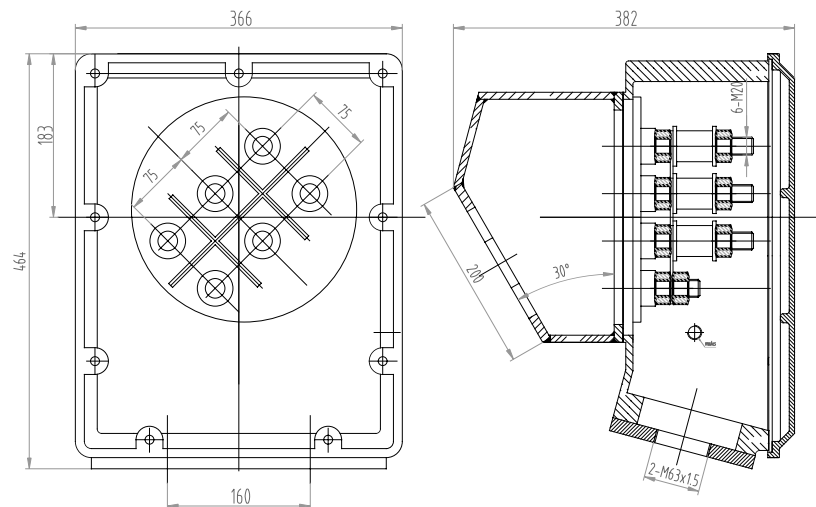

B1C /B2C/B3C 355K

AUXILIARY TERMINAL BOXES

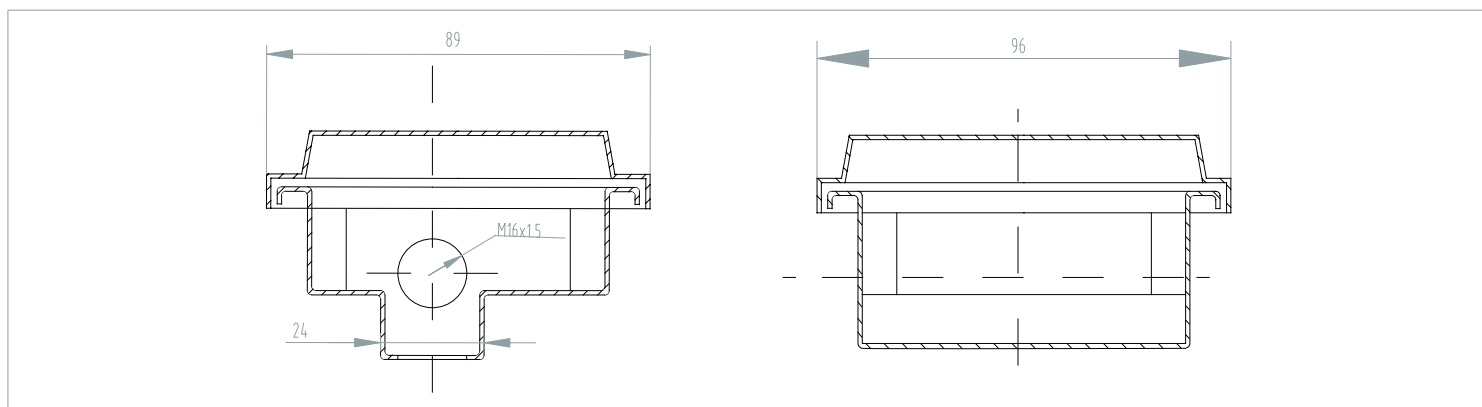

The auxiliary terminal box is positioned on the opposite side of cable holes. See below:

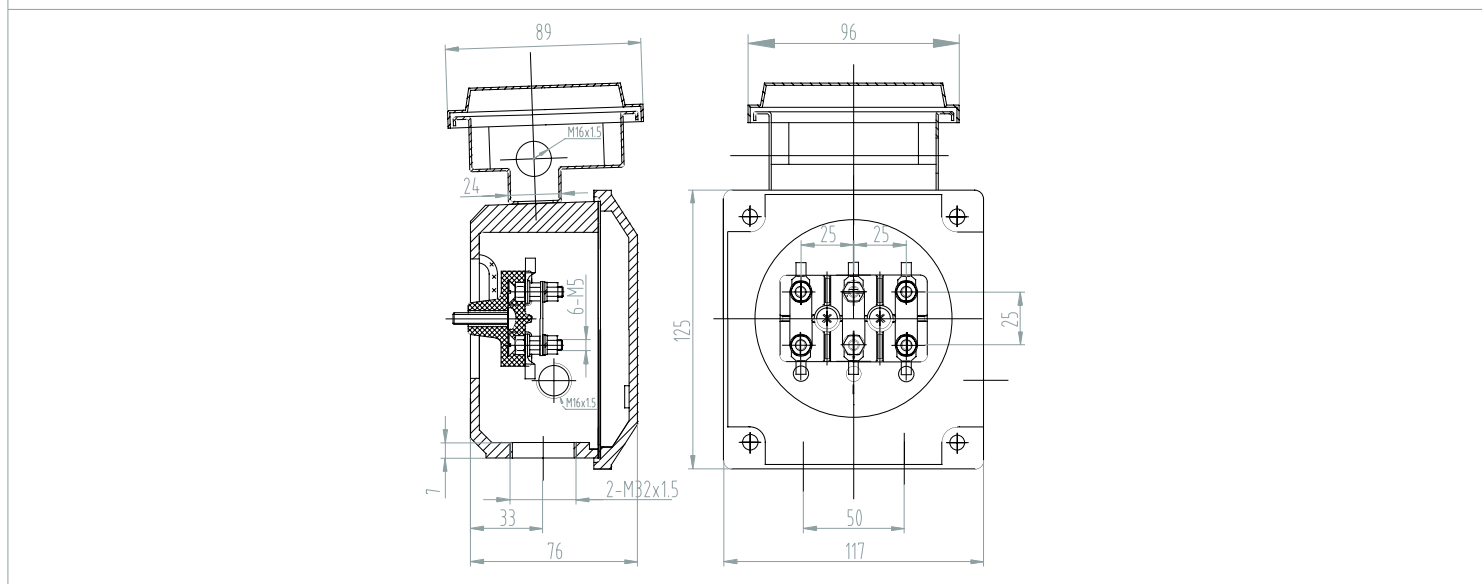

GROUNDING

Motors in standard configuration are provided with the following grounding terminals:

Aluminium MOTORS	Frame size									
	63	71	80	90	100	112	132	160	180	
IE1	C1	C2								
IE2		C2								
IE3	-	-	C1				C2			
CAST IRON MOTORS	Frame size									
	63	71	80	90	100	112	132	160	180-355	
IE1	C1	C2								
IE2		C2								
IE3	-	-	C2							

C1 | Configuration 1: n°1 terminal in main terminal box.

C2 | Configuration 2: n°2 terminals, one inside the terminal box and one outside.

CONDENSATION DRAINAGE

When installed outdoors or used for intermittent work in environments with high humidity levels, motors can be provided with holes for condensation drainage.

In order to ensure the correct positioning of the holes, the operating position of the motors must be specified.

- Motors with frame sizes from 280 to 355 have holes for condensation drainage as standard.
- Motors from 63-250 frame size can be supplied with drainage holes on request.

ANTICONDENSATION HEATERS

Motors subject to atmospheric condensation, either through standing idle in damp environments or because of wide ambient temperature variations, may be fitted with anticondensation heaters. Anticondensation heaters are normally switched on automatically when the supply to the motor is interrupted, heating the motor to avoid water condensation. They are normally mounted on D-End winding heads. Motors can be supplied with anticondensation heaters with terminals in main terminal box.

Frame size	Power (W)
63-112	10
132-160	30
180-200	50
225-250	65
280	100
315S	130
315M	200
355/355K	300

THERMAL PROTECTIONS

Standard magnetothermal circuit breakers are sufficient to suitably protect the motor from overloading. Motors can be supplied with the characteristics described in the following table:

Type	Operating principle	Active temperature [°C]	Frame size where applicable	Mark	Solution
Bimetallic devices PTO	Motoprotectors with contact normally closed. The disc opens when the winding temperature reaches limits dangerous to the insulation system of the motor	150	63-355	Optional	3 connected in series in windings (one per phase)
Positive temperature coefficient thermistors PTC	At the active temperature this device quickly changes its resistance value.	150	63-355	Standard for size 160 to 355 with terminals in main terminal box	3 connected in series in windings (one per phase)
Platinum resistance thermometer PT100	Variable linear resistance with the winding temperature, particularly suitable for a continuous winding temperature monitoring.	Set up in control panel	63-355	Optional	3 mounting in winding

CONNECTION DIAGRAMS

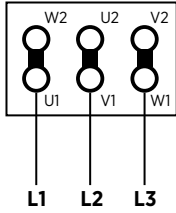
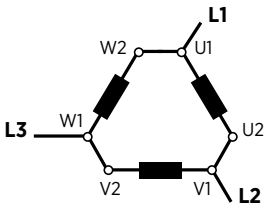
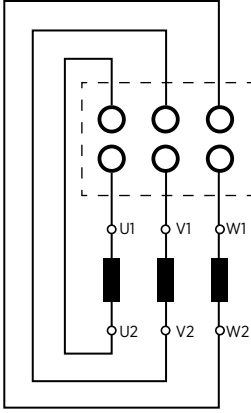
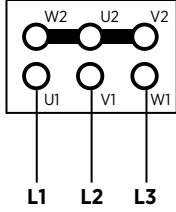
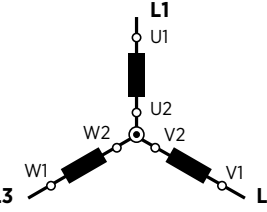
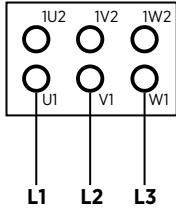
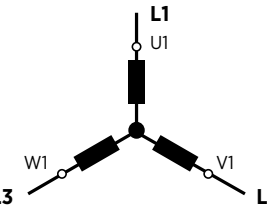
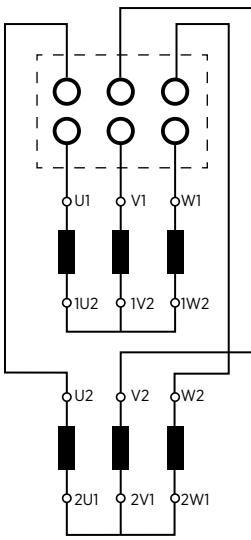
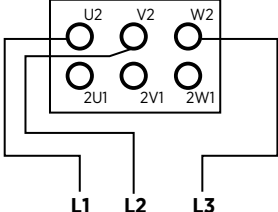
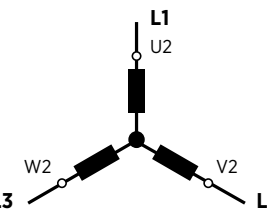
Voltage and Connection	External Connection Diagram	Outline Diagram	Internal Connection Diagram
<p>MOTORS WITH 6 TERMINALS Δ / Y CONNECTION</p>			
			
<p>TWO SPEED MOTORS WITH 6 TERMINALS AND TWO SEPARATE WINDINGS</p>	<p>Low Speed (LSP)</p> 		
	<p>High Speed (HSP)</p> 		

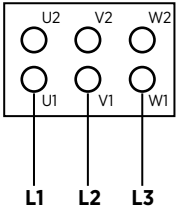
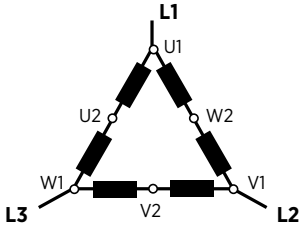
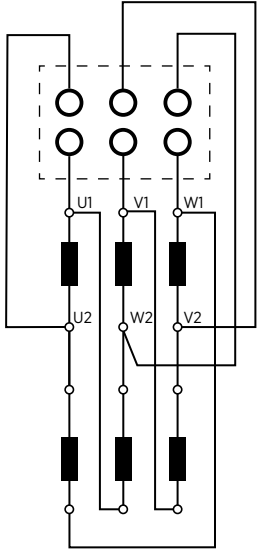
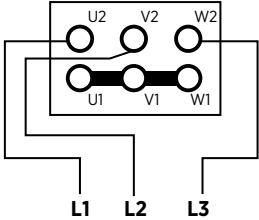
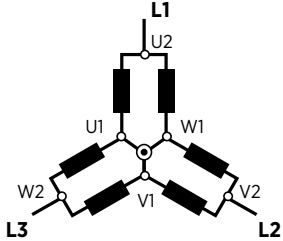
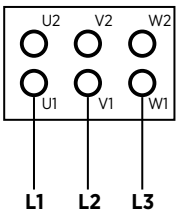
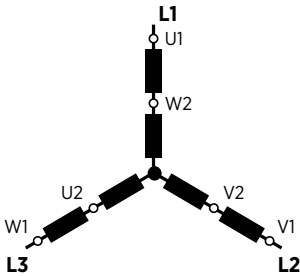
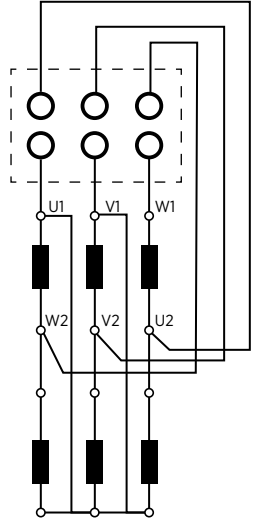
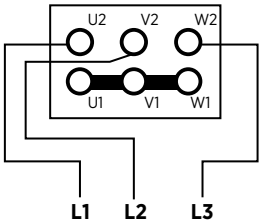
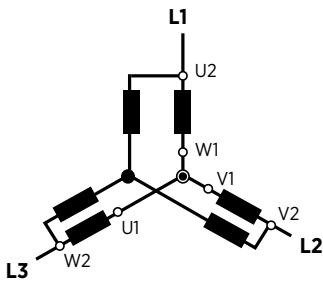
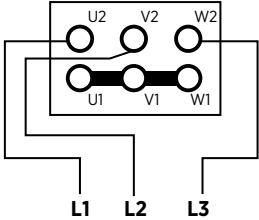
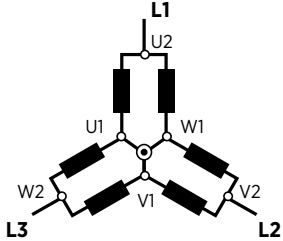
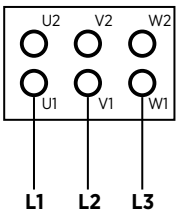
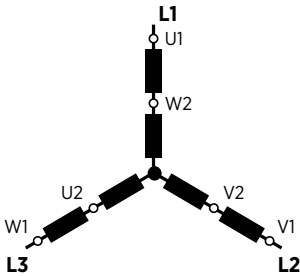
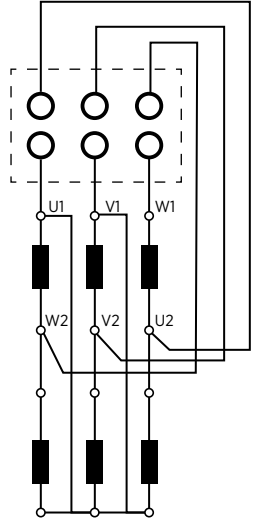
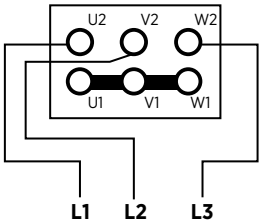
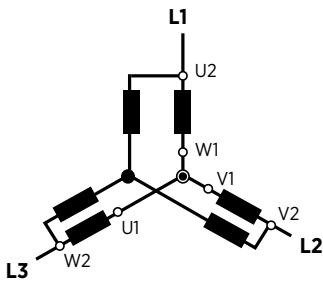
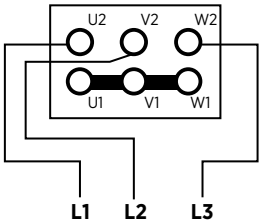
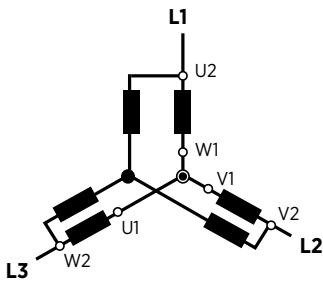
Voltage and Connection	External Connection Diagram	Outline Diagram	Internal Connection Diagram								
<p>TWO SPEED MOTORS WITH 6 TERMINALS AND Δ / YY CONNECTION</p>	<p>Low Speed (LSP)</p> 			<p>High Speed (HSP)</p> 	<p>High Speed (HSP)</p> 	<p>TWO SPEED MOTORS WITH 6 TERMINALS AND Y / YY CONNECTION</p>	<p>Low Speed (LSP)</p> 			<p>High Speed (HSP)</p> 	<p>High Speed (HSP)</p> 
	<p>High Speed (HSP)</p> 	<p>High Speed (HSP)</p> 									
<p>TWO SPEED MOTORS WITH 6 TERMINALS AND Y / YY CONNECTION</p>	<p>Low Speed (LSP)</p> 			<p>High Speed (HSP)</p> 	<p>High Speed (HSP)</p> 						
	<p>High Speed (HSP)</p> 	<p>High Speed (HSP)</p> 									

STARTING

The performances of a motor in the starting phases are, in first approximation, related to the corresponding feeding voltage by the following relationships:

- The starting current almost varies directly with the motor feeding voltage: $I/I_n \propto U/U_n$.
- The starting torque (T_s) and the maximum torque (T_m) of the motor is almost varying directly with the square of the feeding voltage: $T/T_n = (U/U_n)^2$.

Below is an example of starting current and torque characteristics modification when voltage varies from 100% of U_n to 80% of U_n :

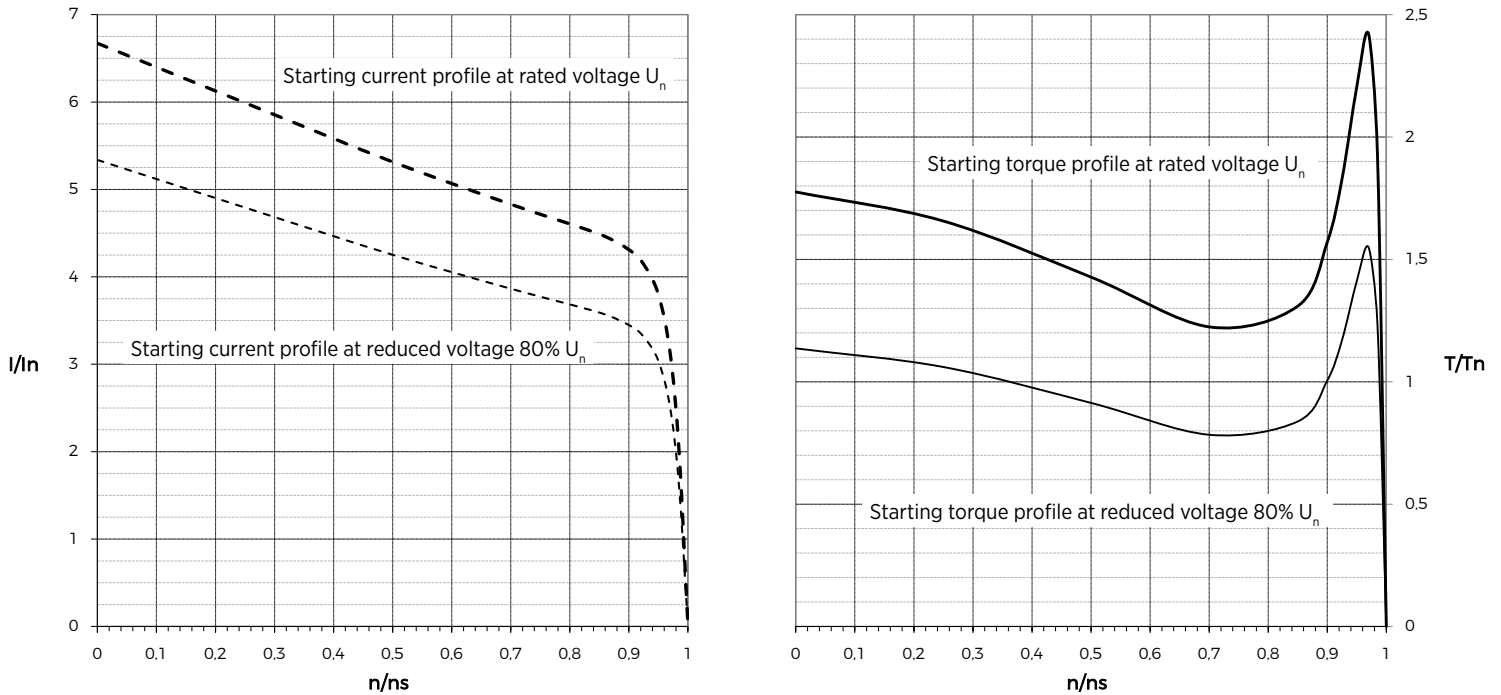

STARTING RESPONSE

The starting current values given in p.u. and detailed in the present catalogue allow to obtain the starting current r.m.s. values, and so measured after some sinusoidal periods from insertion: in the first instant it is possible to have peak currents which can be up to 2.5 times the stable values." The amplitude of the peaks depends on the instantaneous value of the sinusoidal supply voltage at the moment of insertion. These peaks are rapidly dampened. Because of their analogue behaviour, the starting torque peaks come considerably attenuated by the inertia of the motor and the coupling load, with negligible resulting stress of the shaft and coupling.

TYPE OF STARTING

Knowing the torque versus speed diagram of the load driven by the motor is the first fundamental point to evaluate which type of starting method can be used in the system: the motor coupled to the load can be started positively only when the accelerating motor torque is higher than the required load torque in all the speed ranges of the starting process (from zero to the nominal speed). Torque load diagrams are mainly divided in the following categories:

- **Machines with quadratic torque versus speed diagram:** typically these machines can be centrifugal pumps, ventilators, propellers or screw compressors;
- **Machines with constant torque versus speed diagram:** typically, these can be paper continuative machines, refrigeration piston compressors, or skiing cable cars;
- **Machines with proportional torque versus speed diagram:** typically, these are rolling mills or liquid ring pumps.

During starting, close attention is usually paid to the starting current, which can achieve very high values for Direct-on-Line (D.O.L.) starting. Considering all these factors, an appropriate starting system can be chosen.

The most common starting methods are the following:

1. Direct-on-line starting (D.O.L.)

D.O.L. starting means the direct insertion of the motor at its nominal voltage and frequency values. In these conditions the starting torque and current are those given in the catalogue.

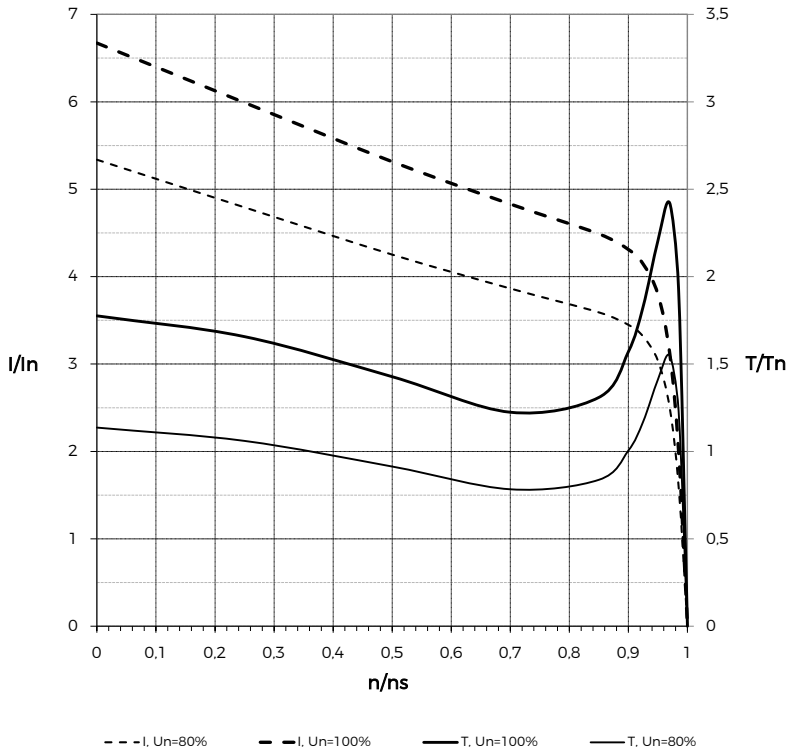

2. Star-Delta starting (Y / Δ)

With this method both the starting torque (—▲—) and the current (—●—), will be reduced by approximately 30% of the correspondent value indicated for D.O.L. starting in the starting phase (with a negligible transient at delta insertion). This starting method can be adopted in cases where the resistant torque is very low and low starting currents are also requested.

A motor that should be started with star-delta device should have all six winding terminals in the main terminal box and the motor should be designed for delta connection when fed at nominal voltage/frequency.

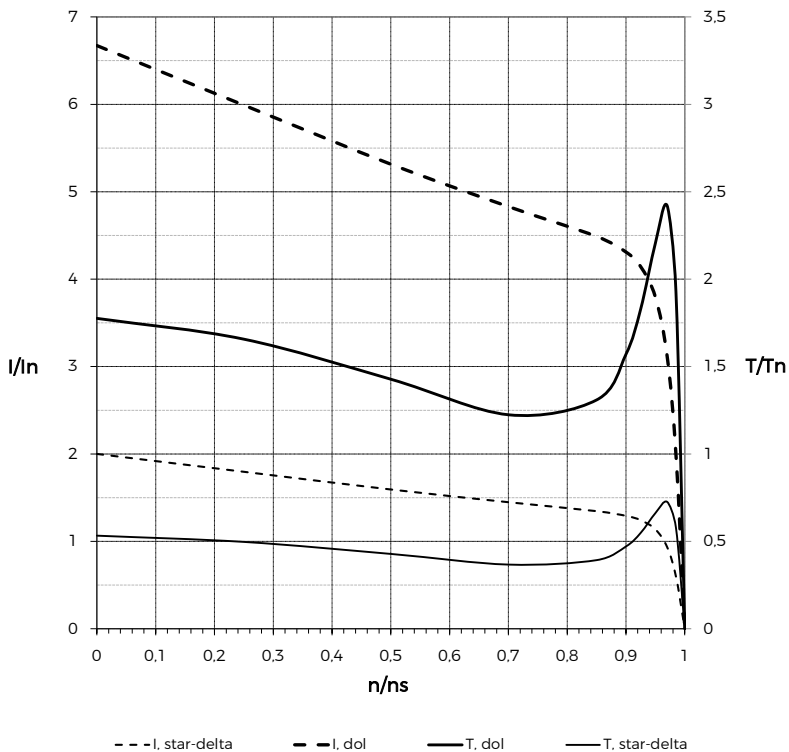

3. Autotransformer starting (A.T.)

When the starting is realised by the use of an autotransformer, the voltage ratio ($K = U_{at}/U_n$) between the output and input of the transformer during the starting should be considered. In these conditions, the starting performances will be as in the following. The use of an autotransformer allows the starting current to be reduced, but also results in a lower motor torque characteristic. Functioning is given with the following relationships:

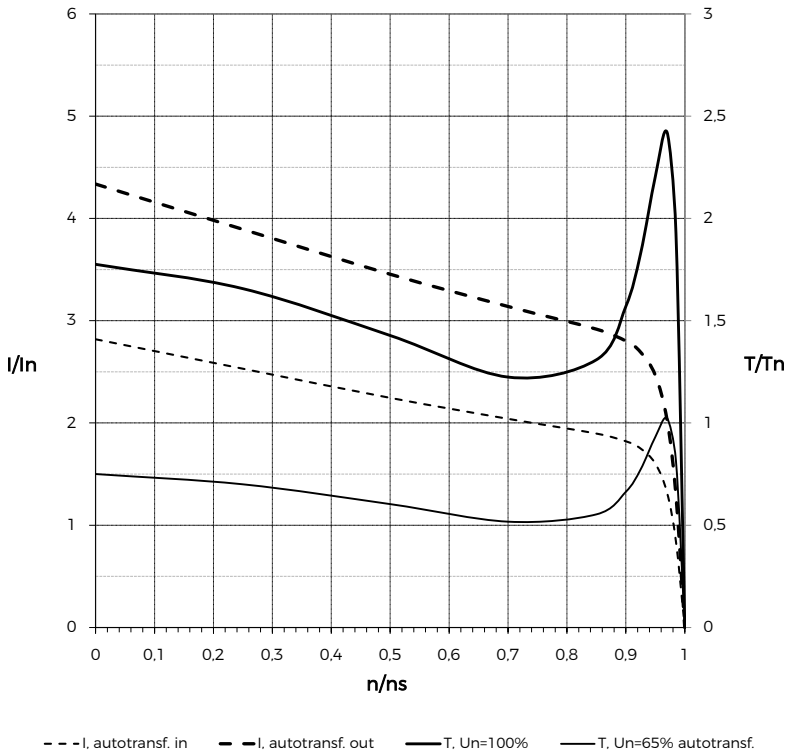

$$I_{A.T.} = I_n \cdot \left(\frac{U_{A.T.}}{U_n} \right)^2 = I \cdot K^2 \qquad I_m = I_n \cdot \frac{U_{A.T.}}{U_n} = I_n \cdot K$$

$$C_{A.T.} = C_{D.O.L.} \cdot \left(\frac{U_{A.T.}}{U_n} \right)^2 = C_{D.O.L.} \cdot K^2$$

U_n = motor nominal voltage [U]

I_n = motor nominal current [A]

$I_{D.O.L.}$ = motor starting current at nominal voltage

$I_{A.T.}$ = reduced starting current seen by the main supply (input side of autotransformer [A])

$C_{A.T.}$ = starting motor torque at reduced voltage $U_{A.T.}$

$U_{A.T.}$ = reduced voltage at the exit of autotransformer [U]

I_m = motor starting current at voltage $U_{A.T.}$ [A]

$C_{D.O.L.}$ = starting torque at nominal voltage

4. Soft starter starting

The soft starter can be seen as a device that gradually increases the voltage during the starting process, limiting the starting current at a fixed value (the limited current usually ranges from 1,5 to 3 times the nominal current).

Because the limited current is fixed during the starting, the torque diagram will be consequently reduced in almost direct correlation with the square ratio of the limited current and the correspondent D.O.L. current.

This method of starting is recommended for machines with very low torque profile at low speed.

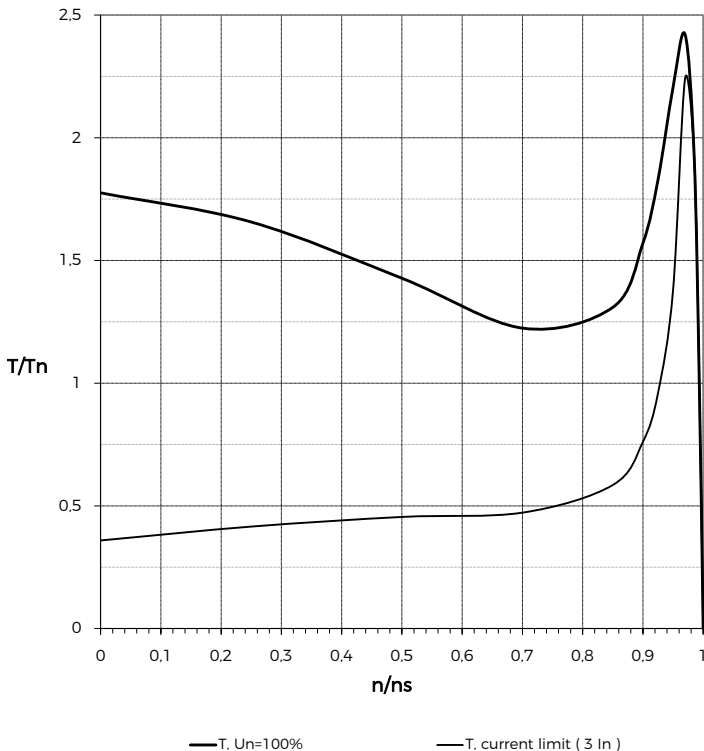

MOTORS FOR VARIABLE SPEED APPLICATIONS

A.C. motors designed for sinusoidal feeding voltage and constant feeding frequency can, under normal conditions, be used in variable speed applications with the use of a frequency converter. Motors for variable speed applications are generally fed by the frequency converter by upholding the relationship U_n/f_n up to the speed correspondent to the nominal voltage and frequency and, for higher speeds, by increasing the frequency and keeping the nominal voltage value constant.

The performances of a motor fed by a frequency converter depends on the cooling type: self-ventilated motors are suitable for use at loads with quadratic torque/speed shapes, which is typically the case for pumps and fans.

When constant torque is required from low speeds, forced ventilation must be employed.

Generally, the motor type can be chosen by referring to the following diagram and considering the torque diagram of the motor, its speed range and its cooling type.

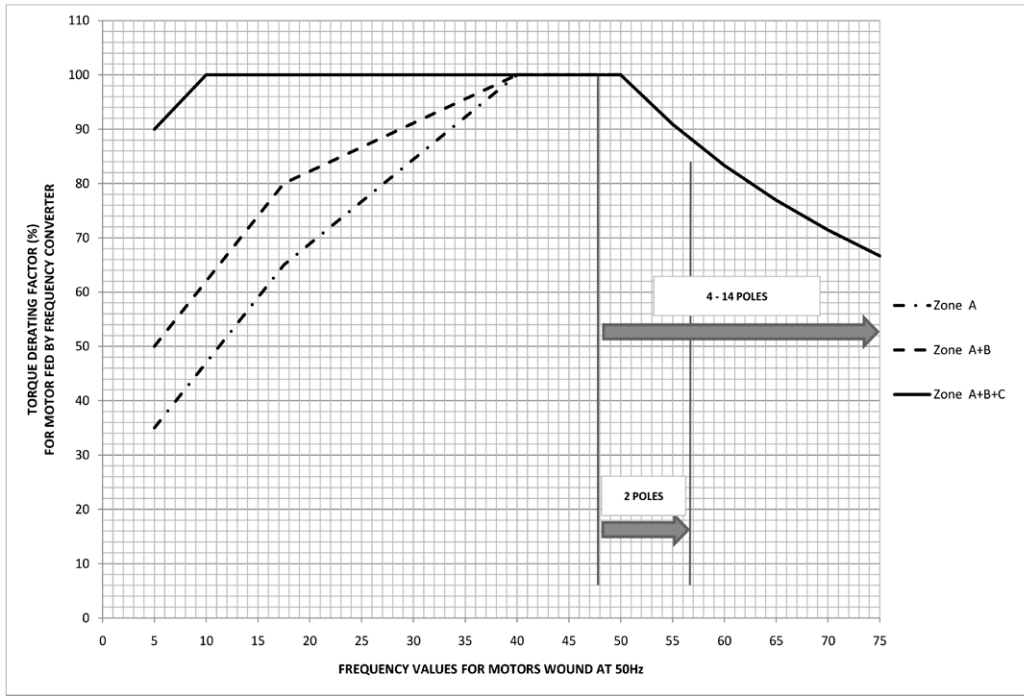

In both cases the resistant torque of the driven machine must be lower than the leading torque of the motor for the total running speed range.

The speed range is set from a minimum frequency F_{MIN} (typically around 5-10 Hz depending on the converter), and a maximum frequency F_{MAX} given by the speed limits of the rotating system and/or the reduction in torque.

Cooling Method IC 411	Poles	Frame size
Zone A + B	2 - 12	≥ 355
Zone A	6 - 8	≤ 315
Zone A + B	2 - 4	≤ 315
Cooling Method IC 416	Poles	Frame size
Zone A + B + C	2 - 12	≤ 355

Use of the frequency converter requires some precautions regarding the voltage peaks and wave-fronts. The values of the peaks depend on the supply voltage of the motor feeding cable length.

Motors fed by frequency converters can be subject to voltages between the D-End and N-End bearing arrangements. This is due to the effects of the feeding system. The values of the aforementioned voltages depend on the characteristics of the frequency converter and on the dimensions of the motor itself. For motors from the 315 frame size or those where the shaft peak voltage exceeds 500 mV, Marelli Motori suggest to insulate one of the motor's bearing arrangements. Normally this solution is applied to the N-End of the motor. These guidelines, coupled with the correct grounding of the operating system, motor and coupled machine, guarantee the best results.

MOTORS FOR FORCED VENTILATION

The forced ventilation is available as an optional for specific applications.

Frame size	ΔL (mm)	P[W]	In[A]			r/min		Air volume (m ³ /h)		Air pressure (Pa)		Weight (Kg)
			380V	400V	440V	50Hz	60Hz	50Hz	60Hz	50Hz	60Hz	
160	265	90	0,33	0,31	0,29	2800	3350	1700	1850	150	160	6
180	280	100	0,33	0,31	0,29	2800	3350	2000	1950	140	150	8
200	280	180	0,65	0,62	0,56	1400	1680	3000	3200	92	100	9,5
225	280	180	0,65	0,62	0,56	1400	1680	3200	3500	90	98	12,5
250	300	370	1,12	1,06	0,97	1400	1680	4000	4300	105	115	14,5
280	325	370	1,4	1,33	1,21	1400	1680	5500	6000	120	130	18
315	270	800	1,93	1,83	1,67	1400	1680	6000	6300	150	160	25
355	340	800	1,93	1,83	1,67	1400	1680	6200	6500	150	160	30

INSTALLATION ≤ 1000 M A.S.L.

The performance of standard motors is considered at a maximum height of 1000 m a.s.l., with motors running in continuous duty, at nominal voltage , frequency and a maximum ambient temperature of 40°C.

DERATINGS

Should the environmental conditions be different from the conditions given by the IEC 60034-1 S6 international standard (continuous duty S1, at 50 Hz for rated voltage, 40°C ambient temperature, and an altitude up to 1000 m a.s.l.), the output ratings are obtained by applying the factors as per the following table.

Altitude (m) a.l.m.	Ambient Temperature (°C)						
	30	35	40	45	50	55	60
1000	/	/	1	0,95	0,92	0,88	0,83
1500	/	1	0,97	0,92	0,90	0,85	0,82
2000	1	0,95	0,94	0,90	0,87	0,83	0,80
2500	0,96	0,93	0,90	0,88	0,85	0,81	0,77
3000	0,90	0,90	0,86	0,85	0,82	0,78	0,75
3500	0,90	0,88	0,82	0,81	0,80	0,76	0,73
4000	0,86	0,84	0,80	0,78	0,77	0,73	0,70

EFFICIENCY AND POWER FACTOR

The rated output efficiency (η) and power factor ($\cos\Phi$) are given in the technical data tables for each motor. The values for other loads can be estimated from the following tables.

Efficiency(η) and power factor($\cos\Phi$) at									
5/4		4/4		3/4		2/4		1/4	
of rated load									
η	$\cos\Phi$	η	$\cos\Phi$	η	$\cos\Phi$	η	$\cos\Phi$	η	$\cos\Phi$
96	0,91	96	0,91	96	0,88	94,5	0,82	90	0,64
95	0,90	95	0,90	95	0,87	93,5	0,81	89	0,63
94	0,89	94	0,89	94	0,86	92	0,8	87	0,60
93	0,88	93	0,88	93	0,85	91	0,79	86	0,60
92	0,87	92	0,87	92	0,84	90	0,78	85	0,58
91	0,87	91	0,86	91	0,83	89	0,77	84	0,57
90	0,86	90	0,85	90	0,82	88	0,76	82	0,56
89	0,85	89	0,84	89	0,81	87	0,75	81	0,55
88	0,84	88	0,83	88	0,8	86	0,74	80	0,54
86	0,83	87	0,82	87	0,78	85,5	0,71	79,5	0,52
85	0,82	86	0,81	86	0,76	84,5	0,69	78,5	0,50
84	0,82	85	0,80	85	0,75	83	0,68	77	0,48
83	0,81	84	0,79	84	0,73	82,5	0,66	75,5	0,46
82	0,80	83	0,78	83	0,73	81	0,66	74	0,46
81	0,79	82	0,77	82	0,72	80	0,65	73	0,44
79	0,78	81	0,76	81	0,7	79,5	0,63	72,5	0,43
78	0,77	80	0,75	80	0,69	78	0,62	71	0,42
77	0,76	79	0,74	79	0,67	77,5	0,59	70,5	0,40
76	0,75	78	0,73	78	0,66	76	0,58	69	0,38
75	0,74	77	0,72	77	0,65	75	0,57	68	0,36
74	0,73	76	0,71	76	0,64	74	0,56	67	0,36
73	0,72	75	0,70	75	0,63	73	0,55	66	0,35
72	0,71	74	0,69	74	0,62	72	0,54	64	0,34
71	0,70	73	0,68	73	0,61	71	0,53	63	0,34
70	0,69	72	0,67	72	0,59	70	0,51	62	0,33
69	0,68	71	0,66	71	0,58	69	0,49	61	0,32
68	0,67	70	0,65	69,5	0,57	67,5	0,48	59,5	0,32
67	0,66	69	0,64	69	0,56	66	0,47	58	0,31
66	0,66	68	0,63	67	0,55	65	0,46	57	0,31
65	0,65	67	0,62	66	0,53	64	0,44	55	0,30
64	0,64	66	0,61	65	0,52	63	0,43	54	0,29
63	0,63	65	0,60	64	0,52	62	0,41	53	0,28
62	0,62	64	0,59	63	0,51	61	0,4	52	0,27
61	0,61	63	0,58	62,5	0,5	60,5	0,39	51,5	0,26
60	0,60	62	0,57	62	0,5	59	0,39	49	0,24
59	0,59	61	0,56	61	0,49	58	0,38	48	0,22
58	0,58	60	0,55	60	0,48	57	0,37	47	0,21

TOLERANCES FOR ELECTROMECHANICAL CHARACTERISTICS

Tolerances for electromechanical characteristics in accordance with the IEC 60034-1 standard.

Efficiency η	-15% of $(1 - \eta)$ for $P_{nom} \leq 150$ kW -10% of $(1 - \eta)$ for $P_{nom} > 150$ kW
Power factor	-1/6 $(1 - \cos\phi)$ Minimum absolute value 0.02 Maximum absolute value 0.07
Slip	$\pm 20\%$ for $P_{nom} \geq 1$ kW $\pm 30\%$ for $P_{nom} < 1$ kW
Locked rotor current	+20% of the current
Locked rotor torque	-15% +20% of the torque
Run up torque	-15% of the value
Breakdown torque	-10% of the value
Moment of inertia	$\pm 10\%$
Noise	+3 dB(A)
Vibration	+10% of the guaranteed class

VOLTAGE AND FREQUENCY

The motors described in this catalogue have nominal ratings and performances referred to the nominal voltage mentioned in the main nameplate, according to the IEC 60034-1 international standard. This standard classifies voltage and frequency variations in areas A and B, as shown in the following figure.

Area A - The motor shall be capable of performing its primary function continuously, but need not comply fully with its performance at rated voltage and frequency and may exhibit some deviations.

Area B - In this area the motor shall be capable of performing its primary function, but may exhibit greater deviations from its performance at rated voltage and frequency than in zone A. Extended operation at the perimeter of zone B is not recommended.

The motors can be wound for special voltage and frequency values, on request.

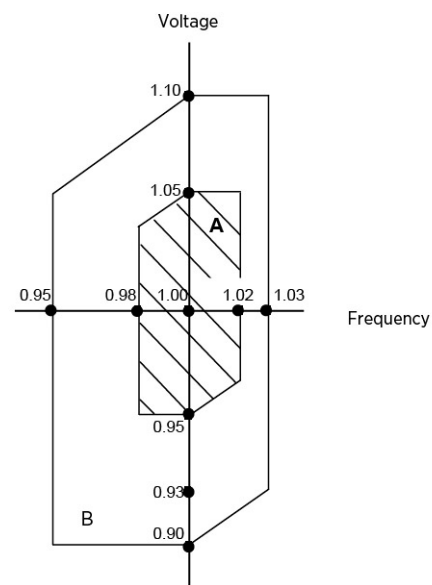

OPTIONS AND CONFIGURATIONS

Options available are listed in the following prospect. There are options which can not be selected together.

Option	Description	63÷132	160÷355
100	Insulation class H	o	o
102	N° 9 Terminals	o	o
103	N° 12 Terminals	o	o
105	VPI Impregnation	s	s
107	Tropicalization	o	o
108	Anticondensation heaters, with terminals in main terminal box	o	o
109	Anticondensation heaters, with terminals in auxiliary terminal box	o	o
110	Bi-metal cut-out switch with terminals in main terminal box	o	o
111	PTC thermistors with terminals in main terminal box	o	s
112	PT100 thermodetectors with terminals in main terminal box	o	o
113	Bi-metal cut-out switch with terminals in auxiliary terminal box	o	o
114	PTC thermistors with terminals in auxiliary terminal box	o	o
115	PT100 thermodetectors with terminals in auxiliary terminal box	o	o
120	Transducer for thermodetectors PT100	n/a	o
122	PT100 thermodetector in D-End bearing - single element	n/a	o
123	PT100 thermodetector in D-End bearing - double element	n/a	o
124	Protection degree IP66	o	o
125	Protection degree IP56	o	o
126	Protection degree IP65	o	o
127	Second shaft end	o	o
128	Sealed bearings	o	o
129	Roller bearings on D-End	n/a	o
129bis	N-End angular contact bearing for high axial loads (vertical mounting)	n/a	o
130	Oil seal	s	o
131	Drainage hole with tap	o	o/s ⁽¹⁾
133	Vibration level B	o	o
134	Metallic Fan	o	o
136	D-End special shaft extension	o	o
137	Low temperature duty -25°C. -40°C	o	o
138	D-End and N-End grease nipples	n/a	s

Key

s = standard

o = optional

n/a = not available

(1) Optional on 63-250 frame motors, standard on 280-355 motors.

OPTIONS AND CONFIGURATIONS

Options available are listed in the following prospect. There are options which can not be selected together.

Option	Description	63÷132	160÷355
139	Arrangement for SPM D-End side	n/a	o
140	Complete with vibration transducer D-End side standard type (CEMB)	n/a	o
141	Complete with vibration transducer D-End side Bently Nevada type	n/a	o
160	Arrangement for encoder standard type	o	o
160bis	Arrangement for encoder special type	o	o
161	Complete with encoder standard type	o	o
165	Brake adaptation like Precima or Pintsch Bubenzer	o	o
171	Anti sun canopy	o	o
174	Locked D-End bearing	o	s
177	3-Phase forced ventilation	o	o
179	Special fan for reduced noise level	o	o
180	Insulated N-End bearing - Horizontal Mounting (≥ 280 frame)	n/a	o
181	Insulated N-End bearing - Vertical Mounting (≥ 280 frame)	n/a	o
188	Enhanced insulation system for Inverter $\geq 500V$ (≥ 280 frame)	n/a	o
221	Special cable entry direction	o	o
222	Lateral terminal box (dedicated housing for B_C motors)	o	o/s ⁽²⁾
304	Special voltage and/or frequency	o	o
312	Special cable entry	o	o
313	Brass cable glands	o	o
317	Additional nameplate for VFD	o	o
318	TAG plate	o	o
319	Additional Rating Nameplate	o	o
320	Nameplate with final customer logo	o	o
321	"Made in" Nameplate	o	o
325	Stainless steel screws	o	o
919	Non standard RAL paint colour	o	o
930	Special painting process for aggressive environments (F96819)	o	o
931	Special painting process for aggressive environments (F96826)	o	o
932	Special painting process for aggressive environments (F96827)	o	o

Key

s = standard

o = optional

n/a = not available

(2) Optional on 160-355 frame motors, standard on 355K motor models.

MECHANICAL TOLERANCES

Overall dimensions of the different motor frame sizes and types are indicated in the following pages, in mm. They are also valid for derived types. Some tolerances, in accordance with IEC 60072-1, are indicated in the following table.

The second shaft extension is built only on request.

Part	Dimension	Tolerance
Shaft extension	D-DA	from 11 to 28 mm diameter j6 /38 to 48 mm diameter k6 /55 to 100 mm diameter m6
Key	F-FA	h9
Flange concentricity	N	up to frame size 280 j6 / greater than js6
Shaft height	H	up to frame size 315 - 0,5 mm / greater than - 1 mm

TAPPED HOLES IN THE SHAFT EXTENSION

There is a threaded hole on the drive end side, with the shape and dimensions according to DIN332-2 and to the following table and figure (dimensions in mm).

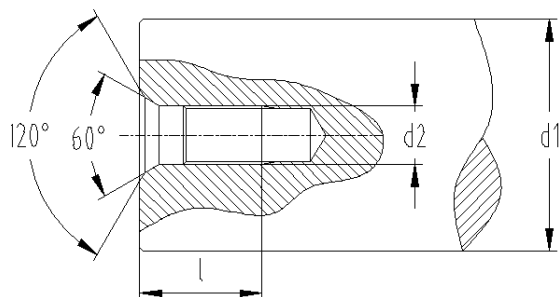

d1		d2	l
>	≤		+2/0
10	13	M4	10
13	16	M5	12,5
16	21	M6	16
21	24	M8	19
24	30	M10	22
30	38	M12	28
38	50	M16	36
50	85	M20	42
85	130	M24	50

A1C - 400 V - 50 Hz - ALUMINIUM - IE1

A1C - 400 V - 50 Hz - ALUMINIUM													IE1
Motor type	Rated Output	Rated Speed	Efficiency			Power factor	Current	Starting current	Rated torque	Starting torque	Breakdown torque	Moment of Inertia	Weight
			η %			$\cos\phi$	I_n	I_s/I_n	T_n	T_s/T_n	T_{max}/T_n	J	
	kW	rpm	100%	75%	50%		A	p.u.	Nm	p.u.	p.u.	kgm ²	kg
2 POLES													
A1C 63 MA2	0,18	2720	52,8	51,9	49,0	0,80	0,6	5,5	0,63	2,2	2,4	0,0002	5,4
A1C 63 MB2	0,25	2720	58,2	58,2	54,2	0,80	0,8	5,5	0,88	2,2	2,4	0,0002	5,7
A1C 63 MC2	0,37	2700	63,9	63,4	60,9	0,81	1,0	5,5	1,31	2,2	2,4	0,0002	5,9
A1C 71 MA2	0,37	2745	63,9	63,9	60,9	0,81	1,0	6,1	1,29	2,2	2,4	0,0003	6,2
A1C 71 MB2	0,55	2745	69,0	69,0	66,2	0,81	1,4	6,1	1,91	2,2	2,4	0,0005	7
A1C 71 MC2	0,75	2745	72,1	71,7	69,0	0,81	1,9	6,1	2,61	2,3	2,4	0,0003	7,4
A1C 80 MA2	0,75	2830	75,0	75,0	72,8	0,82	1,8	6,8	2,53	2,3	2,3	0,0008	8
A1C 80 MB2	1,1	2830	76,2	76,2	74,7	0,83	2,5	7,1	3,71	2,3	2,3	0,0010	9,1
A1C 80 MC2	1,5	2830	77,2	77,0	76,3	0,83	3,4	6,8	5,06	2,2	2,3	0,0010	10,1
A1C 90 S2	1,5	2840	78,5	78,5	77,3	0,84	3,3	7,3	5,04	2,3	2,3	0,0015	13
A1C 90 L2	2,2	2840	81,0	81,0	80,7	0,85	4,6	7,6	7,40	2,3	2,3	0,0021	14
A1C 90 LB2	3,0	2840	81,5	81,3	80,0	0,84	6,3	7,3	10,09	2,3	2,3	0,0023	16
A1C 100 LA2	3,0	2870	82,6	82,6	81,1	0,87	6,0	7,8	9,98	2,2	2,3	0,0032	20
A1C 100 LB2	4,0	2870	83,1	83,0	81,9	0,86	8,1	6,8	13,3	2,2	2,3	0,0045	22
A1C 112 M2	4,0	2890	84,2	84,2	83,9	0,88	7,8	8,1	13,2	2,2	2,3	0,0058	25
A1C 112 MB2	5,5	2890	84,7	84,5	83,8	0,88	11	7,8	18,2	2,2	2,3	0,0076	28
A1C 132 SA2	5,5	2900	85,7	85,7	85,0	0,88	11	8,2	18,1	2,2	2,3	0,0101	35
A1C 132 SB2	7,5	2900	87,0	87,0	87,3	0,89	14	7,8	24,7	2,2	2,3	0,0122	39
A1C 132 MA2	9,2	2900	87,0	86,8	85,7	0,89	17	8,2	30,3	2,2	2,3	0,0155	42
A1C 132 MB2	11,0	2900	87,6	87,4	86,3	0,89	20	7,8	36,2	2,2	2,3	0,0169	44
A1C 132 MC2	15,0	2920	88,7	88,4	86,8	0,90	27	7,9	49,1	2,3	2,9	0,0023	56
A1C 160 MA2	11,0	2930	88,4	88,4	87,4	0,89	20	7,9	35,9	2,2	2,3	0,0359	72
A1C 160 MB2	15,0	2930	89,4	89,4	87,6	0,89	27	7,9	48,9	2,2	2,3	0,0434	79
A1C 160 L2	18,5	2930	90,0	90,0	88,9	0,89	33	8,0	60,3	2,2	2,3	0,0548	91
A1C 180 M2	22,0	2940	90,5	90,1	88,4	0,89	39	8,1	71,5	2,2	2,3	0,0802	114
4 POLES													
A1C 63 MA4	0,12	1335	57,0	56,0	53,9	0,72	0,4	4,4	0,86	2,1	2,2	0,0004	5,3
A1C 63 MB4	0,18	1335	60,0	59,1	56,2	0,73	0,6	4,4	1,29	2,1	2,2	0,0004	5,8
A1C 63 MC4	0,25	1325	61,5	60,6	57,7	0,74	0,8	4,4	1,80	2,1	2,2	0,0005	6,2
A1C 71 MA4	0,25	1340	65,0	64,4	61,6	0,74	0,8	5,2	1,78	2,1	2,2	0,0007	7,2
A1C 71 MB4	0,37	1340	67,0	66,5	63,6	0,75	1,1	5,2	2,64	2,1	2,2	0,0008	7,8
A1C 71 MC4	0,55	1330	70,0	69,8	67,1	0,75	1,5	5,2	3,95	2,1	2,2	0,0009	8
A1C 80 MA4	0,55	1390	71,0	70,8	68,1	0,75	1,5	5,2	3,78	2,2	2,4	0,0013	8
A1C 80 MB4	0,75	1390	73,0	72,9	70,7	0,76	2,0	6,0	5,15	2,2	2,4	0,0015	9

A1C - 400 V - 50 Hz - ALUMINIUM

IE1

Motor type	Rated Output	Rated Speed	Efficiency			Power factor	Current	Starting current	Rated torque	Starting torque	Breakdown torque	Moment of Inertia	Weight
			η %			cosφ	I _n	I _s /I _n	T _n	T _s /T _n	T _{max} /T _n	J	
	kW	rpm	100%	75%	50%		A	p.u.	Nm	p.u.	p.u.	kgm ²	kg
4 POLES													
A1C 80 MC4	1,1	1390	75,2	75,0	73,9	0,76	2,8	5,2	7,56	2,2	2,4	0,0018	10,1
A1C 90 S4	1,1	1400	76,2	77,2	75,6	0,77	2,7	6,0	7,50	2,3	2,3	0,0023	12
A1C 90 L4	1,5	1400	78,5	79,5	78,9	0,78	3,5	6,0	10,23	2,3	2,3	0,0028	13
A1C 90 LB4	2,2	1400	79,7	79,5	78,2	0,76	5,2	6,0	15,0	2,3	2,3	0,0039	13
A1C 100 LA4	2,2	1430	81,0	81,2	79,7	0,80	4,9	7,0	14,7	2,3	2,4	0,0058	19
A1C 100 LB4	3,0	1430	82,6	82,8	81,5	0,81	6,5	7,0	20,0	2,3	2,4	0,0076	22
A1C 100 LC4	4,0	1430	83,1	82,8	81,7	0,77	9,0	7,0	26,7	2,3	2,4	0,0096	24
A1C 112 M4	4,0	1440	84,2	84,7	84,4	0,81	8,5	7,0	26,5	2,3	2,5	0,0126	28
A1C 112 MB4	5,5	1440	84,7	84,6	83,8	0,79	12	7,0	36,5	2,3	2,3	0,0190	30
A1C 132 S4	5,5	1440	85,7	86,3	85,9	0,83	11	7,0	36,5	2,0	2,3	0,0268	40
A1C 132 MA4	7,5	1440	87,0	87,5	86,9	0,83	15	7,0	49,7	2,0	2,3	0,0345	49
A1C 132 MB4	9,2	1440	87,0	86,8	85,5	0,82	19	7,0	61	2,3	2,4	0,0408	52
A1C 132 MC4	11,0	1440	87,6	87,5	86,3	0,82	22	7,0	73	2,3	2,4	0,0490	54
A1C 160 M4	11,0	1470	88,4	88,5	87,5	0,85	21	7,7	71	2,2	2,3	0,0748	76
A1C 160 L4	15,0	1470	89,4	89,5	88,7	0,86	28	7,8	97	2,2	2,3	0,1028	94
A1C 180 M4	18,5	1475	90,0	90,2	89,5	0,86	34	7,8	120	2,0	2,3	0,1460	118
A1C 180 L4	22,0	1475	90,5	90,6	89,9	0,86	41	7,8	142	2,0	2,3	0,1642	130
6 POLES													
A1C 71 MA6	0,18	855	56,0	56,1	51,9	0,66	0,7	4,0	2,01	1,9	2,0	0,0011	6,5
A1C 71 MB6	0,25	855	59,0	60,2	57,9	0,68	0,9	4,0	2,79	1,9	2,0	0,0013	7,4
A1C 71 MC6	0,37	855	61,1	61,7	58,4	0,68	1,3	4,0	4,13	1,9	2,0	0,0013	7,7
A1C 80 MA6	0,37	885	62,0	62,2	59,3	0,70	1,2	4,7	3,99	1,9	2,1	0,0018	8
A1C 80 MB6	0,55	885	65,0	65,7	63,4	0,72	1,7	4,7	5,94	1,9	2,1	0,0023	9
A1C 80 MC6	0,75	885	70,2	69,9	68,0	0,71	2,2	4,7	8,09	1,9	2,1	0,0027	10,1
A1C 90 S6	0,75	910	69,0	69,3	66,2	0,72	2,2	5,8	7,87	2,0	2,1	0,0033	12
A1C 90 L6	1,1	910	72,0	71,7	69,0	0,73	3,0	5,9	11,5	2,0	2,1	0,0041	14
A1C 100 LA6	1,5	920	76,0	76,3	74,2	0,75	3,8	5,9	15,6	2,0	2,1	0,0075	18
A1C 112 M6	2,2	940	79,0	79,7	78,5	0,76	5,3	6,2	22,4	2,0	2,1	0,0147	25
A1C 132 SA6	3,0	960	81,0	81,8	80,8	0,76	7,0	6,4	29,8	2,0	2,1	0,0286	35
A1C 132 MA6	4,0	960	82,0	82,9	82,2	0,76	9,3	6,6	39,8	2,0	2,1	0,0376	42
A1C 132 MB6	5,5	960	84,0	84,8	84,3	0,77	12	6,8	55	2,0	2,1	0,0519	51
A1C 160 M6	7,5	970	86,0	86,2	85,1	0,77	16	6,8	74	2,1	2,3	0,0862	72
A1C 160 L6	11,0	970	87,5	87,6	86,5	0,78	23	6,9	108	2,1	2,3	0,1292	90
A1C 180 L6	15,0	970	89,0	89,3	88,5	0,81	30	7,3	148	2,1	2,3	0,2174	120

A1C - 400 V - 50 Hz - ALUMINIUM

IE1

Motor type	Rated Output	Rated Speed	Efficiency			Power factor	Current	Starting current	Rated torque	Starting torque	Breakdown torque	Moment of Inertia	Weight
			η %			cosφ	I _n	I _s /I _n	T _n	T _s /T _n	T _{max} /T _n	J	
	kW	rpm	100%	75%	50%		A	p.u.	Nm	p.u.	p.u.	kgm ²	kg
8 POLES													
A1C 80 MA8	0,18	630	45,5	45,7	41,6	0,61	0,9	3,3	2,73	1,8	1,9	0,0019	9
A1C 80 MB8	0,25	640	50,3	50,5	46,2	0,61	1,2	3,3	3,73	1,8	1,9	0,0023	10
A1C 90 S8	0,37	660	55,9	55,3	53,4	0,66	1,4	4,0	5,35	1,8	1,9	0,0035	12
A1C 90 L8	0,55	660	60,9	60,3	58,4	0,65	2,0	4,0	7,96	1,8	2,0	0,0041	14
A1C 100 LA8	0,75	690	66,0	65,1	64,0	0,67	2,4	4,0	10,38	1,8	2,0	0,0057	15
A1C 100 LB8	1,1	690	70,2	69,9	68,0	0,69	3,3	5,0	15,2	1,8	2,0	0,0085	19
A1C 112 M8	1,5	690	74,0	73,2	71,3	0,68	4,3	5,0	20,8	1,8	2,0	0,0139	24
A1C 132 S8	2,2	710	75,0	75,5	72,5	0,71	6,0	6,0	29,6	1,8	2,0	0,0304	35
A1C 132 MA8	3,0	710	77,0	77,9	75,0	0,73	7,7	6,0	40,4	1,8	2,0	0,0412	43
A1C 160 MA8	4,0	720	80,0	79,1	77,5	0,73	9,9	6,0	53	1,9	2,1	0,0627	60
A1C 160 MB8	5,5	720	82,4	81,5	79,7	0,74	13	6,0	73	1,9	2,1	0,0862	71
A1C 160 L8	7,5	720	84,7	83,8	81,5	0,75	17	6,0	99	1,9	2,1	0,1175	87
A1C 180 L8	11,0	730	85,2	85,0	82,1	0,74	25	6,5	144	2,0	2,3	0,2042	118

B1C - 400 V - 50 Hz - CAST IRON - IE1

B1C - 400 V - 50 Hz - CAST IRON													IE1
Motor type	Rated Output	Rated Speed	Efficiency			Power factor	Current	Starting current	Rated torque	Starting torque	Breakdown torque	Moment of Inertia	Weight
			η %			$\cos\phi$	I_n	I_s/I_n	T_n	T_s/T_n	T_{max}/T_n	J	
	kW	rpm	100%	75%	50%		A	p.u.	Nm	p.u.	p.u.	kgm ²	kg
2 POLES													
B1C 63 MA2	0,18	2720	52,8	51,9	49,0	0,80	0,6	5,5	0,63	2,2	2,4	0,0002	7,6
B1C 63 MB2	0,25	2720	58,2	57,7	54,2	0,80	0,8	5,5	0,88	2,2	2,4	0,0002	8,5
B1C 71 MA2	0,37	2745	63,9	63,4	60,9	0,81	1,0	6,1	1,29	2,2	2,4	0,0003	9,3
B1C 71 MB2	0,55	2745	69,0	68,7	66,2	0,81	1,4	6,1	1,91	2,2	2,4	0,0005	10
B1C 80 MA2	0,75	2830	75,0	74,6	72,8	0,82	1,8	6,8	2,53	2,3	2,3	0,0008	15
B1C 80 MB2	1,1	2830	76,2	76,5	74,7	0,83	2,5	7,1	3,71	2,3	2,3	0,0010	16
B1C 90 S2	1,5	2840	78,5	78,9	77,3	0,84	3,3	7,3	5,04	2,3	2,3	0,0015	21
B1C 90 L2	2,2	2840	81,0	81,7	80,7	0,85	4,6	7,6	7,40	2,3	2,3	0,0021	24
B1C 100 LA2	3,0	2870	82,6	82,7	81,1	0,87	6,0	7,8	9,98	2,2	2,3	0,0032	31
B1C 112 M2	4,0	2890	84,2	84,7	83,9	0,88	7,8	8,1	13,2	2,2	2,3	0,0058	40
B1C 132 SA2	5,5	2900	85,7	86,0	85,0	0,88	10,5	8,2	18,1	2,2	2,3	0,0101	56
B1C 132 SB2	7,5	2900	87,0	87,7	87,3	0,89	14	7,8	24,7	2,2	2,3	0,0122	60
B1C 160 MA2	11,0	2930	88,4	87,8	87,4	0,89	20	7,9	35,9	2,2	2,3	0,0359	107
B1C 160 MB2	15,0	2930	89,4	89,1	87,6	0,89	27	7,9	48,9	2,2	2,3	0,0434	114
B1C 160 L2	18,5	2930	90,0	89,9	88,9	0,89	33	8,0	60	2,2	2,3	0,0548	130
B1C 180 M2	22,0	2940	90,5	90,1	88,4	0,89	39	8,1	71	2,2	2,3	0,0802	162
B1C 200 LA2	30,0	2950	91,4	91,1	89,8	0,89	53	7,5	97	2,0	2,3	0,1460	232
B1C 200 LB2	37,0	2950	92,0	91,8	90,7	0,89	65	7,5	120	2,0	2,3	0,1779	251
B1C 225 M2	45,0	2970	92,5	92,2	91,0	0,89	79	7,5	145	2,2	2,3	0,2177	281
B1C 250 M2	55,0	2970	93,0	92,6	91,3	0,89	96	7,6	177	2,2	2,3	0,3251	379
B1C 280 S2	75,0	2970	93,6	93,1	91,7	0,89	130	6,9	241	1,8	2,3	0,5205	477
B1C 280 M2	90,0	2970	93,9	93,5	92,3	0,89	155	6,9	289	1,8	2,3	0,6310	530
B1C 315 S2	110,0	2980	94,0	93,5	92,2	0,90	188	7,0	353	1,8	2,2	1,2692	762
B1C 315 MA2	132,0	2980	94,5	94,1	93,0	0,90	224	7,0	423	1,8	2,2	1,4505	871
B1C 315 MB2	160,0	2980	94,6	94,1	92,8	0,91	268	7,1	513	1,8	2,2	1,8131	958
B1C 315 MC2	200,0	2980	95,0	94,6	93,5	0,91	334	7,1	641	1,8	2,2	2,357	1088
B1C 355 M2	250,0	2980	95,0	94,7	93,6	0,91	417	7,1	801	1,6	2,2	3,2418	1572
B1C 355 LA2	315,0	2980	95,0	94,7	93,6	0,91	526	7,2	1009	1,6	2,2	4,2655	1789
B1C 355 KB2	355,0	2980	95,0	94,7	93,6	0,91	593	7,2	1138	1,6	2,2	6,2231	2200
B1C 355 KC2	400,0	2980	95,0	94,7	93,6	0,90	675	7,0	1282	1,6	2,2	7,4677	2300
B1C 355 KD2	450,0	2980	95,0	94,7	93,6	0,90	760	7,0	1442	1,6	2,2	8,0901	2350

B1C - 400 V - 50 Hz - CAST IRON

IE1

Motor type	Rated Output	Rated Speed	Efficiency			Power factor	Current	Starting current	Rated torque	Starting torque	Breakdown torque	Moment of Inertia	Weight
			η %			cosφ	I _n	I _s /I _n	T _n	T _s /T _n	T _{max} /T _n	J	
	kW	rpm	100%	75%	50%		A	p.u.	Nm	p.u.	p.u.	kgm ²	kg
4 POLES													
B1C 63 MA4	0,12	1335	57,0	56,0	53,9	0,72	0,4	4,4	0,86	2,1	2,2	0,0004	7,3
B1C 63 MB4	0,18	1335	60,0	59,1	56,2	0,73	0,6	4,4	1,29	2,1	2,2	0,0004	8,2
B1C 71 MA4	0,25	1340	65,0	64,4	61,6	0,74	0,8	5,2	1,78	2,1	2,2	0,0007	9
B1C 71 MB4	0,37	1340	67,0	66,5	63,6	0,75	1,1	5,2	2,64	2,1	2,2	0,0008	9,8
B1C 80 MA4	0,55	1390	71,0	70,8	68,1	0,75	1,5	5,2	3,78	2,2	2,4	0,0013	15
B1C 80 MB4	0,75	1390	73,0	72,9	70,7	0,76	2,0	6,0	5,15	2,2	2,4	0,0015	16
B1C 90 S4	1,1	1400	76,2	77,2	75,6	0,77	2,7	6,0	7,5	2,3	2,3	0,0023	21
B1C 90 L4	1,5	1400	78,5	79,5	78,9	0,78	3,5	6,0	10,23	2,3	2,3	0,0028	23
B1C 100 LA4	2,2	1430	81,0	81,2	79,7	0,80	4,9	7,0	14,7	2,3	2,4	0,0058	31
B1C 100 LB4	3,0	1430	82,6	82,8	81,5	0,81	6,5	7,0	20	2,3	2,4	0,0076	34
B1C 112 M4	4,0	1440	84,2	84,7	84,4	0,81	8,5	7,0	26,5	2,3	2,5	0,0126	43
B1C 132 S4	5,5	1440	85,7	86,3	85,9	0,83	11	7,0	36,5	2,0	2,3	0,0268	61
B1C 132 MA4	7,5	1440	87,0	87,5	86,9	0,83	15	7,0	49,7	2,0	2,3	0,0345	71
B1C 160 M4	11,0	1470	88,4	88,5	87,5	0,85	21	7,7	71	2,2	2,3	0,0748	112
B1C 160 L4	15,0	1470	89,4	89,5	88,7	0,86	28	7,8	97	2,2	2,3	0,1028	134
B1C 180 M4	18,5	1475	90,0	90,2	89,5	0,86	34	7,8	120	2,0	2,3	0,1460	163
B1C 180 L4	22,0	1475	90,5	90,6	89,9	0,86	41	7,8	142	2,0	2,3	0,1642	178
B1C 200 L4	30,0	1475	91,4	91,6	91,1	0,86	55	7,3	194	2,0	2,3	0,2612	237
B1C 225 S4	37,0	1480	92,0	91,9	90,9	0,86	67	7,4	239	2,0	2,3	0,4570	284
B1C 225 M4	45,0	1480	92,5	92,3	91,2	0,86	82	7,4	290	2,0	2,3	0,5511	313
B1C 250 M4	55,0	1485	93,0	92,9	92,0	0,86	99	7,4	354	2,2	2,3	0,6478	389
B1C 280 S4	75,0	1485	93,6	93,4	92,4	0,88	131	6,9	482	2,0	2,3	1,1785	503
B1C 280 M4	90,0	1485	93,9	93,7	92,8	0,88	157	6,9	579	2,0	2,3	1,3900	556
B1C 315 S4	110,0	1490	94,5	94,2	93,2	0,89	189	7,0	705	2,0	2,2	2,5752	778
B1C 315 MA4	132,0	1490	94,8	94,7	93,9	0,89	226	7,0	846	2,0	2,2	2,9111	892
B1C 315 MB4	160,0	1490	94,9	94,9	94,2	0,89	273	7,1	1026	2,0	2,2	3,5829	973
B1C 315 MC4	200,0	1490	95,2	95,1	94,2	0,90	337	7,1	1282	2,0	2,2	4,7026	1111
B1C 355 M4	250,0	1490	95,2	95,1	94,2	0,90	421	7,1	1602	2,0	2,2	7,8314	1599
B1C 355 LA4	315,0	1490	95,1	95,0	94,1	0,90	531	7,1	2019	2,0	2,2	9,5504	1750
B1C 355 LB4	355,0	1490	95,1	95,0	94,1	0,88	612	7,0	2275	2,0	2,2	11,0785	1882
B1C 355 KC4	400,0	1490	95,1	95,0	94,1	0,88	690	7,0	2564	2,0	2,2	12,6605	2350
B1C 355 KD4	450,0	1490	95,1	95,0	94,1	0,88	776	7,0	2884	2,0	2,2	13,3771	2400

BIC - 400 V - 50 Hz - CAST IRON

IE1

Motor type	Rated Output	Rated Speed	Efficiency			Power factor	Current	Starting current	Rated torque	Starting torque	Breakdown torque	Moment of Inertia	Weight
			η %			cosφ	I _n	I _s /I _n	T _n	T _s /T _n	T _{max} /T _n	J	
	kW	rpm	100%	75%	50%		A	p.u.	Nm	p.u.	p.u.	kgm ²	kg
6 POLES													
BIC 71 MA6	0,18	855	56,0	56,1	51,9	0,66	0,7	4,0	2,01	1,9	2,0	0,0011	6,8
BIC 71 MB6	0,25	855	59,0	60,2	57,9	0,68	0,9	4,0	2,79	1,9	2,0	0,0013	7,8
BIC 80 MA6	0,37	885	62,0	62,2	59,3	0,70	1,2	4,7	3,99	1,9	2,1	0,0018	15
BIC 80 MB6	0,55	885	65,0	65,7	63,4	0,72	1,7	4,7	5,94	1,9	2,1	0,0023	16
BIC 90 S6	0,75	910	69,0	69,3	66,2	0,72	2,2	5,8	7,87	2,0	2,1	0,0033	21
BIC 90 L6	1,1	910	72,0	71,7	69,0	0,73	3,0	5,9	11,5	2,0	2,1	0,0041	23
BIC 100 LA6	1,5	920	76,0	76,3	74,2	0,75	3,8	5,9	15,6	2,0	2,1	0,0075	30
BIC 112 M6	2,2	940	79,0	79,7	78,5	0,76	5,3	6,2	22,4	2,0	2,1	0,0147	40
BIC 132 S6	3,0	960	81,0	81,8	80,8	0,76	7,0	6,4	29,8	2,0	2,1	0,0286	55
BIC 132 MA6	4,0	960	82,0	82,9	82,2	0,76	9,3	6,6	39,8	2,0	2,1	0,0376	64
BIC 132 MB6	5,5	960	84,0	84,8	84,3	0,77	12	6,8	55	2,0	2,1	0,0519	73
BIC 160 M6	7,5	970	86,0	86,2	85,1	0,77	16	6,8	74	2,1	2,3	0,0862	107
BIC 160 L6	11,0	970	87,5	87,6	86,5	0,78	23	6,9	108	2,1	2,3	0,1292	131
BIC 180 L6	15,0	970	89,0	89,3	88,5	0,81	30	7,3	148	2,1	2,3	0,2174	169
BIC 200 LA6	18,5	970	90,0	90,3	89,6	0,81	37	7,2	182	2,1	2,3	0,3132	217
BIC 200 LB6	22,0	970	90,0	90,3	89,7	0,83	43	7,3	217	2,1	2,3	0,3654	232
BIC 225 M6	30,0	980	91,5	91,8	91,2	0,84	56	6,8	292	2,2	2,4	0,6137	292
BIC 250 M6	37,0	980	92,0	92,2	91,8	0,86	67	7,0	361	2,2	2,4	0,8368	366
BIC 280 S6	45,0	980	92,5	92,6	91,9	0,86	82	7,2	439	2,2	2,4	1,4151	470
BIC 280 M6	55,0	980	92,8	92,9	92,3	0,86	99	7,2	536	2,2	2,4	1,6649	518
BIC 315 S6	75,0	990	93,5	93,4	92,6	0,86	135	6,5	723	2,2	2,4	2,951	723
BIC 315 MA6	90,0	990	93,8	93,7	93,0	0,86	161	6,6	868	2,2	2,4	3,6887	857
BIC 315 MB6	110,0	990	94,0	93,9	93,2	0,86	196	6,6	1061	2,2	2,4	4,574	933
BIC 315 MC6	132,0	990	94,2	94,0	93,6	0,87	232	6,6	1273	2,2	2,4	5,4593	1008
BIC 355 MA6	160,0	990	94,5	94,4	93,4	0,88	278	6,7	1543	2,1	2,4	7,6441	1439
BIC 355 MB6	200,0	990	94,5	94,4	93,7	0,88	347	6,8	1929	2,1	2,4	9,5551	1570
BIC 355 LA6	250,0	990	94,5	94,4	93,7	0,88	434	6,8	2412	2,1	2,4	11,9439	1731
BIC 355 KB6	315,0	990	94,5	94,4	93,7	0,88	547	6,8	3039	2,0	2,5	16,6774	2385
BIC 355 KC6	355,0	990	94,5	94,4	93,7	0,88	616	6,8	3424	2,0	2,5	18,4329	2465

B1C - 400 V - 50 Hz - CAST IRON

IE1

Motor type	Rated Output	Rated Speed	Efficiency			Power factor	Current	Starting current	Rated torque	Starting torque	Breakdown torque	Moment of Inertia	Weight
			η %			cosφ	I _n	I _s /I _n	T _n	T _s /T _n	T _{max} /T _n	J	
	kW	rpm	100%	75%	50%		A	p.u.	Nm	p.u.	p.u.	kgm ²	kg
8 POLES													
B1C 80 MA8	0,18	630	45,5	45,7	41,6	0,65	0,9	3,3	2,73	1,8	1,9	0,0019	16
B1C 80 MB8	0,25	640	50,3	50,5	46,2	0,65	1,1	3,3	3,73	1,8	1,9	0,0023	17
B1C 90 S8	0,37	660	55,9	55,3	53,4	0,66	1,4	4,0	5,35	1,8	1,9	0,0035	21
B1C 90 L8	0,55	660	60,9	60,3	58,4	0,66	2,0	4,0	7,96	1,8	2,0	0,0041	23
B1C 100 LA8	0,75	690	66,0	65,1	64,0	0,67	2,4	4,0	10,38	1,8	2,0	0,0057	27
B1C 100 LB8	1,1	690	70,2	69,9	68,0	0,69	3,3	5,0	15,2	1,8	2,0	0,0085	31
B1C 112 M8	1,5	690	74,0	73,2	71,3	0,70	4,2	5,0	20,8	1,8	2,0	0,0139	39
B1C 132 S8	2,2	710	75,0	75,5	72,5	0,71	6,0	6,0	29,6	1,8	2,0	0,0304	56
B1C 132 MA8	3,0	710	77,0	77,9	75,0	0,73	7,7	6,0	40,4	1,8	2,0	0,0412	66
B1C 160 MA8	4,0	720	80,0	79,1	77,5	0,73	9,9	6,0	53	1,9	2,1	0,0627	97
B1C 160 MB8	5,5	720	82,4	81,5	79,7	0,74	13	6,0	73	1,9	2,1	0,0862	108
B1C 160 L8	7,5	720	84,7	83,8	81,5	0,75	17	6,0	99	1,9	2,1	0,1175	127
B1C 180 L8	11,0	730	85,2	85,0	82,1	0,75	25	6,5	144	2,0	2,3	0,2042	166
B1C 200 L8	15,0	730	86,2	85,8	84,5	0,76	33	6,5	196	2,0	2,3	0,3132	217
B1C 225 S8	18,5	730	86,9	87,0	85,5	0,76	40	6,5	242	1,9	2,1	0,4773	259
B1C 225 M8	22,0	740	87,4	87,4	86,6	0,78	47	6,5	284	1,9	2,1	0,5455	278
B1C 250 M8	30,0	740	88,3	88,3	87,2	0,79	62	6,5	387	1,9	2,1	0,8861	373
B1C 280 S8	37,0	740	88,8	88,6	87,9	0,79	76	6,6	478	1,9	2,1	1,5400	484
B1C 280 M8	45,0	740	89,2	89,3	88,2	0,79	92	6,6	581	1,9	2,1	1,8313	536
B1C 315 S8	55,0	740	89,7	89,9	88,8	0,81	109	6,4	710	1,8	2,0	3,4522	721
B1C 315 MA8	75,0	740	90,3	90,3	89,4	0,81	148	6,4	968	1,8	2,0	4,4016	865
B1C 315 MB8	90,0	740	90,7	90,7	89,8	0,82	175	6,3	1161	1,8	2,0	5,8688	972
B1C 315 MC8	110,0	740	91,1	91,2	90,3	0,82	213	6,3	1420	1,8	2,0	7,2497	1077
B1C 355 MA8	132,0	740	91,5	91,6	90,6	0,82	254	6,4	1704	1,8	2,0	11,1183	1518
B1C 355 MB8	160,0	740	91,9	92,0	91,0	0,82	306	6,4	2065	1,8	2,0	13,1664	1630
B1C 355 LA8	200,0	740	92,5	92,7	91,4	0,83	376	6,4	2581	1,8	2,0	16,6774	1819
B1C 355 KB8	250,0	740	92,5	92,7	91,4	0,83	470	6,5	3226	1,8	2,0	21,8452	2430
B1C 355 KC8	315,0	740	92,5	91,7	91,4	0,83	592	6,5	4065	1,8	2,0	26,2143	2500

B1C - 400 V - 50 Hz - CAST IRON

IE1

Motor type	Rated Output	Rated Speed	Efficiency			Power factor	Current	Starting current	Rated torque	Starting torque	Breakdown torque	Moment of Inertia	Weight
			η %			cosφ	I _n	I _s /I _n	T _n	T _s /T _n	T _{max} /T _n	J	
	kW	rpm	100%	75%	50%		A	p.u.	Nm	p.u.	p.u.	kgm ²	kg
10 POLES													
B1C 315 S10	55,0	590	92,0	90,9	88,8	0,75	115	5,5	890	1,5	2,0	4,8331	910
B1C 315 MA10	75,0	590	92,5	91,5	89,4	0,76	154	6,0	1214	1,6	2,2	6,4730	980
B1C 315 MB10	90,0	590	93,0	92,1	89,8	0,77	181	6,0	1456	1,6	2,2	7,5949	1060
B1C 355 MA10	110,0	590	93,2	92,2	90,0	0,78	218	6,2	1780	1,4	2,0	11,1183	1560
B1C 355 MB10	132,0	590	93,5	92,4	90,1	0,78	261	6,2	2136	1,4	2,0	13,3127	1670
B1C 355 MC10	160,0	590	93,5	92,4	90,1	0,78	317	6,2	2589	1,4	2,0	16,3848	1850
12 POLES													
B1C 315 S12	45,0	490	90,9	89,9	87,7	0,76	94	4,5	877	1,4	2,0	5,2612	930
B1C 315 MA12	55,0	490	91,8	90,7	88,6	0,76	114	4,5	1071	1,4	2,0	6,4766	1000
B1C 315 MB12	75,0	490	92,0	91,1	88,7	0,76	155	4,8	1461	1,5	2,0	8,9187	1150
B1C 355 MA12	90,0	490	92,1	91,0	89,0	0,75	188	5,5	1754	1,5	2,1	14,3547	1500
B1C 355 MB12	110,0	490	92,5	91,4	89,3	0,75	229	6,0	2143	1,6	2,1	16,3848	1680
B1C 355 MC12	132,0	490	92,8	91,9	89,7	0,75	274	6,0	2572	1,6	2,1	17,6971	1820

A2C - 400 V - 50 Hz - ALUMINIUM - IE2

A2C - 400 V - 50 Hz - ALUMINIUM													IE2
Motor type	Rated Output	Rated Speed	Efficiency			Power factor	Current	Starting current	Rated torque	Starting torque	Breakdown torque	Moment of Inertia	Weight
			η %			cosφ	I _n	I _s /I _n	T _n	T _s /T _n	T _{max} /T _n	J	
	kW	rpm	100%	75%	50%		A	p.u.	Nm	p.u.	p.u.	kgm ²	kg
2 POLES													
A2C 63 MA2	0,18	2720	60,4	61,6	60,2	0,80	0,5	3,8	0,63	2,0	2,4	0,0002	5,7
A2C 63 MB2	0,25	2720	64,8	65,2	64,1	0,80	0,7	4,0	0,88	2,0	2,4	0,0002	6
A2C 63 MC2	0,37	2720	69,5	69,5	66,8	0,80	1,0	4,0	1,30	2,0	2,4	0,0003	6,1
A2C 71 MA2	0,37	2745	69,5	70,0	69,0	0,81	0,9	4,1	1,29	2,0	2,3	0,0003	6,5
A2C 71 MB2	0,55	2745	74,1	74,0	71,3	0,81	1,3	4,5	1,91	2,0	2,3	0,0005	7
A2C 71 MC2	0,75	2745	77,4	77,0	73,8	0,81	1,7	4,5	2,61	2,0	2,3	0,0005	7,7
A2C 80 MA2	0,75	2830	77,4	77,0	73,8	0,82	1,7	6,8	2,53	2,3	2,3	0,0008	8
A2C 80 MB2	1,1	2830	79,6	79,9	78,1	0,83	2,4	7,1	3,71	2,3	2,3	0,0010	9
A2C 80 MC2	1,5	2830	81,3	81,2	79,1	0,83	3,2	7,1	5,06	2,3	2,3	0,0017	10,5
A2C 90 S2	1,5	2840	81,3	81,7	80,1	0,84	3,2	7,3	5,04	2,3	2,3	0,0015	13
A2C 90 L2	2,2	2840	83,2	83,9	82,9	0,85	4,5	7,3	7,40	2,3	2,3	0,0020	15
A2C 90 LB2	3,0	2840	84,6	84,3	82,6	0,85	6,0	7,3	10,09	2,3	2,3	0,0026	17
A2C 100 LA2	3,0	2870	84,6	84,7	83,1	0,87	5,9	7,4	9,98	2,2	2,3	0,0032	20
A2C 100 LB2	4,0	2870	85,8	85,6	83,8	0,87	7,7	7,4	13,3	2,2	2,3	0,0052	23
A2C 112 M2	4,0	2890	85,8	86,3	85,5	0,88	7,6	7,4	13,2	2,2	2,3	0,0076	28
A2C 112 MB2	5,5	2890	87,0	86,7	85,3	0,87	10,5	7,4	18,2	2,2	2,3	0,0076	29
A2C 132 SA2	5,5	2900	87,0	87,3	86,3	0,88	10,4	7,5	18,1	2,2	2,3	0,0115	37
A2C 132 SB2	7,5	2900	88,1	88,8	88,4	0,89	14	7,5	24,7	2,2	2,3	0,0135	41
A2C 132 MA2	9,2	2900	88,5	88,3	86,9	0,87	17	7,5	30,3	2,2	2,3	0,0176	44
A2C 132 MB2	11,0	2900	89,4	89,1	88,4	0,88	20	7,5	36,2	2,2	2,3	0,0181	46
A2C 160 MA2	11,0	2935	89,4	88,8	88,4	0,89	20	7,5	35,8	2,2	2,3	0,0416	74
A2C 160 MB2	15,0	2935	90,3	90,0	88,5	0,89	27	7,5	48,8	2,2	2,3	0,0510	83
A2C 160 L2	18,5	2935	90,9	90,8	89,8	0,89	33	7,5	60	2,2	2,3	0,0604	94
A2C 180 M2	22,0	2940	91,3	90,9	89,2	0,89	39	7,5	71	2,2	2,3	0,0857	120
4 POLES													
A2C 63 MA4	0,12	1335	59,1	58,8	55,5	0,72	0,4	4,4	0,86	2,1	2,2	0,0004	5,5
A2C 63 MB4	0,18	1335	64,7	64,9	61,8	0,73	0,6	4,4	1,29	2,1	2,2	0,0004	6
A2C 63 MC4	0,25	1335	68,5	68,4	65,1	0,72	0,7	4,4	1,79	2,1	2,2	0,0006	6,3
A2C 71 MA4	0,25	1340	68,5	68,5	65,1	0,74	0,7	5,2	1,78	2,1	2,2	0,0007	7,5
A2C 71 MB4	0,37	1340	72,7	72,6	69,7	0,75	1	5,2	2,64	2,1	2,2	0,0008	8
A2C 71 MC4	0,55	1340	77,1	77,0	74,8	0,74	1,4	5,2	3,92	2,1	2,2	0,0011	8,2
A2C 80 MA4	0,55	1390	77,1	77,0	74,8	0,75	1,4	5,2	3,78	2,2	2,4	0,0014	9,5
A2C 80 MB4	0,75	1390	79,6	79,5	77,3	0,76	1,8	6,0	5,15	2,2	2,4	0,0018	10
A2C 80 MC4	1,1	1390	81,4	81,3	80,4	0,76	2,6	5,2	7,56	2,2	2,4	0,0021	11

A2C - 400 V - 50 Hz - ALUMINIUM

IE2

Motor type	Rated Output	Rated Speed	Efficiency			Power factor	Current	Starting current	Rated torque	Starting torque	Breakdown torque	Moment of Inertia	Weight
			η %			cosφ	I _n	I _s /I _n	T _n	T _s /T _n	T _{max} /T _n	J	
	kW	rpm	100%	75%	50%		A	p.u.	Nm	p.u.	p.u.	kgm ²	kg
4 POLES													
A2C 90 S4	1,1	1400	81,4	82,4	80,8	0,77	2,5	6,0	7,50	2,3	2,3	0,0026	13
A2C 90 L4	1,5	1400	82,8	83,8	83,2	0,78	3,4	6,0	10,23	2,3	2,3	0,0031	14
A2C 90 LB4	2,2	1400	84,3	84,1	82,7	0,78	4,8	6,0	15,0	2,3	2,3	0,0045	14
A2C 100 LA4	2,2	1430	84,3	84,5	83,0	0,8	4,7	7,0	14,7	2,3	2,4	0,0069	20
A2C 100 LB4	3,0	1430	85,5	85,7	84,4	0,81	6,3	7,0	20,0	2,3	2,4	0,0089	24
A2C 100 LC4	4,0	1430	86,6	86,5	85,0	0,80	8,3	7,0	26,7	2,3	2,4	0,0131	25
A2C 112 M4	4,0	1440	86,6	87,1	86,8	0,81	8,2	7,0	26,5	2,3	2,5	0,0137	30
A2C 112 MB4	5,5	1440	87,7	87,7	86,0	0,81	11	7,0	36,5	2,3	2,5	0,0222	31
A2C 132 S4	5,5	1440	87,7	88,3	87,9	0,83	10,9	7,0	36,5	2,0	2,3	0,0294	43
A2C 132 MA4	7,5	1440	88,7	89,2	88,6	0,83	15	7,0	49,7	2,0	2,3	0,0370	51
A2C 132 MB4	9,2	1440	89,1	89,0	87,9	0,83	18	7,0	61	2,0	2,3	0,0472	53
A2C 132 MC4	11,0	1440	89,8	89,8	88,3	0,84	21	7,0	73	2,0	2,3	0,0561	55
A2C 160 M4	11,0	1470	89,8	89,9	88,9	0,85	21	7,7	71	2,2	2,3	0,0841	81
A2C 160 L4	15,0	1470	90,6	90,7	89,9	0,86	28	7,8	97	2,2	2,3	0,1091	97
A2C 180 M4	18,5	1475	91,2	91,4	90,7	0,86	34	7,8	120	2,0	2,3	0,1460	118
A2C 180 L4	22,0	1475	91,6	91,7	91,0	0,86	40	7,8	142	2,0	2,3	0,1642	128
6 POLES													
A2C 71 MA6	0,18	860	56,6	56,7	52,5	0,66	0,7	4,0	2,00	1,9	2,0	0,0011	7
A2C 71 MB6	0,25	860	61,6	61,9	59,1	0,68	0,9	4,0	2,78	1,9	2,0	0,0013	8
A2C 71 MC6	0,37	860	67,6	67,8	64,5	0,68	1,2	4,7	4,11	1,9	2,1	0,0017	7,9
A2C 80 MA6	0,37	880	67,6	68,0	64,5	0,70	1,1	4,7	4,02	1,9	2,1	0,0018	10
A2C 80 MB6	0,55	880	73,1	73,9	71,2	0,71	1,5	4,7	5,97	1,9	2,1	0,0023	11
A2C 80 MC6	0,75	880	75,9	76,0	73,1	0,70	2,0	4,7	8,14	1,9	2,1	0,0032	11
A2C 90 S6	0,75	910	75,9	76,2	73,1	0,71	2,0	5,8	7,87	2,0	2,1	0,0033	12
A2C 90 L6	1,1	910	78,1	77,8	75,1	0,72	2,8	5,9	11,5	2,0	2,1	0,0045	15
A2C 100 LA6	1,5	940	79,8	80,1	78,0	0,72	3,8	5,9	15,2	2,0	2,1	0,0080	19
A2C 112 M6	2,2	940	81,8	82,5	81,3	0,72	5,4	6,2	22,4	2,0	2,1	0,0147	25
A2C 132 S6	3,0	960	83,3	84,1	83,1	0,72	7,2	6,4	29,8	2,0	2,1	0,0286	35
A2C 132 MA6	4,0	960	84,6	85,5	84,8	0,74	9,2	6,6	39,8	2,0	2,1	0,0376	41
A2C 132 MB6	5,5	960	86,0	86,8	86,3	0,75	12	6,8	55	2,0	2,1	0,0537	51
A2C 160 M6	7,5	970	87,2	87,4	86,3	0,78	16	6,8	74	2,1	2,3	0,0862	72
A2C 160 L6	11,0	970	88,7	88,8	87,7	0,79	23	6,9	108	2,1	2,3	0,1292	91
A2C 180 L6	15,0	970	89,7	90,0	89,2	0,82	29	7,3	148	2,1	2,3	0,2174	120

A2C - 400 V - 50 Hz - ALUMINIUM

IE2

Motor type	Rated Output	Rated Speed	Efficiency			Power factor	Current	Starting current	Rated torque	Starting torque	Breakdown torque	Moment of Inertia	Weight
			η %			$\cos\phi$	I_n	I_s/I_n	T_n	T_s/T_n	T_{max}/T_n	J	
	kW	rpm	100%	75%	50%		A	p.u.	Nm	p.u.	p.u.	kgm ²	kg
8 POLES													
A2C 80 MA8	0,18	630	45,9	46,2	42,2	0,61	0,9	3,3	2,73	1,8	1,9	0,0019	9
A2C 80 MB8	0,25	640	50,6	50,8	46,5	0,62	1,2	3,3	3,73	1,8	1,9	0,0023	10
A2C 90 S8	0,37	660	56,1	57,2	55	0,63	1,5	4,0	5,35	1,8	1,9	0,0035	13
A2C 90 L8	0,55	660	61,7	61,8	57,5	0,65	2,0	4,0	7,96	1,8	2,0	0,0041	14
A2C 100 LA8	0,75	690	66,2	65,6	63,7	0,67	2,4	4,0	10,38	1,8	2,0	0,0057	15
A2C 100 LB8	1,1	690	70,8	70,5	68,6	0,69	3,3	5,0	15,2	1,8	2,0	0,0085	19
A2C 112 M8	1,5	690	74,1	73,3	71,4	0,70	4,2	5,0	20,8	1,8	2,0	0,0139	24
A2C 132 S8	2,2	710	77,6	77,0	75,9	0,71	5,8	6,0	29,6	1,8	2,0	0,0304	35
A2C 132 MA8	3,0	710	80,0	79,9	78,0	0,73	7,4	6,0	40,4	1,8	2,0	0,0412	43
A2C 160 MA8	4,0	720	81,9	81,9	79,2	0,73	9,7	6,0	53	1,9	2,1	0,0627	60
A2C 160 MB8	5,5	720	83,8	82,9	81,1	0,74	13	6,0	73	1,9	2,1	0,0862	71
A2C 160 L8	7,5	720	85,3	84,4	82,1	0,75	17	6,0	99	1,9	2,1	0,1175	87
A2C 180 L8	11,0	730	86,9	86,0	83,7	0,75	24	6,5	144	2,0	2,3	0,2042	118

B2C - 400 V - 50 Hz - ALUMINIUM - IE2

B2C - 400 V - 50 Hz - CAST IRON													IE2
Motor type	Rated Output	Rated Speed	Efficiency			Power factor	Current	Starting current	Rated torque	Starting torque	Breakdown torque	Moment of Inertia	Weight
			η %			cosφ	I _n	I _s /I _n	T _n	T _s /T _n	T _{max} /T _n	J	
	kW	rpm	100%	75%	50%		A	p.u.	Nm	p.u.	p.u.	kgm ²	kg
2 POLES													
B2C 63 MA2	0,18	2720	60,4	61,6	60,2	0,80	0,5	3,8	0,63	2,0	2,4	0,0002	7,6
B2C 63 MB2	0,25	2720	64,8	65,2	64,1	0,80	0,7	4,0	0,88	2,0	2,4	0,0002	8,5
B2C 71 MA2	0,37	2745	69,5	70,0	69,0	0,81	0,9	4,1	1,29	2,0	2,3	0,0003	9,3
B2C 71 MB2	0,55	2745	74,1	74,0	71,3	0,81	1,3	4,5	1,91	2,0	2,3	0,0005	10
B2C 80 MA2	0,75	2830	77,4	77,0	73,8	0,82	1,7	6,8	2,53	2,3	2,3	0,0008	15
B2C 80 MB2	1,1	2830	79,6	79,9	78,1	0,83	2,4	7,1	3,71	2,3	2,3	0,0010	16
B2C 90 S2	1,5	2840	81,3	81,7	80,1	0,84	3,2	7,3	5,04	2,3	2,3	0,0015	21
B2C 90 L2	2,2	2840	83,2	83,9	82,9	0,85	4,5	7,3	7,40	2,3	2,3	0,0020	24
B2C 100 LA2	3,0	2870	84,6	84,7	83,1	0,87	5,9	7,4	9,98	2,2	2,3	0,0032	31
B2C 112 M2	4,0	2890	85,8	86,3	85,5	0,88	7,6	7,4	13,2	2,2	2,3	0,0076	43
B2C 132 SA2	5,5	2900	87,0	87,3	86,3	0,88	10,4	7,5	18,1	2,2	2,3	0,0115	58
B2C 132 SB2	7,5	2900	88,1	88,8	88,4	0,89	14	7,5	24,7	2,2	2,3	0,0135	62
B2C 160 MA2	11,0	2935	89,4	88,8	88,4	0,89	20	7,5	35,8	2,2	2,3	0,0416	112
B2C 160 MB2	15,0	2935	90,3	90,0	88,5	0,89	27	7,5	48,8	2,2	2,3	0,0510	121
B2C 160 L2	18,5	2935	90,9	90,8	89,8	0,89	33	7,5	60	2,2	2,3	0,0604	136
B2C 180 M2	22,0	2940	91,3	90,9	89,2	0,89	39	7,5	71	2,2	2,3	0,0857	166
B2C 200 LA2	30,0	2950	92,0	91,7	90,4	0,89	53	7,5	97	2,0	2,3	0,1460	232
B2C 200 LB2	37,0	2950	92,5	92,3	91,2	0,89	65	7,5	120	2,0	2,3	0,1779	252
B2C 225 M2	45,0	2970	92,9	92,6	91,4	0,89	79	7,5	145	2,2	2,3	0,2322	286
B2C 250 M2	55,0	2970	93,2	92,8	91,5	0,89	96	7,6	177	2,2	2,3	0,3251	379
B2C 280 S2	75,0	2975	93,8	93,3	91,9	0,89	130	6,9	241	1,8	2,3	0,5205	477
B2C 280 M2	90,0	2975	94,1	93,7	92,5	0,89	155	6,9	289	1,8	2,3	0,6310	530
B2C 315 S2	110,0	2980	94,3	93,8	92,5	0,90	187	7,0	353	1,8	2,2	1,2692	762
B2C 315 MA2	132,0	2980	94,6	94,2	93,1	0,90	224	7,0	423	1,8	2,2	1,4505	871
B2C 315 MB2	160,0	2980	94,8	94,3	93,0	0,91	268	7,1	513	1,8	2,2	1,8131	961
B2C 315 MC2	200,0	2980	95,0	94,6	93,5	0,91	334	7,1	641	1,8	2,2	2,3570	1089
B2C 355 M2	250,0	2980	95,0	94,7	93,6	0,91	417	7,1	801	1,6	2,2	3,2418	1572
B2C 355 LA2	315,0	2980	95,0	94,7	93,6	0,91	526	7,2	1009	1,6	2,2	4,2655	1789
B2C 355 KB2	355,0	2980	95,0	94,7	93,6	0,91	593	7,2	1138	1,6	2,2	6,2231	2160
B2C 355 KC2	400,0	2980	95,0	94,7	93,6	0,90	675	7,0	1282	1,6	2,2	7,4677	2272
B2C 355 KD2	450,0	2980	95,0	94,7	93,6	0,90	760	7,0	1442	1,6	2,2	8,0901	2352

B2C - 400 V - 50 Hz - CAST IRON

IE2

Motor type	Rated Output	Rated Speed	Efficiency			Power factor	Current	Starting current	Rated torque	Starting torque	Breakdown torque	Moment of Inertia	Weight
			η %			cosφ	I _n	I _s /I _n	T _n	T _s /T _n	T _{max} /T _n	J	
	kW	rpm	100%	75%	50%		A	p.u.	Nm	p.u.	p.u.	kgm ²	kg
4 POLES													
B2C 63 MA4	0,12	1335	59,1	58,8	55,5	0,72	0,4	4,4	0,86	2,1	2,2	0,0004	7,6
B2C 63 MB4	0,18	1335	64,7	64,9	61,8	0,73	0,6	4,4	1,29	2,1	2,2	0,0004	8,5
B2C 71 MA4	0,25	1340	68,5	68,5	65,1	0,74	0,7	5,2	1,78	2,1	2,2	0,0007	9,3
B2C 71 MB4	0,37	1340	72,7	72,6	69,7	0,75	1,0	5,2	2,64	2,1	2,2	0,0008	10
B2C 80 MA4	0,55	1390	77,1	77,0	74,8	0,75	1,4	5,2	3,78	2,2	2,4	0,0014	14
B2C 80 MB4	0,75	1390	79,6	79,5	77,3	0,76	1,8	6,0	5,15	2,2	2,4	0,0018	17
B2C 90 S4	1,1	1400	81,4	82,4	80,8	0,77	2,5	6,0	7,50	2,3	2,3	0,0026	21
B2C 90 L4	1,5	1400	82,8	83,8	83,2	0,78	3,4	6,0	10,23	2,3	2,3	0,0031	24
B2C 100 LA4	2,2	1430	84,3	84,5	83,0	0,80	4,7	7,0	14,7	2,3	2,4	0,0069	32
B2C 100 LB4	3,0	1430	85,5	85,7	84,4	0,81	6,3	7,0	20,0	2,3	2,4	0,0089	36
B2C 112 M4	4,0	1440	86,6	87,1	86,8	0,81	8,2	7,0	26,5	2,3	2,5	0,0137	45
B2C 132 S4	5,5	1440	87,7	88,3	87,9	0,83	10,9	7,0	36,5	2,0	2,3	0,0294	63
B2C 132 MA4	7,5	1440	88,7	89,2	88,6	0,83	15	7,0	49,7	2,0	2,3	0,0370	73
B2C 160 M4	11,0	1470	89,8	89,9	88,9	0,85	21	7,7	71	2,2	2,3	0,0841	117
B2C 160 L4	15,0	1470	90,6	90,7	89,9	0,86	28	7,8	97	2,2	2,3	0,1091	137
B2C 180 M4	18,5	1475	91,2	91,4	90,7	0,86	34	7,8	120	2,0	2,3	0,1460	163
B2C 180 L4	22,0	1475	91,6	91,7	91,0	0,86	40	7,8	142	2,0	2,3	0,1642	177
B2C 200 L4	30,0	1475	92,3	92,5	92,0	0,86	55	7,3	194	2,0	2,3	0,2612	236
B2C 225 S4	37,0	1480	92,7	92,6	91,6	0,86	67	7,4	239	2,0	2,3	0,4570	284
B2C 225 M4	45,0	1480	93,1	92,9	91,8	0,86	81	7,4	290	2,0	2,3	0,5511	312
B2C 250 M4	55,0	1485	93,5	93,4	92,5	0,86	99	7,4	354	2,2	2,3	0,6478	387
B2C 280 S4	75,0	1485	94,0	93,8	92,8	0,88	131	6,9	482	2,0	2,3	1,1785	502
B2C 280 M4	90,0	1485	94,2	94,0	93,1	0,88	157	6,9	579	2,0	2,3	1,3900	555
B2C 315 S4	110,0	1490	94,5	94,2	93,2	0,89	189	7,0	705	2,0	2,2	2,5752	778
B2C 315 MA4	132,0	1490	94,7	94,6	93,8	0,89	226	7,0	846	2,0	2,2	2,9111	891
B2C 315 MB4	160,0	1490	94,9	94,9	94,2	0,89	273	7,1	1026	2,0	2,2	3,5829	973
B2C 315 MC4	200,0	1490	95,1	95,2	94,7	0,90	337	7,1	1282	2,0	2,2	4,7026	1111
B2C 355 M4	250,0	1490	95,1	95,0	94,1	0,90	422	7,1	1602	2,0	2,2	7,8314	1599
B2C 355 LA4	315,0	1490	95,1	95,0	94,1	0,90	531	7,1	2019	2,0	2,2	9,5504	1749
B2C 355 LB4	355,0	1490	95,1	95,0	94,1	0,88	612	7,0	2275	2,0	2,2	11,0785	1882
B2C 355 KC4	400,0	1490	95,1	95,0	94,1	0,88	690	7,0	2564	2,0	2,2	12,6610	2362
B2C 355 KD4	450,0	1490	95,1	95,0	94,1	0,88	776	7,0	2884	2,0	2,2	13,3770	2433

B2C - 400 V - 50 Hz - CAST IRON

IE2

Motor type	Rated Output	Rated Speed	Efficiency			Power factor	Current	Starting current	Rated torque	Starting torque	Breakdown torque	Moment of Inertia	Weight
			η %			cosφ	I _n	I _s /I _n	T _n	T _s /T _n	T _{max} /T _n	J	
	kW	rpm	100%	75%	50%		A	p.u.	Nm	p.u.	p.u.	kgm ²	kg
6 POLES													
B2C 71 MA6	0,18	860	56,6	56,7	52,5	0,66	0,7	4,0	2,00	1,9	2,0	0,0011	10
B2C 71 MB6	0,25	860	61,6	61,9	59,1	0,68	0,9	4,0	2,78	1,9	2,0	0,0013	11
B2C 80 MA6	0,37	880	67,6	68,0	64,5	0,70	1,1	4,7	4,02	1,9	2,1	0,0018	13
B2C 80 MB6	0,55	880	73,1	73,9	71,2	0,71	1,5	4,7	5,97	1,9	2,1	0,0023	15
B2C 90 S6	0,75	910	75,9	76,2	73,1	0,71	2,0	5,8	7,87	2,0	2,1	0,0033	21
B2C 90 L6	1,1	910	78,1	77,8	75,1	0,72	2,8	5,9	11,5	2,0	2,1	0,0045	24
B2C 100 LA6	1,5	940	79,8	80,1	78,0	0,72	3,8	5,9	15,2	2,0	2,1	0,0080	31
B2C 112 M6	2,2	940	81,8	82,5	81,3	0,72	5,4	6,2	22,4	2,0	2,1	0,0147	40
B2C 132 S6	3,0	960	83,3	84,1	83,1	0,72	7,2	6,4	29,8	2,0	2,1	0,0286	55
B2C 132 MA6	4,0	960	84,6	85,5	84,8	0,74	9,2	6,6	39,8	2,0	2,1	0,0376	63
B2C 132 MB6	5,5	960	86,0	86,8	86,3	0,75	12	6,8	55	2,0	2,1	0,0537	73
B2C 160 M6	7,5	970	87,2	87,4	86,3	0,78	16	6,8	74	2,1	2,3	0,0862	107
B2C 160 L6	11,0	970	88,7	88,8	87,7	0,79	23	6,9	108	2,1	2,3	0,1292	131
B2C 180 L6	15,0	970	89,7	90,0	89,2	0,82	29	7,3	148	2,1	2,3	0,2174	169
B2C 200 LA6	18,5	970	90,4	90,7	90,0	0,80	37	7,2	182	2,1	2,3	0,3132	217
B2C 200 LB6	22,0	970	90,9	91,2	90,6	0,81	43	7,3	217	2,1	2,3	0,3654	231
B2C 225 M6	30,0	980	91,7	92,0	91,4	0,82	58	6,8	292	2,2	2,4	0,6137	292
B2C 250 M6	37,0	980	92,2	92,4	92,0	0,83	70	7,0	361	2,2	2,4	0,8368	366
B2C 280 S6	45,0	980	92,7	92,8	92,1	0,85	82	7,2	439	2,2	2,4	1,4151	469
B2C 280 M6	55,0	980	93,1	93,2	92,6	0,86	99	7,2	536	2,2	2,4	1,6649	518
B2C 315 S6	75,0	990	93,7	93,6	92,8	0,84	138	6,5	723	2,2	2,4	2,9510	723
B2C 315 MA6	90,0	990	94,0	93,9	93,2	0,85	163	6,6	868	2,2	2,4	3,6887	857
B2C 315 MB6	110,0	990	94,3	94,2	93,5	0,85	198	6,6	1061	2,2	2,4	4,5740	933
B2C 315 MC6	132,0	990	94,6	94,4	94,0	0,86	234	6,6	1273	2,2	2,4	5,4593	1008
B2C 355 M6	160,0	990	94,8	94,7	93,7	0,86	283	6,7	1543	2,1	2,4	7,6441	1439
B2C 355 LA6	200,0	990	95,0	94,9	94,2	0,86	353	6,8	1929	2,1	2,4	9,5551	1570
B2C 355 LB6	250,0	990	95,0	94,9	94,2	0,86	442	6,8	2412	2,1	2,4	11,9439	1731
B2C 355 KB6	315,0	990	95,0	94,9	94,2	0,86	557	6,8	3039	2,0	2,5	16,6774	2393
B2C 355 KC6	355,0	990	95,0	94,9	94,2	0,86	627	6,8	3424	2,0	2,5	18,4329	2475

B2C - 400 V - 50 Hz - CAST IRON

IE2

Motor type	Rated Output	Rated Speed	Efficiency			Power factor	Current	Starting current	Rated torque	Starting torque	Breakdown torque	Moment of Inertia	Weight
			η %			cosφ	I _n	I _s /I _n	T _n	T _s /T _n	T _{max} /T _n	J	
	kW	rpm	100%	75%	50%		A	p.u.	Nm	p.u.	p.u.	kgm ²	kg
8 POLES													
B2C 80 MA8	0,18	630	45,9	46,2	42,2	0,61	0,9	3,3	2,73	1,8	1,9	0,0019	16
B2C 80 MB8	0,25	640	50,6	50,8	46,5	0,62	1,2	3,3	3,73	1,8	1,9	0,0023	17
B2C 90 S8	0,37	660	56,1	57,2	55,0	0,63	1,5	4,0	5,35	1,8	1,9	0,0035	21
B2C 90 L8	0,55	660	61,7	61,8	57,5	0,65	2,0	4,0	7,96	1,8	2,0	0,0041	23
B2C 100 LA8	0,75	690	66,2	65,6	63,7	0,67	2,4	4,0	10,38	1,8	2,0	0,0057	27
B2C 100 LB8	1,1	690	70,8	70,5	68,6	0,69	3,3	5,0	15,2	1,8	2,0	0,0085	31
B2C 112 M8	1,5	690	74,1	73,3	71,4	0,70	4,2	5,0	20,8	1,8	2,0	0,0139	39
B2C 132 S8	2,2	710	77,6	77,0	75,9	0,71	5,8	6,0	29,6	1,8	2,0	0,0304	56
B2C 132 MA8	3,0	710	80,0	79,9	78,0	0,73	7,4	6,0	40,4	1,8	2,0	0,0412	66
B2C 160 MA8	4,0	720	81,9	81,9	79,2	0,73	9,7	6,0	53	1,9	2,1	0,0627	97
B2C 160 MB8	5,5	720	83,8	82,9	81,1	0,74	13	6,0	73	1,9	2,1	0,0862	108
B2C 160 L8	7,5	720	85,3	84,4	82,1	0,75	17	6,0	99	1,9	2,1	0,1175	127
B2C 180 L8	11,0	730	86,9	86,0	83,7	0,75	24	6,5	144	2,0	2,3	0,2042	166
B2C 200 L8	15,0	730	88,0	87,3	85,0	0,76	32	6,5	196	2,0	2,3	0,3132	217
B2C 225 S8	18,5	730	88,6	87,5	85,4	0,76	40	6,5	242	1,9	2,1	0,4773	259
B2C 225 M8	22,0	740	89,1	88,0	86,2	0,78	46	6,5	284	1,9	2,1	0,5455	278
B2C 250 M8	30,0	740	89,8	88,9	87,1	0,79	61	6,5	387	1,9	2,1	0,8861	373
B2C 280 S8	37,0	740	90,3	89,4	87,9	0,79	75	6,6	478	1,9	2,1	1,5400	484
B2C 280 M8	45,0	740	90,7	89,9	88,6	0,79	91	6,6	581	1,9	2,1	1,8313	536
B2C 315 S8	55,0	740	91,0	90,1	88,9	0,81	108	6,4	710	1,8	2,0	3,4522	721
B2C 315 MA8	75,0	740	91,6	90,5	89,4	0,81	146	6,4	968	1,8	2,0	4,4016	865
B2C 315 MB8	90,0	740	91,9	90,8	89,8	0,82	172	6,3	1161	1,8	2,0	5,8688	972
B2C 315 MC8	110,0	740	92,3	91,4	90,3	0,82	210	6,3	1420	1,8	2,0	7,2497	1077
B2C 355 MA8	132,0	740	92,6	91,2	90,1	0,82	251	6,4	1704	1,8	2,0	11,1183	1518
B2C 355 MB8	160,0	740	93,0	92,3	91,2	0,82	303	6,4	2065	1,8	2,0	13,1664	1630
B2C 355 LA8	200,0	740	93,5	92,9	91,9	0,83	372	6,4	2581	1,8	2,0	16,6774	1819
B2C 355 KB8	250,0	740	93,5	92,9	91,9	0,83	465	6,5	3226	1,8	2,0	21,8452	2430
B2C 355 KC8	315,0	740	93,5	92,9	91,9	0,83	586	6,5	4065	1,8	2,0	26,2143	2500

A3C - 400 V - 50 Hz - ALUMINIUM - IE3

A3C - 400 V - 50 Hz - ALUMINIUM												IE3	
Motor type	Rated Output	Rated Speed	Efficiency			Power factor	Current	Starting current	Rated torque	Starting torque	Breakdown torque	Moment of Inertia	Weight
			η %			$\cos\phi$	I_n	I_s/I_n	T_n	T_s/T_n	T_{max}/T_n	J	
	kW	rpm	100%	75%	50%		A	p.u.	Nm	p.u.	p.u.	kgm ²	kg
2 POLES													
A3C 80 MA2	0,75	2910	80,7	80,9	79,0	0,82	1,6	7,0	2,50	2,3	2,5	0,0010	9
A3C 80 MB2	1,1	2910	82,7	83,2	82,5	0,83	2,3	7,3	3,70	2,2	2,5	0,0020	11
A3C 80 MC2	1,5	2880	84,2	83,9	82,5	0,84	3,1	6,7	4,97	2,4	2,7	0,0016	13
A3C 90 S2	1,5	2910	84,2	84,6	83,6	0,84	3,1	7,6	5,00	2,2	2,5	0,0020	14
A3C 90 L2	2,2	2910	85,9	86,3	84,8	0,85	4,3	7,6	7,30	2,2	2,5	0,0030	16
A3C 90 LB2	3,0	2885	87,1	86,9	85,6	0,86	5,8	7,1	9,93	2,4	2,6	0,0031	18
A3C 100 LA2	3,0	2910	87,1	87,9	87,4	0,87	5,7	7,8	9,90	2,2	2,5	0,0060	23
A3C 100 LB2	4,0	2900	88,1	88,0	86,7	0,88	7,4	7,9	13,2	2,5	2,8	0,0054	25
A3C 112 M2	4,0	2915	88,1	89,8	90,7	0,88	7,4	8,3	13,2	2,2	2,5	0,0090	26
A3C 112 MB2	5,5	2900	89,2	89,1	88,7	0,89	10	7,5	18,1	2,4	2,9	0,0086	33
A3C 132 SA2	5,5	2920	89,2	89,7	89,0	0,88	10,1	8,3	18,1	2,0	2,5	0,0240	41
A3C 132 SB2	7,5	2920	90,1	90,9	90,9	0,88	14	7,9	24,7	2,0	2,5	0,0290	46
A3C 132 MA2	9,2	2935	90,6	90,5	89,1	0,89	16	7,9	29,9	2,4	3,0	0,0189	48
A3C 132 MB2	11,0	2935	91,2	91,0	90,2	0,89	20	7,8	35,8	2,5	3,0	0,0216	52
A3C 160 MA2	11,0	2935	91,2	91,4	88,9	0,89	20	8,1	35,7	2,0	2,5	0,0670	83
A3C 160 MB2	15,0	2935	91,9	92,0	89,2	0,89	26	8,1	48,7	2,0	2,5	0,0810	93
A3C 160 L2	18,5	2935	92,4	91,8	89,5	0,89	32	8,2	60	2,0	2,5	0,0970	107
A3C 180 M2	22,0	2940	92,7	92,7	89,6	0,89	38	8,2	71	2,0	2,5	0,1370	145
4 POLES													
A3C 80 M4	0,75	1430	82,5	82,5	80,3	0,75	1,7	6,6	5,01	2,3	2,6	0,0030	11
A3C 80 MC4	1,1	1415	84,1	84,1	82,8	0,77	2,5	5,6	7,42	2,5	2,6	0,0023	15
A3C 90 S4	1,1	1435	84,1	84,1	81,6	0,76	2,5	6,8	7,32	2,3	2,6	0,0040	15
A3C 90 L4	1,5	1435	85,3	85,5	83,1	0,77	3,3	7,0	9,98	2,3	2,6	0,0050	17
A3C 90 LB4	2,2	1430	86,7	86,6	85,3	0,78	4,7	6,1	14,7	2,4	2,6	0,0056	21
A3C 100 LA4	2,2	1450	86,7	87,0	86,0	0,81	4,5	7,6	14,5	2,3	2,6	0,0120	24
A3C 100 LB4	3,0	1450	87,7	88,4	87,6	0,82	6	7,6	19,8	2,3	2,6	0,0160	28
A3C 100 LC4	4,0	1450	88,6	88,5	87,2	0,81	8	7,2	26,3	2,6	2,9	0,0145	31
A3C 112 M4	4,0	1455	88,6	88,4	87,4	0,82	7,9	7,8	26,3	2,2	2,6	0,0220	33
A3C 132 S4	5,5	1460	89,6	89,9	89,1	0,83	10,7	7,9	36,0	2,0	2,6	0,0600	48
A3C 132 MA4	7,5	1460	90,4	90,9	90,2	0,84	14	7,5	49,1	2,0	2,6	0,0710	58
A3C 132 MB4	9,2	1460	90,9	90,8	89,6	0,84	17	7,5	60	2,6	2,8	0,0472	57
A3C 132 MC4	11,0	1460	91,4	91,2	89,9	0,84	21	7,5	72	2,6	2,8	0,0511	60
A3C 160 M4	11,0	1470	91,4	91,8	91,1	0,85	20	7,7	71	2,2	2,6	0,1370	89
A3C 160 L4	15,0	1470	92,1	92,4	91,6	0,86	27	7,8	97	2,2	2,6	0,1710	105

A3C - 400 V - 50 Hz - ALUMINIUM

IE3

Motor type	Rated Output	Rated Speed	Efficiency			Power factor	Current	Starting current	Rated torque	Starting torque	Breakdown torque	Moment of Inertia	Weight
			η %			$\cos\phi$	I_n	I_s/I_n	T_n	T_s/T_n	T_{max}/T_n	J	
	kW	rpm	100%	75%	50%		A	p.u.	Nm	p.u.	p.u.	kgm ²	kg
4 POLES													
A3C 180 M4	18,5	1475	92,6	93,2	92,9	0,86	34	7,8	120	2,0	2,6	0,2380	132
A3C 180 L4	22,0	1475	93,0	93,5	93,3	0,86	40	7,8	142	2,0	2,6	0,2590	147
6 POLES													
A3C 80 MC6	0,8	930	78,9	79,0	76,2	0,70	2,0	4,2	7,70	2,5	2,7	0,0039	14
A3C 90 S6	0,8	930	78,9	79,4	77,6	0,71	1,9	6,0	7,70	2,0	2,5	0,0040	14
A3C 90 L6	1,1	930	81,0	82,1	80,5	0,73	2,7	6,0	15,1	2,0	2,5	0,0060	18
A3C 90 LB6	1,5	950	82,5	82,5	80,9	0,71	3,7	4,9	15,1	2,3	2,5	0,0075	21
A3C 100 LA6	1,5	950	82,5	82,5	80,3	0,73	3,6	6,5	21,9	2,0	2,5	0,0160	23
A3C 112 M6	2,2	960	84,3	84,4	83,2	0,74	5,1	6,6	29,5	2,0	2,5	0,0290	29
A3C 132 S6	3,0	970	85,6	85,5	84,0	0,74	6,8	6,8	39,4	2,0	2,5	0,0350	41
A3C 132 MA6	4,0	970	86,8	86,5	84,9	0,74	9,0	6,8	54,1	2,0	2,5	0,0430	48
A3C 132 MB6	5,5	970	88,0	88,5	88,0	0,75	12	7,0	54	2,0	2,5	0,0560	59
A3C 160 M6	7,5	975	89,1	90,0	90,0	0,79	15	7,0	73	2,0	2,5	0,1400	80
A3C 160 L6	11,0	975	90,3	91,1	91,1	0,80	22	7,2	108	2,0	2,5	0,1920	99
A3C 180 L6	15,0	985	91,2	91,9	91,6	0,81	29	7,3	145	2,0	2,5	0,3190	143
8 POLES													
A3C 100 LA8	0,75	690	75,0	74,4	72,5	0,67	2,2	4,0	10,38	1,8	2,3	0,0057	17
A3C 100 LB8	1,1	690	77,7	77,4	75,5	0,69	3,0	4,0	15,2	1,8	2,3	0,0085	21
A3C 112 M8	1,5	690	79,7	78,9	77,0	0,70	3,9	5,0	20,8	1,8	2,3	0,0139	27
A3C 132 SA8	2,2	710	81,9	81,3	80,2	0,71	5,5	5,5	29,6	1,8	2,3	0,0304	38
A3C 132 MA8	3,0	710	83,5	83,4	81,5	0,73	7,1	5,5	40,4	1,8	2,3	0,0412	46
A3C 160 MA8	4,0	720	84,8	84,8	82,1	0,73	9,3	6,1	53	1,9	2,4	0,0627	65
A3C 160 MB8	5,5	720	86,2	85,3	83,5	0,74	12	6,1	73	1,9	2,4	0,0862	76
A3C 160 L8	7,5	720	87,3	86,4	84,1	0,75	17	6,1	99	1,9	2,4	0,1175	92
A3C 180 L8	11,0	730	88,6	87,7	85,4	0,75	24	6,5	144	2,0	2,5	0,2042	123

B3C - 400 V - 50 Hz - ALUMINIUM - IE3

B3C - 400 V - 50 Hz - ALUMINIUM												IE3	
Motor type	Rated Output	Rated Speed	Efficiency			Power factor	Current	Starting current	Rated torque	Starting torque	Breakdown torque	Moment of Inertia	Weight
			η %			cosφ	I _n	I _s /I _n	T _n	T _s /T _n	T _{max} /T _n	J	
	kW	rpm	100%	75%	50%		A	p.u.	Nm	p.u.	p.u.	kgm ²	kg
2 POLES													
B3C 80 MA2	0,8	2910	80,7	80,9	79,0	0,82	1,6	7,0	2,5	2,3	2,46	0,0010	17
B3C 80 MB2	1,1	2910	82,7	83,2	82,5	0,83	2,3	7,3	3,7	2,2	2,46	0,0020	18
B3C 90 S2	1,5	2910	84,2	84,6	83,6	0,84	3,1	7,6	5	2,2	2,46	0,0020	23
B3C 90 L2	2,2	2910	85,9	86,3	84,8	0,85	4,3	7,6	7,3	2,2	2,46	0,0030	26
B3C 100 LA2	3,0	2910	87,1	87,9	87,4	0,87	5,7	7,8	9,9	2,2	2,46	0,0060	34
B3C 112 M2	4,0	2915	88,1	89,8	90,7	0,88	7,4	8,3	13,2	2,2	2,46	0,0090	41
B3C 132 SA2	5,5	2920	89,2	89,7	89,0	0,88	10,1	8,3	18,1	2,0	2,46	0,0240	62
B3C 132 SB2	7,5	2920	90,1	90,9	90,9	0,88	14	7,9	24,7	2,0	2,46	0,0290	67
B3C 160 MA2	11,0	2935	91,2	91,4	88,9	0,89	20	8,1	35,7	2,0	2,46	0,0670	119
B3C 160 MB2	15,0	2935	91,9	92,0	89,2	0,89	26	8,1	48,7	2,0	2,46	0,0810	130
B3C 160 L2	18,5	2935	92,4	91,8	89,5	0,89	32	8,2	60	2,0	2,46	0,0970	147
B3C 180 M2	22,0	2940	92,7	92,7	89,6	0,89	38	8,2	71	2,0	2,46	0,1370	190
B3C 200 LA2	30,0	2950	93,3	93,4	89,1	0,89	52	7,6	97	2,0	2,46	0,2270	249
B3C 200 LB2	37,0	2950	93,7	93,7	89,4	0,89	64	7,6	119	2,0	2,46	0,2690	266
B3C 225 M2	45,0	2970	94,0	94,2	92,2	0,90	77	7,7	145	2,0	2,46	0,3600	312
B3C 250 M2	55,0	2970	94,3	94,1	90,7	0,90	94	7,7	177	2,0	2,46	0,7910	413
B3C 280 S2	75,0	2975	94,7	94,7	92,9	0,90	127	7,1	241	1,8	2,46	0,9600	539
B3C 280 M2	90,0	2975	95,0	95,5	94,6	0,90	152	7,1	289	1,8	2,46	1,1570	585
B3C 315 S2	110,0	2980	95,2	95,1	93,4	0,90	185	7,1	353	1,8	2,46	1,6620	848
B3C 315 M2	132,0	2980	95,4	95,4	93,5	0,90	222	7,1	423	1,8	2,46	1,8740	966
B3C 315 LA2	160,0	2980	95,6	95,5	93,8	0,91	265	7,2	513	1,8	2,46	2,1460	1028
B3C 315 LB2	200,0	2980	95,8	95,7	94,0	0,91	331	7,2	641	1,6	2,34	2,4480	1095
B3C 355 M2	250,0	2980	95,8	95,7	94,0	0,91	414	7,2	801	1,6	2,34	4,0340	1617
B3C 355 LA2	315,0	2980	95,8	95,7	94,0	0,91	522	7,2	1010	1,6	2,34	4,6450	1784
B3C 355 KB2	355,0	2980	95,8	95,7	94,0	0,91	588	7,5	1138	1,6	2,34	5,2420	2228
B3C 355 KC2	400,0	2980	95,8	95,7	94,0	0,91	662	7,5	1282	1,6	2,34	6,1310	2288
B3C 355 KD2	450,0	2980	95,8	95,7	94,0	0,91	745	7,5	1442	1,6	2,34	6,6210	2359

B3C - 400 V - 50 Hz - CAST IRON

IE3

Motor type	Rated Output	Rated Speed	Efficiency			Power factor	Current	Starting current	Rated torque	Starting torque	Breakdown torque	Moment of Inertia	Weight
			η %			cosφ	I _n	I _s /I _n	T _n	T _s /T _n	T _{max} /T _n	J	
	kW	rpm	100%	75%	50%		A	p.u.	Nm	p.u.	p.u.	kgm ²	kg
4 POLES													
B3C 80 M4	0,8	1430	82,5	82,5	80,3	0,75	1,7	6,6	5,01	2,3	2,6	0,0030	18
B3C 90 S4	1,1	1435	84,1	84,1	81,6	0,76	2,5	6,8	7,32	2,3	2,6	0,0040	23
B3C 90 L4	1,5	1435	85,3	85,5	83,1	0,77	3,3	7,0	9,98	2,3	2,6	0,0050	26
B3C 100 LA4	2,2	1450	86,7	87,0	86,0	0,81	4,5	7,6	14,5	2,3	2,6	0,0120	36
B3C 100 LB4	3,0	1450	87,7	88,4	87,6	0,82	6	7,6	19,8	2,3	2,6	0,0160	40
B3C 112 M4	4,0	1455	88,6	88,4	87,4	0,82	7,9	7,8	26,3	2,2	2,6	0,0220	48
B3C 132 S4	5,5	1460	89,6	89,9	89,1	0,83	10,7	7,9	36,0	2,0	2,6	0,0600	68
B3C 132 MA4	7,5	1460	90,4	90,9	90,2	0,84	14	7,5	49,1	2,0	2,6	0,0710	80
B3C 160 M4	11,0	1470	91,4	91,8	91,1	0,85	20	7,7	71	2,2	2,6	0,1370	127
B3C 160 L4	15,0	1470	92,1	92,4	91,6	0,86	27	7,8	97	2,2	2,6	0,1710	148
B3C 180 M4	18,5	1475	92,6	93,2	92,9	0,86	34	7,8	120	2,0	2,6	0,2380	179
B3C 180 L4	22,0	1475	93,0	93,5	93,3	0,86	40	7,8	142	2,0	2,6	0,2590	197
B3C 200 L4	30,0	1475	93,6	93,8	93,4	0,86	54	7,3	194	2,0	2,6	0,4590	258
B3C 225 S4	37,0	1480	93,9	94,1	93,8	0,86	66	7,4	239	2,0	2,6	0,6560	314
B3C 225 M4	45,0	1480	94,2	94,4	94,0	0,86	80	7,4	290	2,0	2,6	0,7580	340
B3C 250 M4	55,0	1485	94,6	94,7	94,0	0,86	98	7,4	354	2,2	2,6	1,0780	419
B3C 280 S4	75,0	1485	95,0	95,1	94,6	0,88	129	6,9	482	2,0	2,6	1,8000	588
B3C 280 M4	90,0	1485	95,2	95,4	94,9	0,88	155	6,9	579	2,0	2,6	2,1300	664
B3C 315 S4	110,0	1490	95,4	95,4	94,8	0,89	187	7,0	705	2,0	2,5	3,4150	855
B3C 315 M4	132,0	1490	95,6	95,7	95,3	0,89	224	7,0	846	2,0	2,5	3,8070	998
B3C 315 LA4	160,0	1490	95,8	95,9	95,5	0,89	271	7,1	1026	2,0	2,5	3,4230	1073
B3C 315 LB4	200,0	1490	96,0	96,3	96,1	0,90	334	7,1	1282	2,0	2,5	5,2620	1177
B3C 355 M4	250,0	1490	96,0	96,3	96,1	0,90	418	7,1	1602	2,0	2,5	6,1920	1691
B3C 355 LA4	315,0	1490	96,0	96,2	95,8	0,90	526	7,1	2019	2,0	2,5	7,2730	1925
B3C 355 KB4	355,0	1490	96,0	96,3	95,8	0,88	607	7,0	2275	1,7	2,5	16,2437	2335
B3C 355 KC4	400,0	1490	96,0	96,1	95,8	0,88	683	7,0	2564	1,7	2,5	13,3771	2396
B3C 355 KD4	450,0	1490	96,0	96,3	95,9	0,88	769	7,0	2884	1,7	2,5	14,8104	2456

B3C - 400 V - 50 Hz - CAST IRON

IE3

Motor type	Rated Output	Rated Speed	Efficiency			Power factor	Current	Starting current	Rated torque	Starting torque	Breakdown torque	Moment of Inertia	Weight
			η %			cosφ	I _n	I _s /I _n	T _n	T _s /T _n	T _{max} /T _n	J	
	kW	rpm	100%	75%	50%		A	p.u.	Nm	p.u.	p.u.	kgm ²	kg
6 POLES													
B3C 90 S6	0,8	930	78,9	79,4	77,6	0,71	1,9	6,0	7,7	2,0	2,5	0,0040	22
B3C 90 L6	1,1	930	81,0	82,1	80,5	0,73	2,7	6,0	11,3	2,0	2,5	0,0060	27
B3C 100 LA6	1,5	950	82,5	82,5	80,3	0,73	3,6	6,5	15,1	2,0	2,5	0,0160	34
B3C 112 M6	2,2	960	84,3	84,4	83,2	0,74	5,1	6,6	21,9	2,0	2,5	0,0290	43
B3C 132 S6	3,0	970	85,6	85,5	84,0	0,74	6,8	6,8	29,5	2,0	2,5	0,0350	60
B3C 132 MA6	4,0	970	86,8	86,5	84,9	0,74	9,0	6,8	39,4	2,0	2,5	0,0430	70
B3C 132 MB6	5,5	970	88,0	88,5	88,0	0,75	12	7,0	54	2,0	2,5	0,0560	81
B3C 160 M6	7,5	975	89,1	90,0	90,0	0,79	15	7,0	73	2,0	2,5	0,1400	116
B3C 160 L6	11,0	975	90,3	91,1	91,1	0,80	22	7,2	108	2,0	2,5	0,1920	139
B3C 180 L6	15,0	985	91,2	91,9	91,6	0,81	29	7,3	145	2,0	2,5	0,3190	192
B3C 200 LA6	18,5	980	91,7	91,9	91,2	0,81	36	7,3	180	2,0	2,5	0,4460	233
B3C 200 LB6	22,0	980	92,2	92,4	91,4	0,81	43	7,4	214	2,0	2,5	0,5570	250
B3C 225 M6	30,0	980	92,6	93,0	92,2	0,83	56	6,9	292	2,0	2,5	0,8320	300
B3C 250 M6	37,0	980	93,3	93,7	93,5	0,84	68	7,1	361	2,0	2,5	1,4470	400
B3C 280 S6	45,0	980	93,7	94,0	93,5	0,85	82	7,3	439	2,0	2,4	2,2520	509
B3C 280 M6	55,0	980	94,1	94,4	93,9	0,86	98	7,3	536	2,0	2,4	2,7260	576
B3C 315 S6	75,0	990	94,6	94,8	94,3	0,84	136	6,6	723	2,0	2,4	3,9840	787
B3C 315 M6	90,0	990	94,9	95,1	94,5	0,85	161	6,7	868	2,0	2,4	4,5000	935
B3C 315 LA6	110,0	990	95,1	95,3	94,8	0,85	196	6,7	1061	2,0	2,4	5,6070	1017
B3C 315 LB6	132,0	990	95,4	95,5	94,8	0,86	232	6,8	1273	2,0	2,4	6,9350	1091
B3C 355 MA6	160,0	990	95,6	95,8	95,4	0,86	281	6,8	1543	1,8	2,4	10,2200	1617
B3C 355 MB6	200,0	990	95,8	96,0	95,7	0,87	346	6,8	1929	1,8	2,4	11,0300	1775
B3C 355 LA6	250,0	990	95,8	96,0	95,7	0,87	433	6,8	2412	1,8	2,4	11,8970	2174
B3C 355 KB6	315,0	990	95,8	96,1	95,8	0,86	552	6,8	3039	1,8	2,4	14,9900	2434
B3C 355 KC6	355,0	990	95,8	96,1	95,8	0,86	622	6,8	3424	1,8	2,4	19,6030	2505

B3C - 400 V - 50 Hz - CAST IRON

IE3

Motor type	Rated Output	Rated Speed	Efficiency			Power factor	Current	Starting current	Rated torque	Starting torque	Breakdown torque	Moment of Inertia	Weight
			η %			cosφ	I _n	I _s /I _n	T _n	T _s /T _n	T _{max} /T _n	J	
	kW	rpm	100%	75%	50%		A	p.u.	Nm	p.u.	p.u.	kgm ²	kg
8 POLES													
B3C 100 LA8	0,8	690	75,0	74,4	72,5	0,67	2,2	4,0	10,38	1,8	2,3	0,0057	29
B3C 100 LB8	1,1	690	77,7	77,4	75,5	0,69	3,0	4,0	15,2	1,8	2,3	0,0085	33
B3C 112 M8	1,5	690	79,7	78,9	77,0	0,70	3,9	5,0	20,8	1,8	2,3	0,0139	42
B3C 132 S8	2,2	710	81,9	81,3	80,2	0,71	5,5	5,5	29,6	1,8	2,3	0,0304	59
B3C 132 MA8	3,0	710	83,5	83,4	81,5	0,73	7,1	5,5	40,4	1,8	2,3	0,0412	69
B3C 160 MA8	4,0	720	84,8	84,8	82,1	0,73	9,3	6,1	53	1,9	2,4	0,0627	102
B3C 160 MB8	5,5	720	86,2	85,3	83,5	0,74	12	6,1	73	1,9	2,4	0,0862	113
B3C 160 L8	7,5	720	87,3	86,4	84,1	0,75	17	6,1	99	1,9	2,4	0,1175	132
B3C 180 L8	11,0	730	88,6	87,7	85,4	0,75	24	6,5	144	2,0	2,5	0,2042	171
B3C 200 L8	15,0	730	89,6	88,9	86,6	0,76	32	6,6	196	2,0	2,5	0,3132	217
B3C 225 S8	18,5	730	90,1	89,0	86,9	0,76	39	6,6	242	2,0	2,5	0,4773	259
B3C 225 M8	22,0	740	90,6	89,5	87,7	0,78	45	6,6	284	2,0	2,5	0,5455	278
B3C 250 M8	30,0	740	91,3	90,4	88,6	0,79	60	6,5	387	2,1	2,4	0,8861	373
B3C 280 S8	37,0	740	91,8	90,9	89,4	0,79	74	6,6	478	2,1	2,4	1,5400	484
B3C 280 M8	45,0	740	92,2	91,4	90,1	0,79	89	6,6	581	2,1	2,4	1,8313	536
B3C 315 S8	55,0	740	92,5	91,6	90,4	0,81	106	6,7	710	1,9	2,3	3,4522	721
B3C 315 M8	75,0	740	93,1	92,0	90,9	0,81	144	6,7	968	1,9	2,3	4,4016	865
B3C 315 LA8	90,0	740	93,4	92,3	91,3	0,82	170	6,7	1161	1,9	2,3	5,8688	972
B3C 315 LB8	110,0	740	93,7	92,8	91,7	0,82	207	6,7	1420	1,9	2,3	7,2497	1077
B3C 355 MA8	132,0	740	94,0	93,1	92,0	0,82	247	6,7	1704	1,9	2,3	11,1200	1518
B3C 355 MB8	160,0	740	94,3	93,6	92,5	0,82	299	6,4	2065	1,8	2,1	13,1664	1630
B3C 355 LA8	200,0	740	94,6	94,0	93,0	0,83	368	6,4	2581	1,8	2,1	16,6800	1819
B3C 355 KB8	250,0	740	94,6	94,0	93,0	0,83	460	6,4	3226	1,7	2,0	21,8500	2430
B3C 355 KC8	315,0	740	94,6	94,0	93,0	0,83	579	6,4	4065	1,7	2,0	26,2100	2500

B3

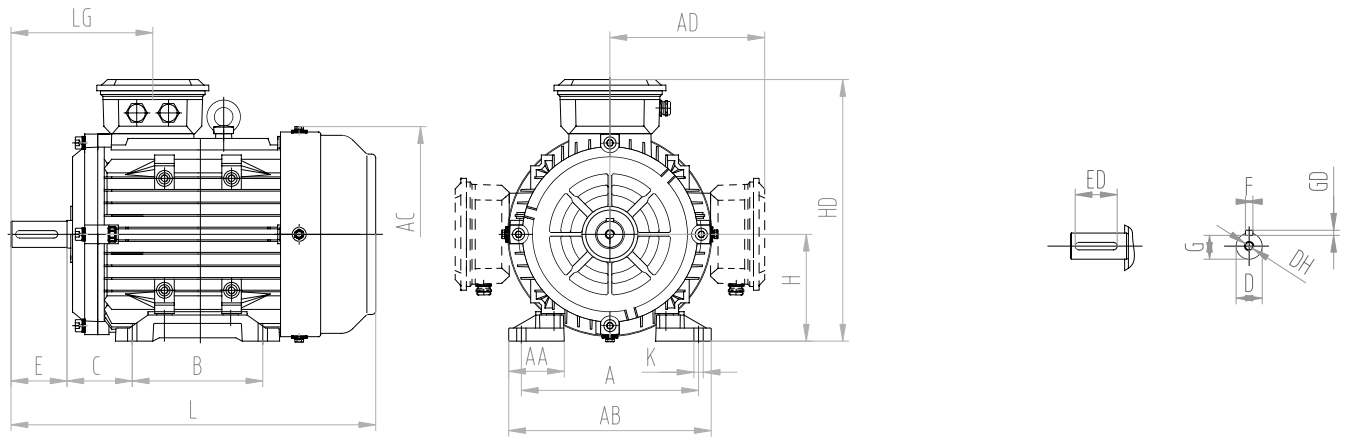

B3

	Motor Type	Poles	Shaft extension							Dimensions													
			D	E	ED	F	G	GD	DH	A	AA	AB	B	BB	C	HA	K	AC	AD	H	HD	L	LG
A1C-A2C	63 MA-MB	2-6	11 j6	23	16	4	8,5	4	M4*10	100	36	125	80	102	40	9	7	128	104	63	167	223,5	86
	71 MA-MB	2-6	14 j6	30	25	5	11	5	M5*16	112	40	140	90	115	45	10	8	145	112,5	71	183,5	258	98
	80 MA-MB	2-8	19 j6	40	32	6	15,5	6	M6*16	125	44	158	100	125	50	10	10	165	122,5	80	202,5	292	117
	90 S	2-8	24 j6	50	40	8	20	7	M8*19	140	50	175	100	130	56	12	10	190	130	90	220	323,5	131
	90 L	2-8	24 j6	50	40	8	20	7	M8*19	140	50	175	125	155	56	12	10	190	130	90	220	349	131
	100 LA-LB	2-8	28 j6	60	50	8	24	7	M10*22	160	54	200	140	175	63	14	12	205	158	100	258	385	149
	112 M	2-8	28 j6	60	50	8	24	7	M10*22	190	60	222	140	178	70	15	12	240	169	112	281	409	152
	132 S-SB	2-8	38 k6	80	70	10	33	8	M12*28	216	65	255	140	185	89	16	13	275	190	132	322	479	180
	132 MA-MB	2-8	38 k6	80	70	10	33	8	M12*28	216	65	255	178	225	89	16	13	275	190	132	322	520	180
	160 M-MB	2-8	42 k6	110	90	12	37	8	M16*36	254	55	306	210	259	108	18	14,5	330	243	160	403	614	269
	160 L	2-8	42 k6	110	90	12	37	8	M16*36	254	55	306	254	303	108	18	15	330	243	160	403	658	269
	180M	2-8	48 k6	110	100	14	42,5	9	M16*36	279	60	340	241	300	121	22	15	380	270	180	450	703	269
	180L	2-8	48 k6	110	100	14	42,5	9	M16*36	279	60	340	279	338	121	22	15	380	270	180	450	740	269

B5-V1

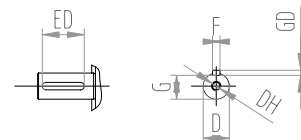
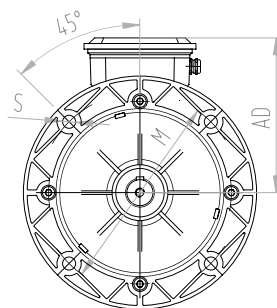
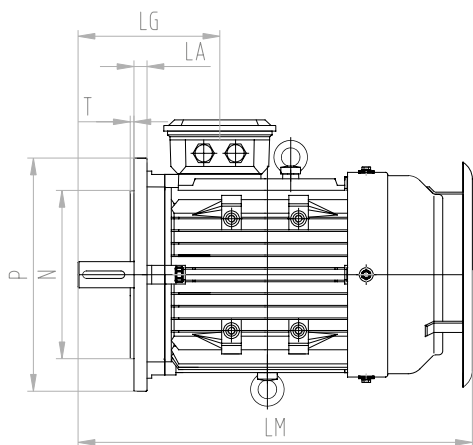

B14

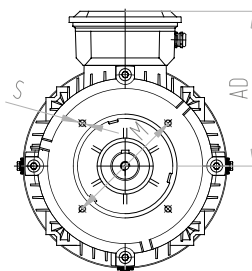
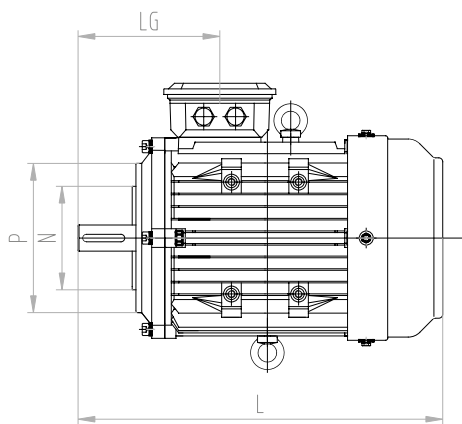

B5-V1 / B14

Motor Type	Poles	Shaft extension							Dimensions					
		D	E	ED	F	G	GD	DH	AC	AD	L	LM ⁽¹⁾	LG	
A1C-A2C	63 MA-MB	2-6	11 j6	23	16	4	8,5	4	M4*10	128	104	223,5	-	86
	71 MA-MB	2-6	14 j6	30	25	5	11	5	M5*16	145	112,5	258	-	98
	80 MA-MB	2-8	19 j6	40	32	6	15,5	6	M6*16	165	122,5	292	332	117
	90 S/L	2-8	24 j6	50	40	8	20	7	M8*19	190	130	323,5	368,5	131
			24 j6	50	40	8	20	7	M8*19	190	130	349	394	131
	100 LA-LB	2-8	28 j6	60	50	8	24	7	M10*22	205	158	385	430	149
			28 j6	60	50	8	24	7	M10*22	240	169	409	461	152
	132 S-SB	2-8	38 k6	80	70	10	33	8	M12*28	275	190	479	531	180
			38 k6	80	70	10	33	8	M12*28	275	190	520	572	180
	160 M-MB	2-8	42 k6	110	90	12	37	8	M16*36	330	243	614	681	269
	160 L		42 k6	110	90	12	37	8	M16*36	330	243	658	725	269
	180M/L	2-8	48 k6	110	100	14	42,5	9	M16*36	380	270	703	772	345
			48 k6	110	100	14	42,5	9	M16*36	380	270	740	809	345

Motor Type	Poles	Dimensions						
		IM	LA	M	N j6	P	S	T
63 MA-MB	2-6	B5	10	115	95	140	4*10	3
		B14	-	75	60	90	4*M5	2,5
71 MA-MB	2-6	B5	10	130	110	160	4*10	3,5
		B14	-	85	70	105	4*M6	2,5
80 MA-MB	2-8	B5	12	165	130	200	4*12	3,5
		B14	-	100	80	120	4*M6	3
90 S/L	2-8	B5	12	165	130	200	4*12	3,5
		B14	-	115	95	140	4*M8	3
100 LA-LB	2-8	B5	14	215	180	250	4*14,5	4
		B14	-	130	110	160	4*M8	3,5
112 M-MA	2-8	B5	14	215	180	250	4*14,5	4
		B14	-	130	110	160	4*M8	3,5
132 S-SB	2-8	B5	16	265	230	300	4*14,5	4
132 MA-MB		B14	-	165	130	200	4*M10	3,5
160 M-MB	2-8	B5	16	300	250	350	4*18,5	5
160 L		B14	-	215	180	250	4*M12	4
180M/L	2-8	B5	16	300	250	350	4*18,5	5
		B14	-	215	180	250	4*M12	4

⁽¹⁾ Dimension with canopy

B3

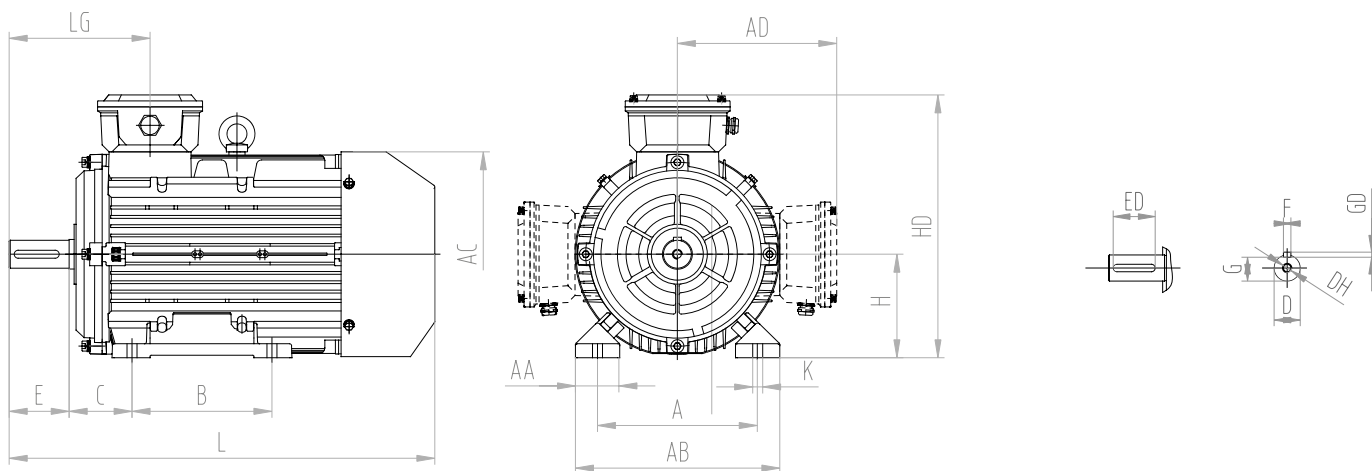

B3

	Motor Type	Poles	Shaft extension							Dimensions													
			D	E	ED	F	G	GD	DH	A	AA	AB	B	BB	C	HA	K	AC	AD	H	HD	L	LG
A3C	80 MA-MB	2-8	19 j6	40	32	6	15,5	6	M6*16	125	35	154	100	130	50	11	10	175	140	80	220	301,5	109
	90 S	2-8	24 j6	50	40	8	20	7	M8*19	140	37	180	100	130	56	13	10	195	148	90	238	355	120
	90 L	2-8	24 j6	50	40	8	20	7	M8*19	140	37	180	125	155	56	13	10	195	148	90	238	386	120
	100 LA-LB	2-8	28 j6	60	50	8	24	7	M10*22	160	45	200	140	180	63	14	12	215	164	100	264	431,5	141
	112 M	2-8	28 j6	60	50	8	24	7	M10*22	190	60	222	140	178	70	15	12	240	169	112	281	397	152
	132 S-SB	2-8	38 k6	80	70	10	33	8	M12*28	216	65	255	140	185	89	16	13	275	190	132	322	473	180
	132 MA-MB	2-8	38 k6	80	70	10	33	8	M12*28	216	65	255	178	225	89	16	13	275	190	132	322	514	180
	160 M-MB	2-8	42 k6	110	90	12	37	8	M16*36	254	55	306	210	259	108	18	14,5	330	243	160	403	617	269
	160 L	2-8	42 k6	110	90	12	37	8	M16*36	254	55	306	254	303	108	18	15	330	243	160	403	662	269
	180 M	2-8	48 k6	110	100	14	42,5	9	M16*36	279	60	340	241	300	121	22	15	380	270	180	450	697	269
180 L	2-8	48 k6	110	100	14	42,5	9	M16*36	279	60	340	279	338	121	22	15	380	270	180	450	733,5	269	

B5-V1

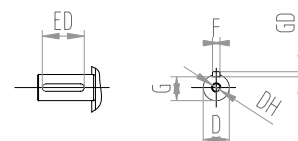
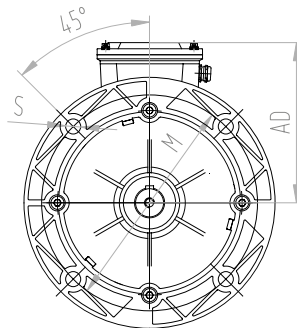
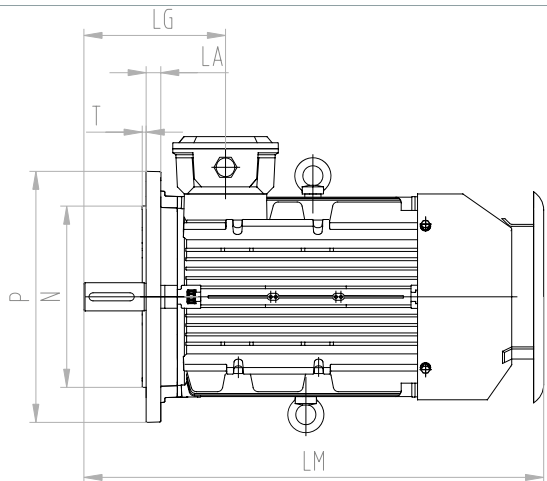

B14

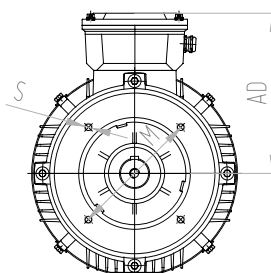
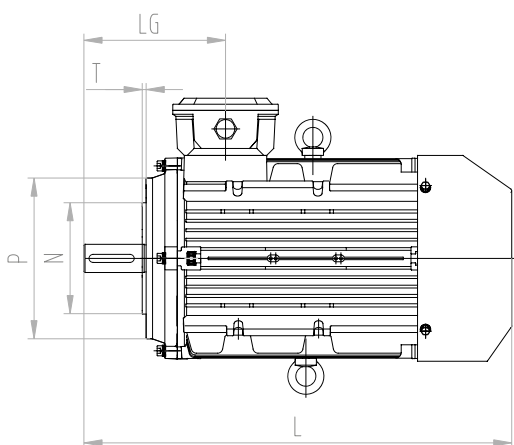

B5-V1 / B14

A3C	Motor Type	Poles	Shaft extension						Dimensions					
			D	E	ED	F	G	GD	DH	AC	AD	L	LM ⁽¹⁾	LG
	80 MA-MB	2-8	19 j6	40	32	6	15,5	6	M6*16	175	140	301,5	341,5	109
	90S/L	2-8	24 j6	50	40	8	20	7	M8*19	195	148	355	395	120
			24 j6	50	40	8	20	7	M8*19	195	148	386	426	120
	100 LA-LB	2-8	28 j6	60	50	8	24	7	M10*22	215	164	431,5	476,5	141
	112 M	2-8	28 j6	60	50	8	24	7	M10*22	240	169	397	449	152
	132 S-SB	2-8	38 k6	80	70	10	33	8	M12*28	275	190	473	525	180
	132 MA-MB		38 k6	80	70	10	33	8	M12*28	275	190	514	566	180
	160 M-MB	2-8	42 k6	110	90	12	37	8	M16*36	330	243	617	684	269
	160 L		42 k6	110	90	12	37	8	M16*36	330	243	662	729	269
	180M/L	2-8	48 k6	110	100	14	42,5	9	M16*36	380	270	697	766	345
48 k6			110	100	14	42,5	9	M16*36	380	270	733,5	802,5	345	

Motor Type	Poles	Dimensions						
		IM	LA	M	N j6	P	S	T
80 MA-MB	2-8	B5	12	165	130	200	4*12	3,5
		B14	-	100	80	120	4*M6	3
90S/L	2-8	B5	12	165	130	200	4*12	3,5
		B14	-	115	95	140	4*M8	3
100 LA-LB	2-8	B5	14	215	180	250	4*14,5	4
		B14	-	130	110	160	4*M8	3,5
112 M	2-8	B5	14	215	180	250	4*14,5	4
		B14	-	130	110	160	4*M8	3,5
132 S-SB	2-8	B5	16	265	230	300	4*14,5	4
132 MA-MB		B14	-	165	130	200	4*M10	3,5
160 M-MB	2-8	B5	16	300	250	350	4*18,5	5
160 L		B14	-	215	180	250	4*M12	4
180M/L	2-8	B5	16	300	250	350	4*18,5	5
		B14	-	215	180	250	4*M12	4

⁽¹⁾ Dimension with canopy. For B5 mounting consider dimension "L".

B3

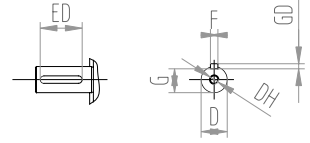
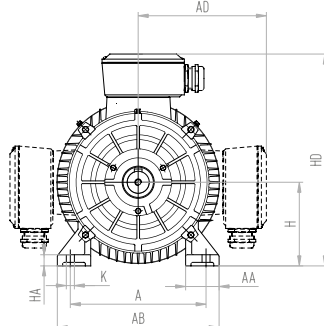
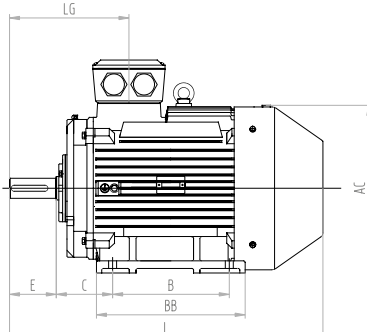

B3

Motor Type	Poles	Shaft extension							Dimensions															
		D	E	ED	F	G	GD	DH	A	AA	AB	B	BB	C	HA	K	AC	AD	H	HD	L	LG		
		Left Side	Top	Right Side																				
63 MA-MB	2-6	11 j6	23	16	4	8,5	4	M4*10	100	30	130	80	110	40	8	7	-	137	63	200	230	-	92,5	-
71 MA-MB	2-6	14 j6	30	25	5	11	5	M5*16	112	32	144	90	120	45	8	7	141	144	71	215	249	-	102	-
80 MA-MB	2-8	19 j6	40	32	6	15,5	6	M6*16	125	34	160	100	126	50	10	10	175	160	80	240	295	140	112	140
90 S	2-8	24 j6	50	40	8	20	7	M8*19	140	36	176	100	130	56	12,5	10	190	170	90	260	320	156	126	156
90 L	2-8	24 j6	50	40	8	20	7	M8*19	140	36	176	125	155	56	12,5	10	190	170	90	260	345	168,5	126	168,5
100 LA-LB	2-8	28 j6	60	50	8	24	7	M10*22	160	40	200	140	176	63	14	12	215	180	100	280	385	193	139	193
112 M	2-8	28 j6	60	50	8	24	7	M10*22	190	45	226	140	180	70	14	12	236	195	112	307	410	200	144	200
132 S-SB	2-8	38 k6	80	70	10	33	8	M12*28	216	53	262	140	200	89	16	12	275	215	132	347	480	239	167	239
132 MA-MB	2-8	38 k6	80	70	10	33	8	M12*28	216	53	262	178	238	89	16	12	275	215	132	347	520	258	167	258
160 M-MB	2-8	42 k6	110	90	12	37	8	M16*36	254	65	314	210	258	108	19	14,5	330	255	160	415	610	260	260	260
160 L	2-8	42 k6	110	90	12	37	8	M16*36	254	65	314	254	302	108	19	14,5	330	255	160	415	655	260	260	260
180 M	2-8	48 k6	110	100	14	42,5	9	M16*36	279	68	345	241	282	121	22	14,5	380	275	180	455	680	272	272	272
180 L	2-8	48 k6	110	100	14	42,5	9	M16*36	279	68	345	279	320	121	22	14,5	380	275	180	455	720	272	272	272
200 L-LB	2-8	55 m6	110	100	16	49	10	M20*42	318	78	388	305	353	133	25	18,5	420	310	200	510	760	298	298	298
225 M	2	55 m6	110	100	16	49	10	M20*42	356	75	431	311	373	149	28	18,5	465	330	225	555	820	308	308	308
225 S	4-8	60 m6	140	125	18	53	11	M20*42	356	75	431	286	348	149	28	18,5	465	330	225	555	825	338	338	338
225 M	4-8	60 m6	140	125	18	53	11	M20*42	356	75	431	311	373	149	28	18,5	465	330	225	555	850	338	338	338
250 M	2	60 m6	140	125	18	53	11	M20*42	406	100	484	349	445	168	33	24	520	375	250	625	925	357	357	357
250 M	4-8	65 m6	140	125	18	58	11	M20*42	406	100	484	349	445	168	33	24	520	375	250	625	925	357	357	357
280 S	2	65 m6	140	125	18	58	11	M20*42	457	105	546	368	485	190	35	24	570	405	280	685	970	357	357	357
280 S	4-8	75 m6	140	125	20	67,5	12	M20*42	457	105	546	368	485	190	35	24	570	405	280	685	990	357	357	357
280 M	2	65 m6	140	125	18	58	11	M20*42	457	105	546	419	536	190	35	24	570	405	280	685	1025	357	357	357
280 M	4-8	75 m6	140	125	20	67,5	12	M20*42	457	105	546	419	536	190	35	24	570	405	280	685	1045	357	357	357
315 S	2	65 m6	140	125	18	58	11	M20*42	508	122	624	406	511	216	45	28	650	490	315	805	1160	743	392	392
315 S	4-12	80 m6	170	140	22	71	14	M20*42	508	122	624	406	511	216	45	28	650	490	315	805	1190	773	422	422
315 MA	2	65 m6	140	125	18	58	11	M20*42	508	122	624	457	621	216	45	28	650	490	315	805	1270	853	392	392
315 MA	4-12	80 m6	170	140	22	71	14	M20*42	508	122	624	457	621	216	45	28	650	490	315	805	1300	883	422	422
315 MB	2	65 m6	140	125	18	58	11	M20*42	508	122	624	508	621	216	45	28	650	490	315	805	1270	853	392	392
315 MB	4-12	80 m6	170	140	22	71	14	M20*42	508	122	624	508	621	216	45	28	650	490	315	805	1300	883	422	422

B5-V1

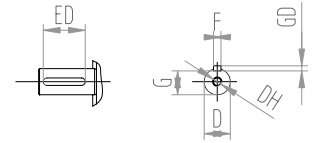
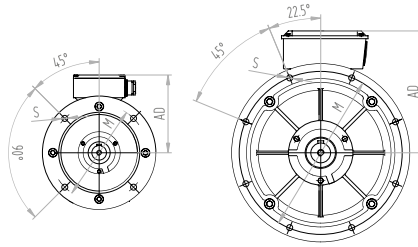
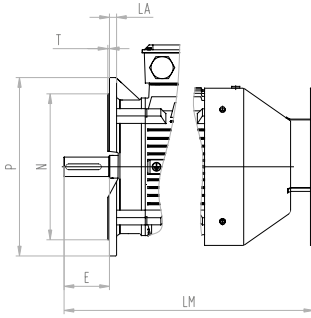

B14

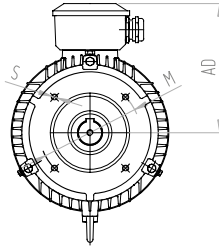
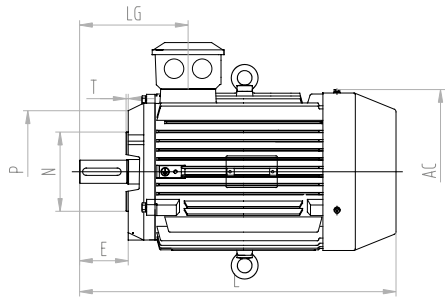

B5-V1 / B14

Motor Type	Poles	Shaft extension							Dimensions						
		D	E	ED	F	G	GD	DH	AC	AD	L	LM ⁽¹⁾	LG		
		Left Side	Top	Right Side											
63 MA-MB	2-6	11 j6	23	16	4	8,5	4	M4*10	-	137	230	-	-	92,5	-
71 MA-MB	2-6	14 j6	30	25	5	11	5	M5*16	141	144	249	-	-	102	-
80 MA-MB	2-8	19 j6	40	32	6	15,5	6	M6*16	175	160	295	335	140	112	140
90 S	2-8	24 j6	50	40	8	20	7	M8*19	190	170	320	360	156	126	156
90 L		24 j6	50	40	8	20	7	M8*19	190	170	345	385	168,5	126	168,5
100 LA-LB	2-8	28 j6	60	50	8	24	7	M10*22	215	180	385	430	193	139	193
112 M-MA	2-8	28 j6	60	50	8	24	7	M10*22	236	195	410	460	200	144	200
132 S-SB	2-8	38 k6	80	70	10	33	8	M12*28	275	215	480	530	239	167	239
132 MA-MB		38 k6	80	70	10	33	8	M12*28	275	215	520	570	258	167	258
160 M-MB	2-8	42 k6	110	90	12	37	8	M16*36	330	255	610	665	260	260	260
160 L		42 k6	110	90	12	37	8	M16*36	330	255	655	720	260	260	260
180 M	2-8	48 k6	110	100	14	42,5	9	M16*36	380	275	680	755	272	272	272
180 L		48 k6	110	100	14	42,5	9	M16*36	380	275	720	795	272	272	272
200 L-LB	2-8	55 m6	110	100	16	49	10	M20*42	420	310	760	845	298	298	298
225 M	2	55 m6	110	100	16	49	10	M20*42	465	330	820	890	308	308	308
225 S	4-8	60 m6	140	125	18	53	11	M20*42	465	330	825	895	338	338	338
225 M	4-8	60 m6	140	125	18	53	11	M20*42	465	330	850	920	338	338	338
250 M	2	60 m6	140	125	18	53	11	M20*42	520	375	925	1015	357	357	357
250 M	4-8	65 m6	140	125	18	58	11	M20*42	520	375	925	1015	357	357	357
280 S	2	65 m6	140	125	18	58	11	M20*42	570	405	970	1075	357	357	357
280 S	4-8	75 m6	140	125	20	67,5	12	M20*42	570	405	990	1075	357	357	357
280 M	2	65 m6	140	125	18	58	11	M20*42	570	405	1025	1125	357	357	357
280 M	4-8	75 m6	140	125	20	67,5	12	M20*42	570	405	1045	1125	357	357	357
315 S	2	65 m6	140	125	18	58	11	M20*42	650	490	1160	1250	743	392	392
315 S	4-12	80 m6	170	140	22	71	14	M20*42	650	490	1190	1280	773	422	422
315 MA	2	65 m6	140	125	18	58	11	M20*42	650	490	1270	1360	853	392	392
315 MA	4-12	80 m6	170	140	22	71	14	M20*42	650	490	1300	1390	883	422	422
315 MB	2	65 m6	140	125	18	58	11	M20*42	650	490	1270	1360	853	392	392
315 MB	4-12	80 m6	170	140	22	71	14	M20*42	650	490	1300	1390	883	422	422

Motor Type	Poles	Dimensions						
		IM	LA	M	N j6	P	S	T
63 MA-MB	2-6	B5	11,5	115	95	140	4*10	3
		B14	-	75	60	90	4*M5	2
71 MA-MB	2-6	B5	11,5	130	110	160	4*10	3,5
		B14	-	85	70	105	4*M6	2
80 MA-MB	2-8	B5	12	165	130	200	4*12	3,5
		B14	-	100	80	120	4*M6	3
90 S	2-8	B5	12	165	130	200	4*12	3,5
90 L		B14	-	115	95	140	4*M8	3
100 LA-LB	2-8	B5	14	215	180	250	4*14,5	4
		B14	-	130	110	160	4*M8	3,5
112 M-MA	2-8	B5	14	215	180	250	4*14,5	4
		B14	-	130	110	160	4*M8	3,5
132 S-SB	2-8	B5	14	265	230	300	4*14,5	4
132 MA-MB		B14	-	165	130	200	4*M10	3,5
160 M-MB	2-8	B5	15	300	250	350	4*18,5	5
160 L		B14	-	215	180	250	4*M12	4
180 M	2-8	B5	15	300	250	350	4*18,5	5
180 L		B14	-	215	180	250	4*M12	4
200 L-LB	2-8	B5	17	350	300	400	4*18,5	5
225 M	2	B5	19	400	350	450	8*18,5	5
225 S	4-8	B5	19	400	350	450	8*18,5	5
225 M	4-8	B5	19	400	350	450	8*18,5	5
250 M	2	B5	22	500	450	550	8*18,5	5
250 M	4-8	B5	22	500	450	550	8*18,5	5
280 S	2	B5	22	500	450	550	8*18,5	5
280 S	4-8	B5	22	500	450	550	8*18,5	5
280 M	2	B5	22	500	450	550	8*18,5	5
280 M	4-8	B5	22	500	450	550	8*18,5	5
315 S	2	B5	24	600	550	660	8*24	6
315 S	4-12	B5	24	600	550	660	8*24	6
315 MA	2	B5	24	600	550	660	8*24	6
315 MA	4-12	B5	24	600	550	660	8*24	6
315 MB	2	B5	24	600	550	660	8*24	6
315 MB	4-12	B5	24	600	550	660	8*24	6

⁽¹⁾ Dimension with canopy. For B5 mounting consider dimension "L".

B3

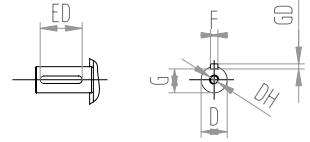
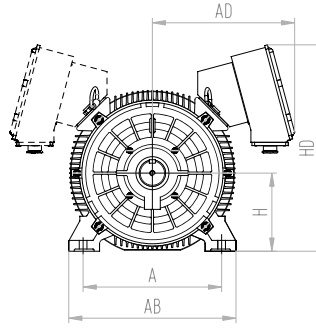
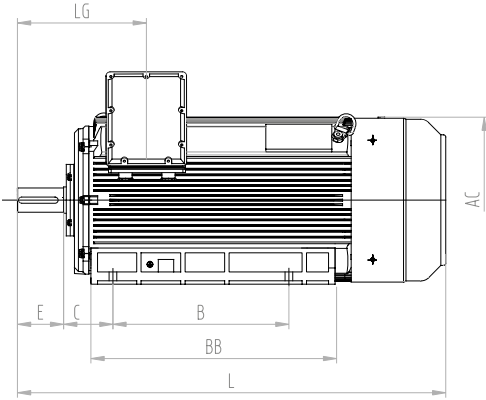

V1

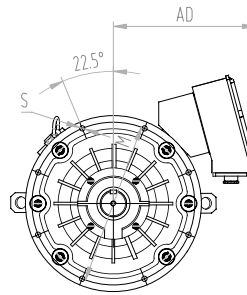
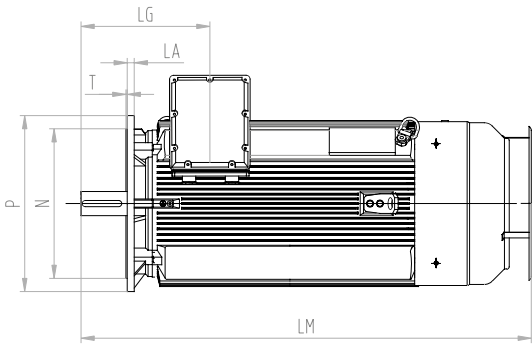

B3

B1C - B2C	Motor Type	Poles	Shaft extension							Dimensions															
			D	E	ED	F	G	GD	DH	A	AA	AB	B	BB	C	HA	K	AC	AD	H	HD	L	LG		
			Left Side	Top	Right Side																				
*355 M-MB	2	75 m6	140	125	20	67,5	12	M20*42	610	120	730	560	850	254	50	28	735	645	355	1000	1600	-	415	415	
*355 M-MB	4-12	100 m6	210	180	28	90	16	M24*50	610	120	730	560	850	254	50	28	735	645	355	1000	1670	-	485	485	
*355 LA-LB	2	75 m6	140	125	20	67,5	12	M20*42	610	120	730	630	850	254	50	28	735	645	355	1000	1600	-	415	415	
*355 LA-LB	4-12	100 m6	210	180	28	90	16	M24*50	610	120	730	630	850	254	50	28	735	645	355	1000	1670	-	485	485	
355 KB-KD	2	75 m6	140	125	20	67,5	12	M20*42	630	135	760	800	1140	224	52	35	800	770	355	1000	1840	513,5	513,5	513,5	
355 KB-KD	4-12	100 m6	210	180	28	90	16	M24*50	630	135	760	800	1140	224	52	35	800	770	355	1000	1940	583,5	583,5	583,5	

* 355M-355LA: terminals can't positioned on left side.

V1

B1C - B2C	Motor Type	Poles	Shaft extension							Dimensions						
			D	E	ED	F	G	GD	DH	AC	AD	L	LM ⁽¹⁾	LG		
			Left Side	Top	Right Side											
355 M-MB	2	75 m6	140	125	20	67,5	12	M20*42	735	645	1600	1690	-	415	415	
355 M-MB	4-12	100 m6	210	180	28	90	16	M24*50	735	645	1670	1760	-	485	485	
355 LA-LB	2	75 m6	140	125	20	67,5	12	M20*42	735	645	1600	1690	-	415	415	
355 LA-LB	4-12	100 m6	210	180	28	90	16	M24*50	735	645	1670	1760	-	485	485	
355 KB-KD	2	75 m6	140	125	20	67,5	12	M20*42	800	770	1840	1940	513,5	513,5	513,5	
355 KB-KD	4-12	100 m6	210	180	28	90	16	M24*50	800	770	1940	2040	583,5	583,5	583,5	

⁽¹⁾ Dimension with canopy

Motor Type	Poles	Dimensions						
		IM	LA	M	N j6	P	S	T
355 M-MB	2	B5	25	740	680	800	8*24	6
355 M-MB	4-12	B5	25	740	680	800	8*24	6
355 LA-LB	2	B5	25	740	680	800	8*24	6
355 LA-LB	4-12	B5	25	740	680	800	8*24	6
355 KB-KD	2	B5	26	740	680	800	8*24	6
355 KB-KD	4-12	B5	26	740	680	800	8*24	6

B3

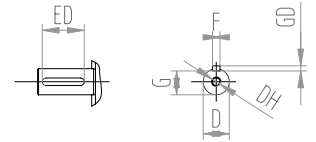
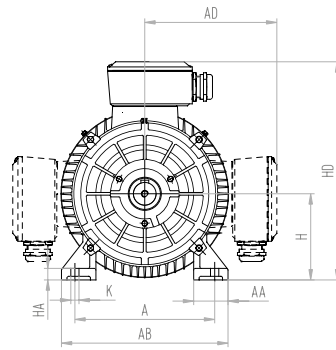
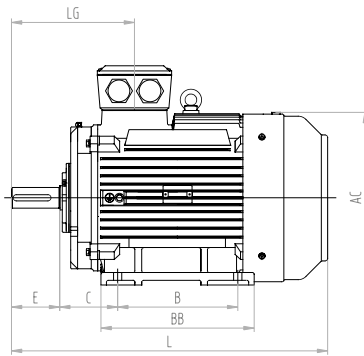

B3

Motor Type	Poles	Shaft extension							Dimensions															
		D	E	ED	F	G	GD	DH	A	AA	AB	B	BB	C	HA	K	AC	AD	H	HD	L	LG		
		Left Side	Top	Right Side																				
80 MA-MB	2-8	19 j6	40	32	6	15,5	6	M6*16	125	34	160	100	130	50	10	10	180	160	80	240	305	140	112	140
90 S	2-8	24 j6	50	40	8	20	7	M8*19	140	36	176	100	160	56	12,5	10	210	170	90	260	340	168,5	126	168,5
90 L	2-8	24 j6	50	40	8	20	7	M8*19	140	36	176	125	185	56	12,5	10	210	170	90	260	365	181	126	181
100 LA-LB	2-8	28 j6	60	50	8	24	7	M10*22	160	40	200	140	206	63	14	12	220	180	100	280	403	208	139	208
112 M	2-8	28 j6	60	50	8	24	7	M10*22	190	45	226	140	180	70	14	12	236	195	112	307	410	200	144	200
132 S-SB	2-8	38 k6	80	70	10	33	8	M12*28	216	53	262	140	200	89	16	12	275	215	132	347	485	239	167	239
132 MA-MB	2-8	38 k6	80	70	10	33	8	M12*28	216	53	262	178	238	89	16	12	275	215	132	347	525	258	167	258
160 M-MB	2-8	42 k6	110	90	12	37	8	M16*36	254	65	314	210	302	108	19	14,5	330	255	160	415	665	260	260	260
160 L	2-8	42 k6	110	90	12	37	8	M16*36	254	65	314	254	302	108	19	14,5	330	255	160	415	665	260	260	260
180 M	2-8	48 k6	110	100	14	42,5	9	M16*36	279	68	345	241	320	121	22	14,5	380	275	180	455	730	272	272	272
180 L	2-8	48 k6	110	100	14	42,5	9	M16*36	279	68	345	279	320	121	22	14,5	380	275	180	455	730	272	272	272
200 L-LB	2-8	55 m6	110	100	16	49	10	M20*42	318	78	388	305	353	133	25	18,5	420	310	200	510	790	298	298	298
225 M	2	55 m6	110	100	16	49	10	M20*42	356	75	431	311	373	149	28	18,5	465	330	225	555	865	308	308	308
225 S	4-8	60 m6	140	125	18	53	11	M20*42	356	75	431	286	348	149	28	18,5	465	330	225	555	840	338	338	338
225 M	4-8	60 m6	140	125	18	53	11	M20*42	356	75	431	311	373	149	28	18,5	465	330	225	555	865	338	338	338
250 M	2	60 m6	140	125	18	53	11	M20*42	406	100	484	349	445	168	33	24	520	375	250	625	945	357	357	357
250 M	4-8	65 m6	140	125	18	58	11	M20*42	406	100	484	349	445	168	33	24	520	375	250	625	945	357	357	357
280 S	2	65 m6	140	125	18	58	11	M20*42	457	105	546	368	485	190	35	24	570	405	280	685	990	357	357	357
280 S	4-8	75 m6	140	125	20	67,5	12	M20*42	457	105	546	368	485	190	35	24	570	405	280	685	990	357	357	357
280 M	2	65 m6	140	125	18	58	11	M20*42	457	105	546	419	536	190	35	24	570	405	280	685	1045	357	357	357
280 M	4-8	75 m6	140	125	20	67,5	12	M20*42	457	105	546	419	536	190	35	24	570	405	280	685	1045	357	357	357
315 S	2	65 m6	140	125	18	58	11	M20*42	508	122	624	406	511	216	45	28	650	490	315	805	1185	743	392	392
315 S	4-8	80 m6	170	140	22	71	14	M20*42	508	122	624	406	511	216	45	28	650	490	315	805	1215	773	422	422
315 MA	2	65 m6	140	125	18	58	11	M20*42	508	122	624	457	621	216	45	28	650	490	315	805	1295	853	392	392
315 MA	4-8	80 m6	170	140	22	71	14	M20*42	508	122	624	457	621	216	45	28	650	490	315	805	1325	883	422	422
315 MB	2	65 m6	140	125	18	58	11	M20*42	508	122	624	508	621	216	45	28	650	490	315	805	1295	853	392	392
315 MC	4-8	80 m6	170	140	22	71	14	M20*42	508	122	624	508	621	216	45	28	650	490	315	805	1325	883	422	422
*355 M-MB	2	75 m6	140	125	20	67,5	12	M20*42	610	120	730	560	850	254	50	28	735	645	355	1000	1620	-	415	415
*355 M-MB	4-8	100 m6	210	180	28	90	16	M24*50	610	120	730	560	850	254	50	28	735	645	355	1000	1690	-	485	485
*355 LA-LB	2	75 m6	140	125	20	67,5	12	M20*42	610	120	730	630	850	254	50	28	735	645	355	1000	1620	-	415	415
*355 LA-LB	4-8	100 m6	210	180	28	90	16	M24*50	610	120	730	630	850	254	50	28	735	645	355	1000	1690	-	485	485

* 355 M-355 LA: terminals can't positioned on left side.

B5-V1

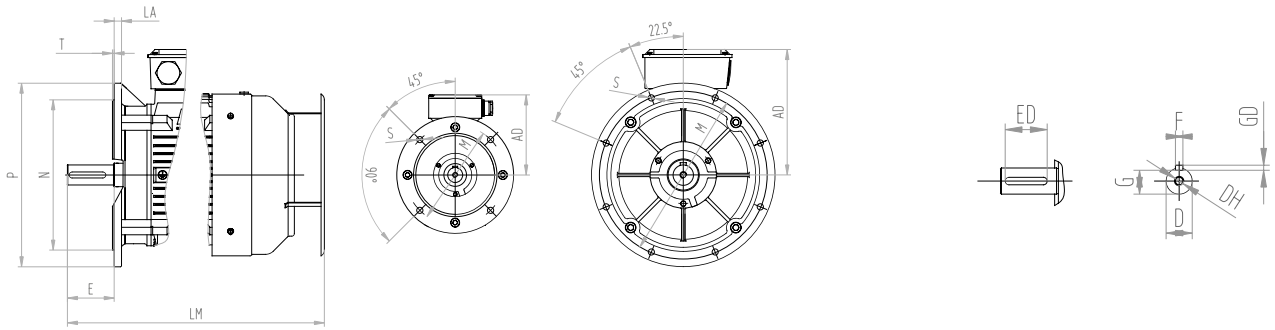

B14

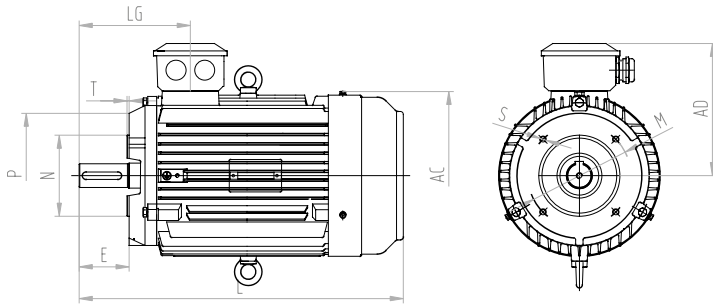

B5-V1 / B14

Motor Type	Poles	Shaft extension							Dimensions						
		D	E	ED	F	G	GD	DH	AC	AD	L	LM ⁽¹⁾	LG		
		Left Side	Top	Right Side											
80 MA-MB	2-8	19 j6	40	32	6	15,5	6	M6*16	180	160	305	345	140	112	140
90S/L	2-8	24 j6	50	40	8	20	7	M8*19	210	170	340	380	168,5	126	168,5
		24 j6	50	40	8	20	7	M8*19	210	170	365	405	181	126	181
100 LA-LB	2-8	28 j6	60	50	8	24	7	M10*22	220	180	403	450	208	139	208
112 M-MA	2-8	28 j6	60	50	8	24	7	M10*22	236	195	410	460	200	144	200
132 S-SB	2-8	38 k6	80	70	10	33	8	M12*28	275	215	485	535	239	167	239
132 MA-MB		38 k6	80	70	10	33	8	M12*28	275	215	525	575	258	167	258
160 M-MB	2-8	42 k6	110	90	12	37	8	M16*36	330	255	665	720	260	260	260
160 L		42 k6	110	90	12	37	8	M16*36	330	255	665	720	260	260	260
180M/L	2-8	48 k6	110	100	14	42,5	9	M16*36	380	275	730	785	272	272	272
		48 k6	110	100	14	42,5	9	M16*36	380	275	730	785	272	272	272
200 L-LB	2-8	55 m6	110	100	16	49	10	M20*42	420	310	790	860	298	298	298
225 M	2	55 m6	110	100	16	49	10	M20*42	465	330	865	935	308	308	308
225 S	4-8	60 m6	140	125	18	53	11	M20*42	465	330	840	910	338	338	338
225 M	4-8	60 m6	140	125	18	53	11	M20*42	465	330	865	935	338	338	338
250 M	2	60 m6	140	125	18	53	11	M20*42	520	375	945	1025	357	357	357
250 M	4-8	65 m6	140	125	18	58	11	M20*42	520	375	945	1025	357	357	357
280 S	2	65 m6	140	125	18	58	11	M20*42	570	405	990	1080	357	357	357
280 S	4-8	75 m6	140	125	20	67,5	12	M20*42	570	405	990	1080	357	357	357
280 M	2	65 m6	140	125	18	58	11	M20*42	570	405	1045	1125	357	357	357
280 M	4-8	75 m6	140	125	20	67,5	12	M20*42	570	405	1045	1125	357	357	357
315 S	2	65 m6	140	125	18	58	11	M20*42	650	490	1185	1285	743	392	392
315 S	4-8	80 m6	170	140	22	71	14	M20*42	650	490	1215	1315	773	422	422
315 MA	2	65 m6	140	125	18	58	11	M20*42	650	490	1295	1395	853	392	392
315 MA	4-8	80 m6	170	140	22	71	14	M20*42	650	490	1325	1425	883	422	422
315 MB	2	65 m6	140	125	18	58	11	M20*42	650	490	1295	1395	853	392	392
315 MB	4-8	80 m6	170	140	22	71	14	M20*42	650	490	1325	1425	883	422	422
355 M-MB	2	75 m6	140	125	20	67,5	12	M20*42	735	645	1620	1720	-	415	415
355 M-MB	4-8	100 m6	210	180	28	90	16	M24*50	735	645	1690	1790	-	485	485
355 LA-LB	2	75 m6	140	125	20	67,5	12	M20*42	735	645	1620	1720	-	415	415
355 LA-LB	4-8	100 m6	210	180	28	90	16	M24*50	735	645	1690	1790	-	485	485

Motor Type	Poles	Dimensions						
		IM	LA	M	Nj6	P	S	T
80 MA-MB	2-8	B5	12	165	130	200	4*12	3,5
		B14	-	100	80	120	4*M6	3
90S/L	2-8	B5	12	165	130	200	4*12	3,5
		B14	-	115	95	140	4*M8	3
100 LA-LB	2-8	B5	14	215	180	250	4*14,5	4
		B14	-	130	110	160	4*M8	3,5
112 M-MA	2-8	B5	14	215	180	250	4*14,5	4
		B14	-	130	110	160	4*M8	3,5
132 S-SB	2-8	B5	14	265	230	300	4*14,5	4
132 MA-MB		B14	-	165	130	200	4*M10	3,5
160 M-MB	2-8	B5	15	300	250	350	4*18,5	5
160 L		B14	-	215	180	250	4*M12	4
180M/L	2-8	B5	15	300	250	350	4*18,5	5
		B14	-	215	180	250	4*M12	4
200 L-LB	2-8	B5	17	350	300	400	4*18,5	5
225 M	2	B5	19	400	350	450	8*18,5	5
225 S	4-8	B5	19	400	350	450	8*18,5	5
225 M	4-8	B5	19	400	350	450	8*18,5	5
250 M	2	B5	22	500	450	550	8*18,5	5
250 M	4-8	B5	22	500	450	550	8*18,5	5
280 S	2	B5	22	500	450	550	8*18,5	5
280 S	4-8	B5	22	500	450	550	8*18,5	5
280 M	2	B5	22	500	450	550	8*18,5	5
280 M	4-8	B5	22	500	450	550	8*18,5	5
315 S	2	B5	24	600	550	660	8*24	6
315 S	4-8	B5	24	600	550	660	8*24	6
315 MA	2	B5	24	600	550	660	8*24	6
315 MA	4-8	B5	24	600	550	660	8*24	6
315 MB	2	B5	24	600	550	660	8*24	6
315 MB	4-8	B5	24	600	550	660	8*24	6
355 M-MB	2	B5	25	740	680	800	8*24	6
355 M-MB	4-8	B5	25	740	680	800	8*24	6
355 LA-LB	2	B5	25	740	680	800	8*24	6
355 LA-LB	4-8	B5	25	740	680	800	8*24	6

⁽¹⁾ Dimension with canopy. For B5 mounting consider dimension "L".

B3

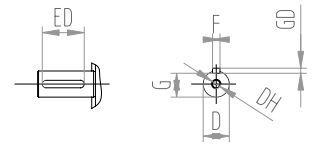
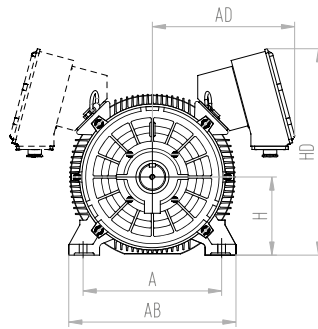
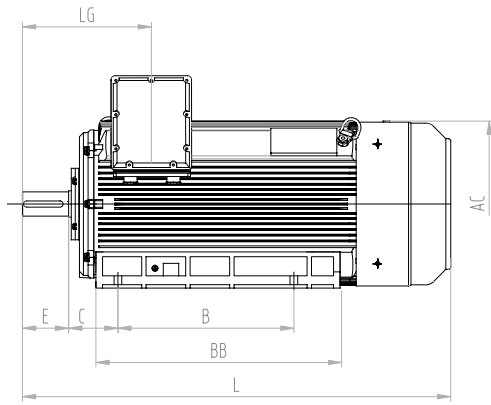

V1

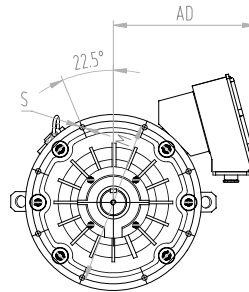
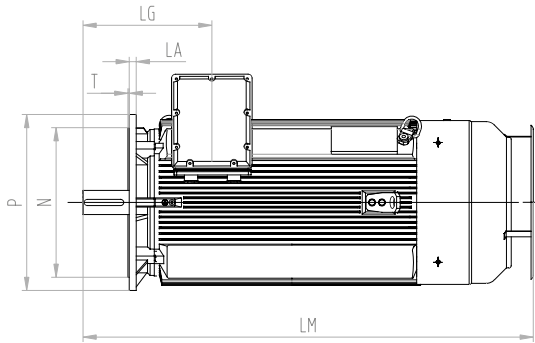

B3

B3C	Motor Type	Poles	Shaft extension							Dimensions															
			D	E	ED	F	G	GD	DH	A	AA	AB	B	BB	C	HA	K	AC	AD	H	HD	L	LG		
			Left Side	Top	Right Side																				
355 KB-KD	2	75 m6	140	125	20	67,5	12	M20*42	630	135	760	800	1140	224	52	35	800	770	355	1000	1840	513,5	513,5	513,5	
355 KB-KD	4-8	100 m6	210	180	28	90	16	M24*50	630	135	760	800	1140	224	52	35	800	770	355	1000	1940	583,5	583,5	583,5	

V1

B3C	Motor Type	Poles	Shaft extension							Dimensions						
			D	E	ED	F	G	GD	DH	AC	AD	L	LM ⁽¹⁾	LG		
			Left Side	Top	Right Side											
355 KB-KD	2	75 m6	140	125	20	67,5	12	M20*42	800	770	1840	1940	472	472	472	
355 KB-KD	4-8	100 m6	210	180	28	90	16	M24*50	800	770	1940	2040	512	512	512	

Motor Type	Poles	Dimensions						
		IM	LA	M	N j6	P	S	T
355KB-KD	2	B5	26	740	680	800	8*24	6
355 KB-KD	4-8	B5	26	740	680	800	8*24	6

⁽¹⁾ Dimension with canopy