

Exceeding expectations.

Those two words sum up our company... but we would like to tell you a bit more.

Hoyer is founded on the knowledge that our business partners have high standards, and even higher expectations of their suppliers. It is our job not just to meet those expectations, but to exceed them.

Let's show you our world of electric motors, and explain how we add value by challenging your expectations of what a partnership can be.

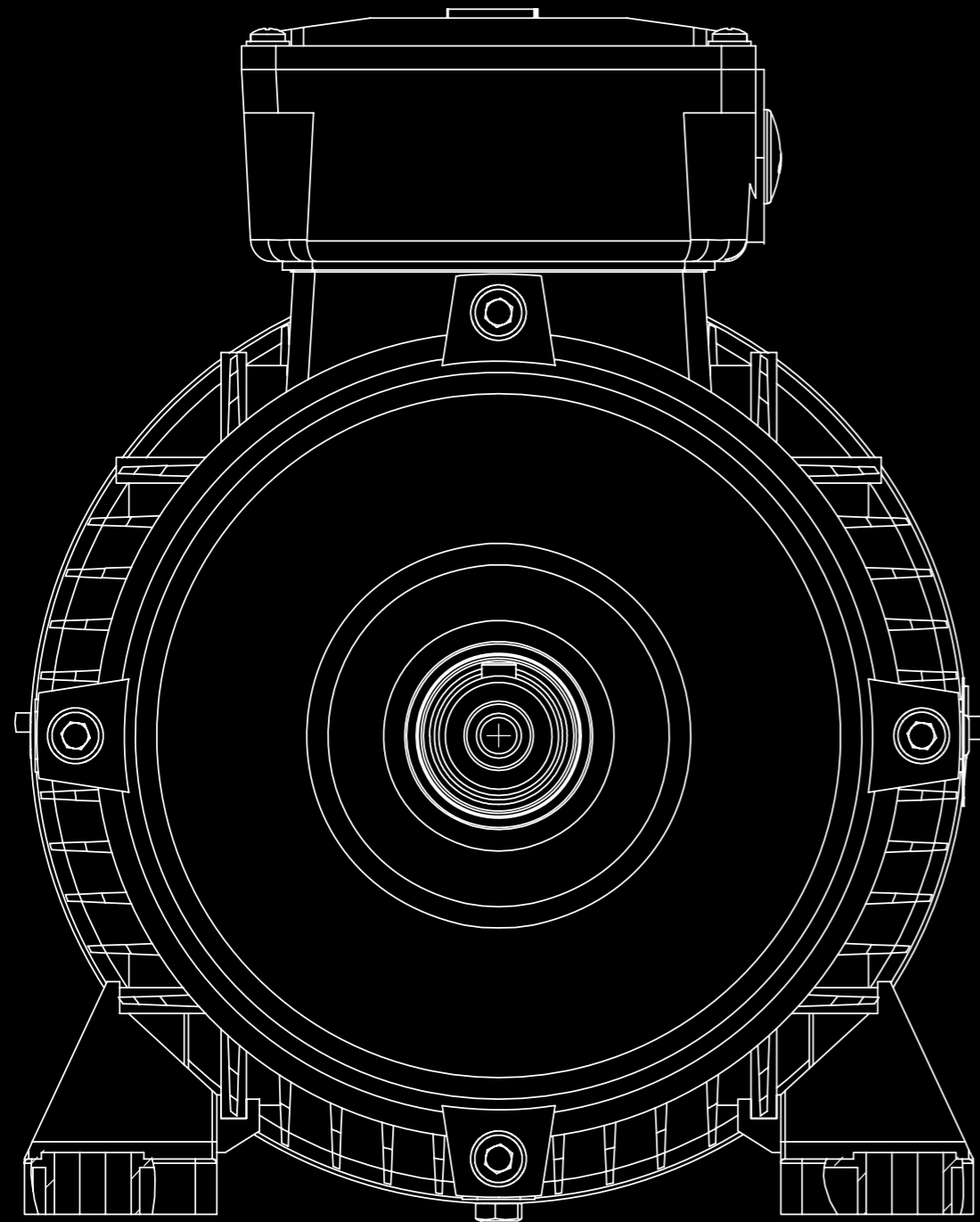

History & Experience

Founded in Denmark more than 40 years ago, we have a deep understanding of electric motors and the industries where they are used. While the basic principles of the technology might not have changed much in that time, product performance, documentation and service have.

Today, we believe our extensive experience sets us apart while our focus on customers' needs has helped us earn some of the longest partnerships in the industry.

Our deep understanding of the market and your needs is reflected in our flexible service and our global presence. Wherever your company or project is located, you'll find us close at hand with the same product programme and service set-up, and the same readiness to assist you in every possible way.

Today, our Danish heritage is still reflected in our corporate culture where honesty, reliability and openness shape the way we do business.

Segments

005

Marine

The marine segment is our largest. Our focus on service, delivery performance, flexibility, and ability to ensure the right product-fit has made us a leading player in the segment. That approach has earned us the trust of world-class OEMs, leading shipowners and aftermarket distributors.



006

Water & Wastewater



We have long cooperated with OEMs within Water & Wastewater and those relationships have shaped our company and approach to motors. Pumps is the largest application group across our segments and we have a deep understanding of what it takes to make a difference.

VESSEL TYPES

APPLICATIONS

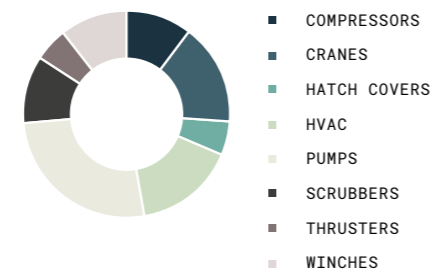
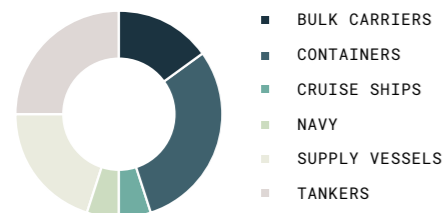

TOP INDUSTRIES

APPLICATIONS

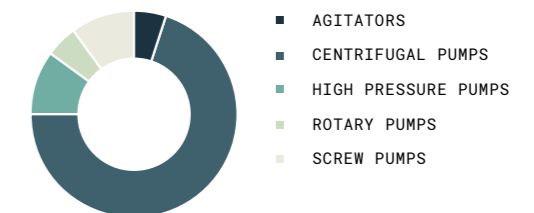
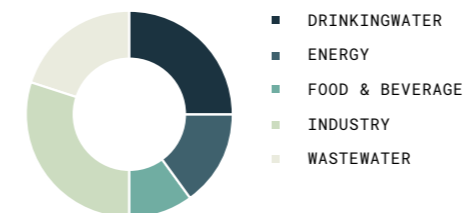

007

HVAC



The motor is essential to all HVAC applications - and finding the perfect motor fit is critical. We understand that the ideal balance between quality, costs and performance is key to making a difference as supplier.

TOP INDUSTRIES

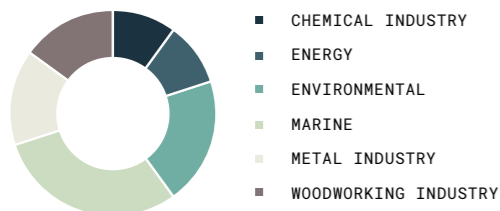

APPLICATIONS

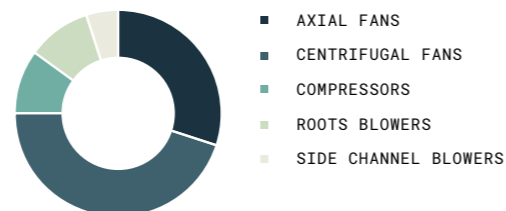

008

HPU



In recent years we have become experts in motor solutions for hydraulic power units. We understand that in the hydraulic market, different solutions will be required depending on the purpose and usage of the HPU. Not only do we understand our customers' products, we also have extensive insight into their customers' applications.

TOP INDUSTRIES

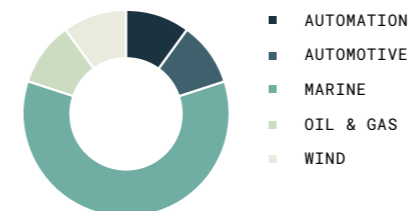

APPLICATIONS

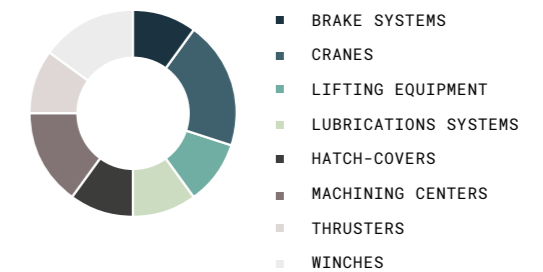

009

Oil & Gas



While still relatively new to the Oil & Gas industry, our comparatively recent entry into the energy segment has advantages as it allows us to challenge our customers' approach to electric motors.

010

Wind

Our Wind customers are under constant pressure to cut costs while fulfilling demanding standards. Our solutions are designed to help meet these challenges by finding the perfect product fit while ensuring market-leading delivery performance.



OFFSHORE VESSEL TYPES

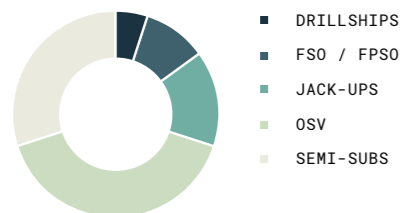

APPLICATIONS

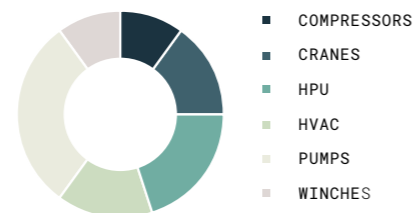

TURBINES

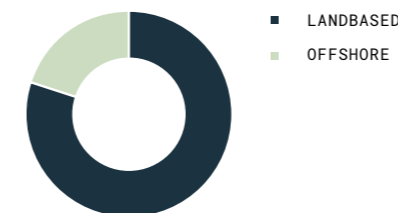

APPLICATIONS

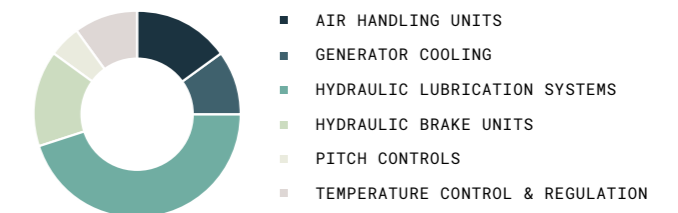



How we
add value

013

Service & flexibility

Service is in our DNA. You can expect an extremely fast response time, customised solutions, and a deep understanding of the industries we serve. No matter who we're dealing with, no matter which product or solution, and no matter which segment, we're determined to provide a level of service that will inspire maximum confidence among our customers.

At Hoyer, we always design service solutions around our customers' business model. This means that you should prepare to be challenged as we like to ask questions!

Great service is seen as an integral element of our products. And we believe it's what differentiates us from our competitors. By responding fast, providing customised solutions, and through a deep understanding of our segments, we can make a meaningful difference to your bottom line.

- Guaranteed response within 24 hours
- Customised setups
- Proactive approach
- Solution-oriented

014

Delivery performance & lead time

We understand the importance of minimising stock expenses while still ensuring a steady production flow and project flexibility. That's why we take such pride in our 98% delivery performance and ability to minimise lead times.



Delays are bad for business, with penalties, additional production costs and damaged relations all harming your bottom line. Our first priority is helping your business reach its performance goals on time and improve its order win-rate by ensuring short lead times.

- Close partnerships and shared forecasting
- Workshop and modifications
- Extensive warehouse facilities
- Customised logistics solutions

Quality

Quality depends on the understanding that every detail is essential to a great product. We continually optimise our products, internal systems, processes and procedures to make sure that our solutions remain best-in-class.

You'll notice our attention to detail straightaway – and not just in our products. Knowing that you can count on what we deliver, and how we deliver it, you're free to focus 100% on your core business.

While we can't say that our products run forever, errors and nonconformities are extremely rare. When they do occur, procedures and systems are in place to quickly identify the cause, correct the error, and initiate and verify corrective actions.

- Integrated Management System focusing on quality and HSE
- Constant focus on meeting customer needs and understanding of their risks and opportunities
- Non-conformance system builds on the 8D terminology and is integrated in the ERP system
- Constant focus on exceeding targets

Documentation and approvals

Our reputation depends on our credibility so reliable documentation is a natural part of our operations. Full-scale data packages are essential for many of our customers' ability to stay ahead of their competition. But because we know one size does not fit all, we offer a wide range of options.

We view documentation not just as a technical matter but also as a competitive resource we can pass on to the benefit of our business partners.

In addition to type tests, drawings, and declarations, our documentation includes procedures, marine classification certificates and internal performance management, and much more.

- Online access to data and documentation

- Customised documentation packages

- In-house testing centres

- Partnerships with all major authorities and class societies

Logistics and warehousing

With large-scale warehousing facilities in Denmark and China, we offer short lead times in all markets. As experts in logistics solutions, it could be said that we function as our customers' warehouse. But this expertise also plays a key role in regards to quality assurance.

Our warehouse setup is one of the cornerstones of our company. In the course of handling thousands of containers each year, our quality assurance team play a key role inspecting incoming and outgoing goods.

We never ship directly from our production sites to our business partners for the simple reason that we believe in the greatest possible level of control and testing to minimise errors. Some may see it as time-consuming but we see it as an essential way to ensure peace of mind for our customers.

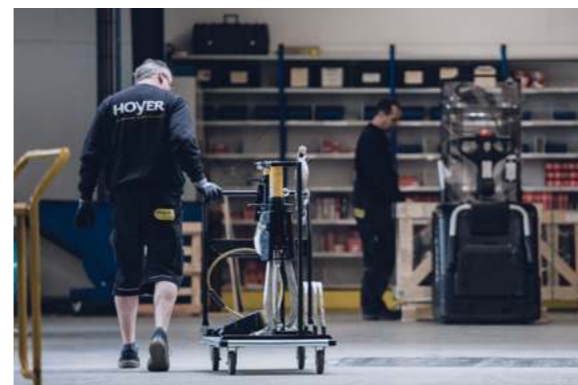

019

Customisation workshops

Our high-end workshops have two overall objectives. Firstly, to rebuild and customise standard motors according to our customers' needs, and secondly to ensure a flexible inventory in case of unforeseen events and projects.

For project-based customers, our workshops have a proven positive impact on their win-rate.

Types of customisation carried out in our workshops

- Anti condensation heaters
- Tropical windings
- Customised nameplates
- Protection class IP56, IP65, IP 66 and for open deck mounting
- Current-insulated bearings and other special bearings
- SPM – shock pulse measuring
- Forced fan cooling and TENV – totally enclosed non ventilated
- Explosion class II 3G Ex nA IIC T3/II 3D Ex tc IIIB T120

020

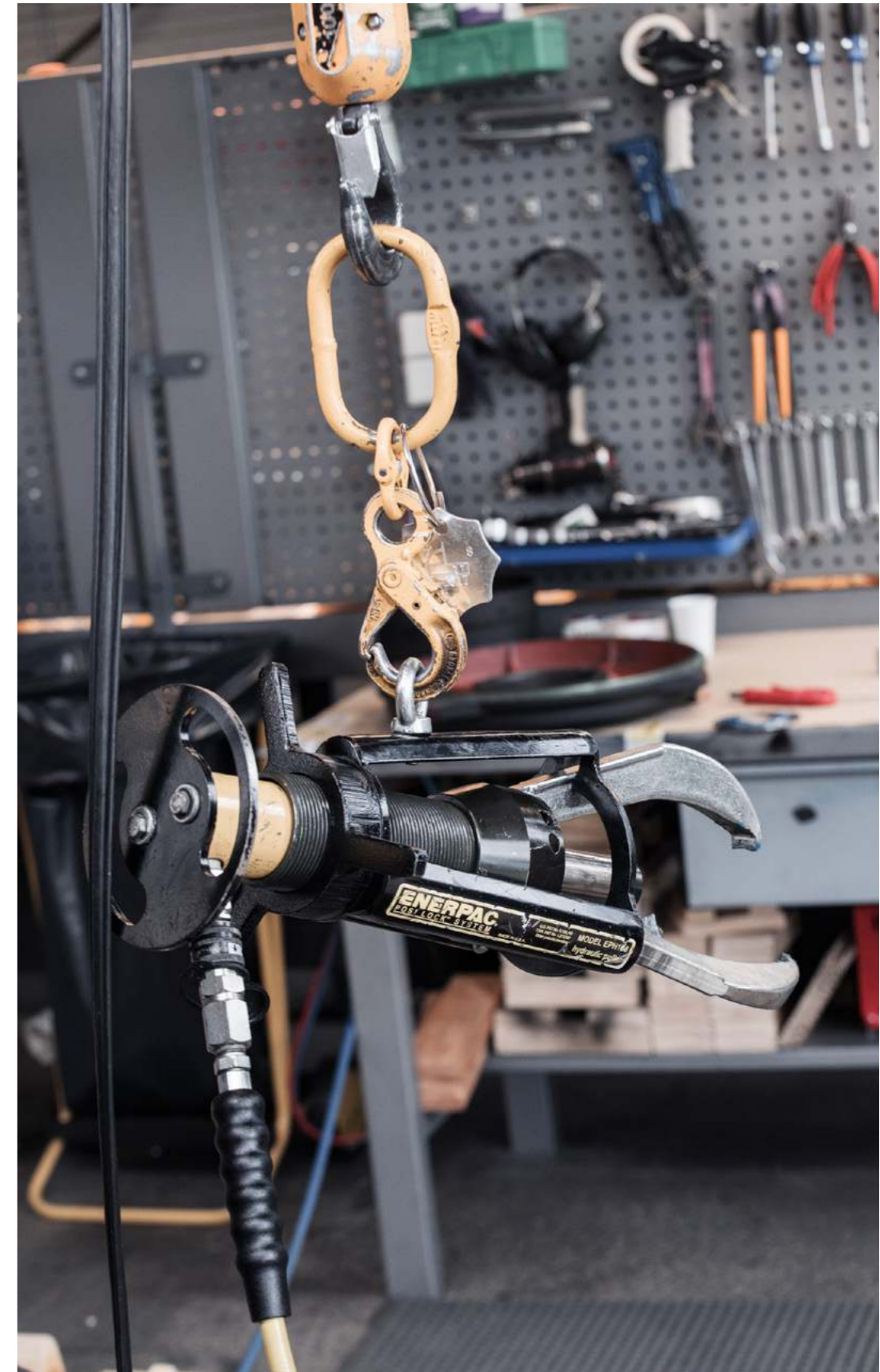

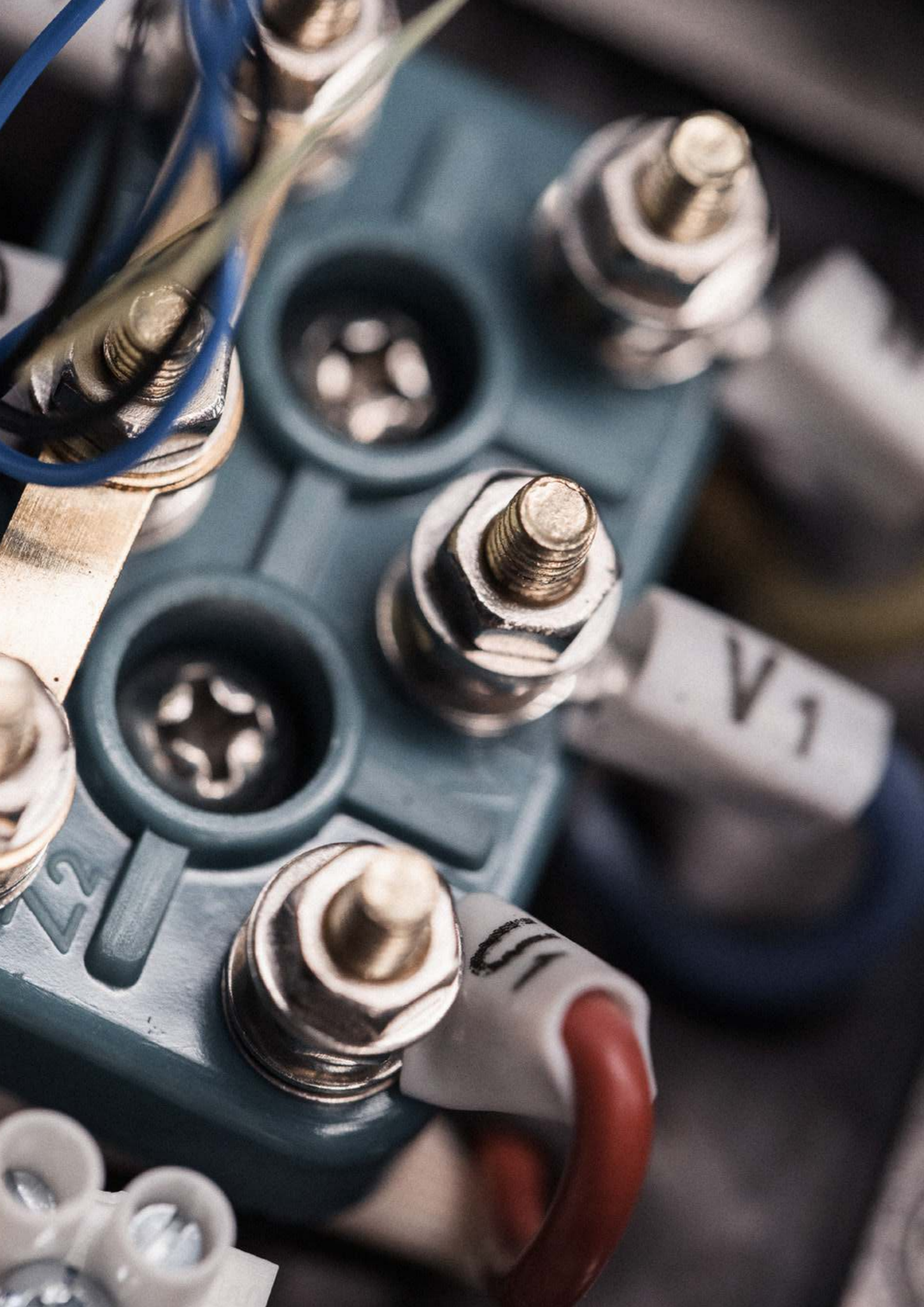

Our testing centres

Our testing centres are designed to handle on-demand testing of our motors. Without involving third party test centres, we are able to perform various tests according to IEC 600034-2-1 on a day-to-day basis.

In case of special testing requests or classification of non-tested motors, our customers are guaranteed a flexible and cost-efficient testing process. For our Marine and Oil & Gas segments, this is backed up by a strong collaboration with class societies and their teams of surveyors.

Selected tests performed in our testing centres

- Winding resistance
- Locked rotor test
- Temperature rise test
- Full load test
- Over load test
- No load test
- Noise and vibration tests

Product Overview

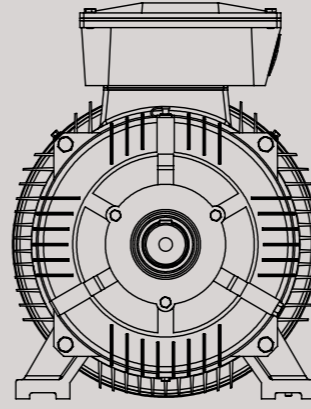

Industrial Motors

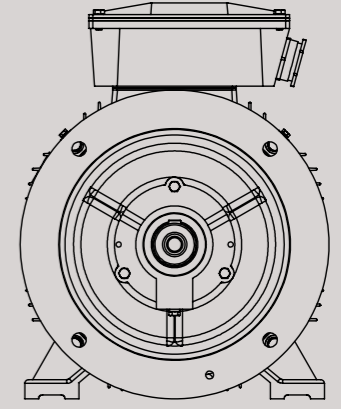

Marine Motors

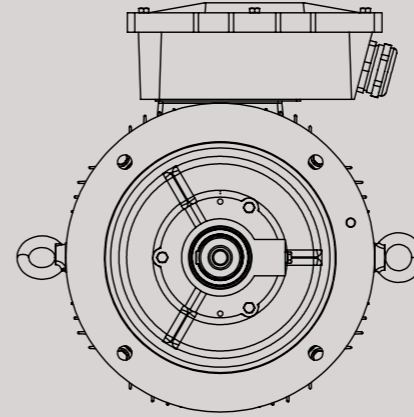

Marine Brake Motors

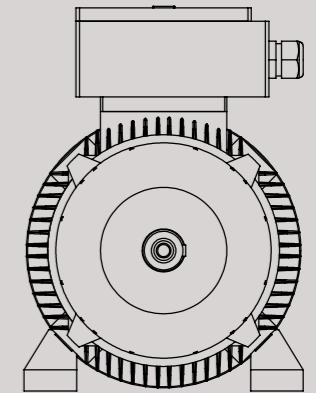

Explosion Proof Motors

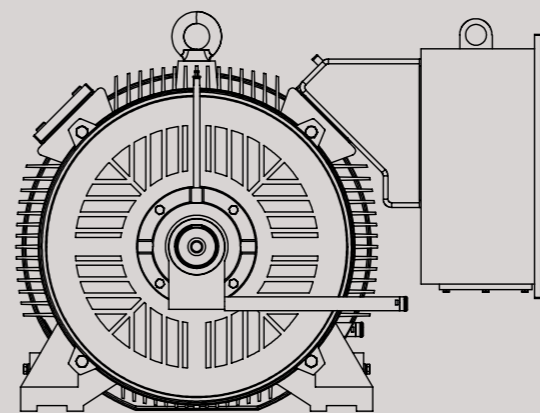

Medium Voltage Motors

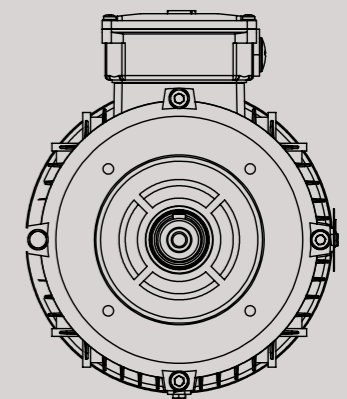

Wind Motors

025 Industrial Motors

Frame size
56-560

Output
0,09-1800 kW

Marine Motors

Frame size
56-560

Output
0,09-1800 kW

Marine Brake Motors

Frame size
132-355

Output
6,4-415 kW

Explosion Proof Motors

Frame size
71-315

Output
0,09-200 kW

Medium Voltage Motors

Frame size
355-560

Output
185-1800 kW

Wind Motors

Frame size
56-200

Output
0,09-37 kW