

Explosion Proof

IE2 Marine Motors

hoyermotors.com

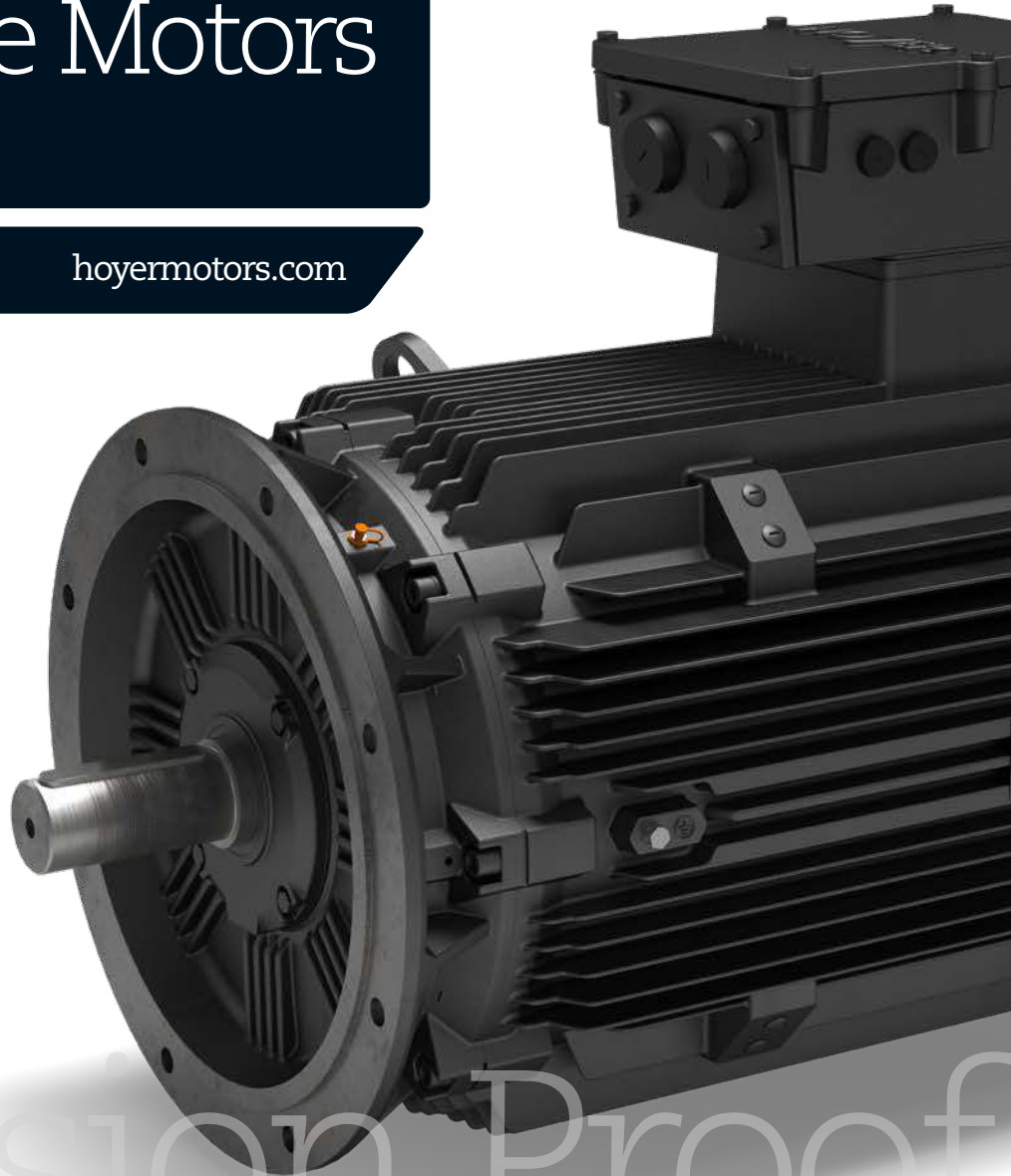

Explosion Proof

HOYER
MOTORS



HOYER

EXCEEDING EXPECTATIONS

Hoyer Motors is an international supplier of high-end electric motors. Headquartered in Denmark and China, we are represented through sales offices and distributors worldwide. We pride ourselves of being an elite manufacturing enterprise with the highest attention to service and flexibility – a company where dedication, competitiveness and reliability are second to none.

We have selected focus on the segments Marine, HVAC, Industrial Pumps, Oil & Gas, Wind and HPU. Through strong partnerships with market leading industrial OEM's within these segments, we are able to offer a unique setup and industrial insight. We add value by understanding the business and markets of our customers.

At Hoyer Motors, meeting agreements is as natural as breathing air. We believe in trustworthy partnerships with our customers and always meet our obligations on deliveries, documentation and product quality. This is what we mean by Exceeding Expectations.

General information

The Hoyer Motors explosion proof marine range type HMCX is distinguished by high material quality, robust design, high index of IP protection, weather and corrosion resistant coating and high dielectric strength insulation system ready for frequency converter duty. The standard design features are seen below.

Product information	
Series:	HMCX IEC size 80-355 grey cast iron housing with cooling ribs, terminal box and bearing shield
Standards:	IEC / EN 60079-0, 60079-1, 60079-7
Cooling:	IC411 (TEFC)
Ex protection:	ATEX: II 2G Ex db eb IIB T4 Gb IECEX: Ex db eb IIB T4 Gb Housing enclosure 'db' and terminal box 'eb'
Mounting form:	B3, B5, B35, V1
Terminal box:	Terminal box on top. Other positions on request
Power range:	0.37 - 315 kW
Duty:	S1, S2-S10 on request
Ambient temperature:	For direct on line (DOL) operation -20°C to +45°C. -40°C to +60°C on request
Altitude:	Up to 1000m above sea level. Higher altitude on request
Voltage at 50Hz:	230/400V Δ/Y (Up to 3 kW), 400/690V Δ/Y (Above 3 kW) at 50Hz. Supply variations according IEC 60034-1. Other voltages on request
Voltage at 60Hz:	280/440V, 480V Δ/Y (Up to 3kW), 440, 480/830V Δ/Y (Above 3kW) at 60Hz. Supply variations according IEC 60034-1. Other voltages on request
Frequency range:	30-60Hz for quadratic and constant torque. 5-100Hz and constant torque on request
Efficiency:	IE2 according to IEC 60034-30. IE3 on request
Numbers of poles:	2,4,6 and 8 as standard. 10-16 on request
Protection class:	IP55, IP56, IP65 and IP66 on request
Insulation class / temperature rise:	F / B. Insulation class H on request
Coating:	Hoyer standard, C3L. Other coatings on request
Colour:	RAL 9005. Other colors on request
Heater:	220-240V heater in windings as standard
Winding protection:	3xPTC 145°C
Blind plugs:	ATEX / IECEX certified. Cable glands on request
Winding coating:	Tropical insulated
Power supply:	DOL or frequency converter duty (VFD)

Hoyer IE2 Marine Ex Motors

Options

- Other mounting arrangements
- PT100 in windings
- PT100 in bearings
- SPM nipple in bearing shields
- Special flanges
- Other surface treatments and/or special chemical resistant coatings
- Rain cover
- Cylindrical roller bearings and angular contact ball bearings
- Current insulated bearings for VFD duty
- Frequency converter driven motor within range of 5-100 Hz

Open deck design option

Open deck applications are often directly exposed to the harsh marine environment. A special HMCX design is developed to meet the tough demands of open deck operation.

Design

- V1 mounted motors
- Special open deck rain cover
- IP66 protection
- IP66 open deck terminal box
- Terminal box in non-drive end. Downwards pointing cable entries

Options

- Option for IP67 in stand still condition
- Option for other mounting forms



Documentation

The HMCX is designed according to IEC 60079-0, IEC 60079-1, EN 60079-7:2015/A1. The full list of national and international standards can be seen below.

National and international standards

GB	3836.1, 3836.2, 3836.3
IEC	60079-0, 60079-1, 60079-7
EN	60079-0, 60079-1, 60079-7/A1

Motors of series HMCX are certified in conformity with the latest edition of IEC and European standards.

Protection classes

The protection classes for gasses and vapour covered by the Hoyer HMCX standard range is found below.

	Group	Device category	Appearance frequency of ex. atmosphere	Zone	Type of protection	Temp. class	Index of mech. protection	Motor type
Grease and Vapour (G)	II	2G	Frequently	1	Ex db IIB Gb	T4	Standard: IP55 On request: IP56, IP65, IP66	HMCX Size 80-355
					Ex db IIC Gb			
					Ex db eb IIB Gb			
					Ex db eb IIC Gb			

Motors designed in protection enclosure 'db' can be used in zone 1 explosive atmospheres, group of use II (all industry except mining). In these areas such an atmosphere can occur during normal operation (zone 1). An explosive atmosphere is a mixture of flammable substances and air in the form of gas and vapour. Dangerous zones in the marine and oil & gas industries occurs on many vessel and platform types including gas carriers, semi-sub, tankers, FPSO's, FSO's, FLNG's, FSRU's etc.

Conditions must be divided in danger zones, defined by the end-user in cooperation with appropriate establishments, according to frequency and duration of appearance of an explosive gas atmosphere (Zone 1).

Notified body CNEx



Certificate number

CNEX 19 ATEX 0028 X
IECEX CNEX 19.0019X

Hoyer IE2 Marine Ex Motors

Type and designation HMCX range

Below overview is applicable for the HMCX motor range:

	HM	C	X	355	M	1	-	4
Hoyer Motor								
Cast Iron								
Explosion proof								
Frame size								
Length of frame								
Length of iron core								
Pole number								

Motor manual HMCX range

An English HMCX motor manual is supplied as standard with all motors. Please be aware that only qualified personnel as per IEC 60079-17, EN 50110-1/-2 (VE 0105, part 100) and Directive 99/92/EC is allowed to work on explosion proof motors. Repair in compliance with the values in Table 1 and 2 of EN 60079-1 is not allowed.

Marine classification

Through close cooperation with all major class societies and in-house test facilities Hoyer Motors offers a flexible documentation package developed specifically for the marine industry.



Bearings and blind plugs

Hoyer HMCX range comes with premium quality bearings. The motors are as standard equipped with single-row deep groove ball bearings and locked in D.E. Angular contact bearings and cylindrical roller bearings bearings in D.E. are available on request.

Frame size 80-250 comes with closed bearings greased for life.

Frame size 250-355 comes with re-greaseable open bearings.

Bearing grease in temperature range $-20^{\circ}\text{C}/+175^{\circ}\text{C}$ is used in both closed and open bearings.

As standard all motors are equipped with blind plugs. Cable glands for hazardous areas are available on request.

Bearings

Motor type	Drive end		None drive end	
	2 pole	4,6,8 pole	2 pole	4,6,8 pole
HMCX 80	6204-2Z		6204-2Z	
HMCX 90	6205-2Z		6203-2Z	
HMCX 100	6206-2Z		6205-2Z	
HMCX 112	6206-2Z		6206-2Z	
HMCX 132	6208-2Z		6305-2Z	
HMCX 160	6309-2Z		6307-2Z	
HMCX 180	6310-2Z		6308-2Z	
HMCX 200	6312-2Z		6212-2Z	
HMCX 225	6312-2Z	6313-2Z	6312-2Z	
HMCX 250	6313-2Z	6314-2Z	6313-2Z	
HMCX 280	6314/C3	6317/C3	6314/C3	
HMCX 315	6316/C3	6319/C3	6316/C3	6319/C3
HMCX 355	6318/C3	6322/C3	6318/C3	6322/C3

Blind plugs

Motor type	Main blind caps	Auxiliary blind caps
HMCX 80	1 x M25X1.5	2 x M20X1.5
HMCX 90	1 x M25X1.5	2 x M20X1.5
HMCX 100	1 x M25X1.5	2 x M20X1.5
HMCX 112	1 x M25X1.5	2 x M20X1.5
HMCX 132	2 x M32X1.5	2 x M20X1.5
HMCX 160	2 x M32X1.5	2 x M20X1.5
HMCX 180	2 x M50X1.5	2 x M20X1.5
HMCX 200	2 x M50X1.5	2 x M20X1.5
HMCX 225	2 x M50X1.5	2 x M20X1.5
HMCX 250	2 x M63X1.5	2 x M20X1.5
HMCX 280	2 x M63X1.5	2 x M20X1.5
HMCX 315	2 x M63X1.5	2 x M20X1.5
HMCX 355	2 x M75X2.0	2 x M20X1.5

Supply by frequency converter

HMCX motor range is designed and tested in accordance with IEC 60034-1. It is as standard prepared for frequency converter (VFD) duty, within a regulation range between 30 to 60 Hz for quadratic and constant torque. An optional regulation between 5 to 100 Hz and constant torque is available on request. The ambient temperature for VFD operation is limited to -40°C to $+50^{\circ}\text{C}$. Motor characteristics in operation at various frequencies are defined in an additional VFD rating plate.

When supplied by VFD, the quality of variable frequency power supply ratings below should be respected:

- Switching frequency: $\geq 2000\text{Hz}$
- Total harmonic distortion (THD): $\leq 0.968\%$
- Inverter output du/dt : $\leq 1500\text{V}/\mu\text{s}$

For VFD operation and for duty types other than S1, the motor temperature shall be monitored by the PTC and optional PT100 in the stator windings. The devices must be connected to suitable tripping units that have been functionally tested for this exact purpose.

Together with Hoyer Drives & Controls complete motor and VFD solutions are offered for installation in hazardous areas.

Hoyer IE2 Marine Ex Motors

Rating plates

There is a clear “Ex” mark on the HMCX name plates and it includes below marking.

	<u>Ex</u>	<u>db</u>	<u>eb</u>	<u>IIB</u>	<u>T4</u>	<u>Gb</u>
Explosions Protected						
Type of protection for Frame						
Type of protection for Terminal box						
Gas Group						
Temperature Class Gas						
Equipment Protection Level						

Name plate

HOYER
www.hoyermotors.com

3~Mot.: HMCX 315L-4			N*: SHxxxx-xx			1290 Kg
Code:		IC 411	Tropical windings			IM. V1
CL. 155(F)	Rise. B	IP 55	Ta. 45 °C	Lp:78dB(A)	Duty S 1	
V.Δ/Y	Hz	kW	S.F	A.Δ/Y	Cos φ	rpm
400/690	50	185	1.0	309/178	0.91	1488
Δ380	50	185	1.0	Δ325	0.91	1487
Δ440	60	203.5	1.1	Δ306	0.92	1786
IE2 eff. at: 400 V 50 Hz 1/1:95.1% 3/4:95.3% 1/2:95.2%						
D.E: 6319 C3			N.D.E: 6319 C3			
YY/WW:		3PTC T145		IEC/EN 60034		
CNEX 19 ATEX 0028X			IECEx CNEX 19.0019X			
		II2G Ex db eb IIB T4 Gb				
Svend Hoyer A/S DK- 8370 Hadsten, Denmark						

VFD name plate

HOYER
www.hoyermotors.com

3~Mot.: HMCX 315L-4			N*: SHxxxx-xx			1290 Kg
Code:						IM. V1
Ta. 45°C	IC 411	IP 55		CL. F	Rise. B	Duty S 1
V.Δ/Y	Hz	kW	S.F	A.Δ/Y	Nm	rpm
D 240	30	111	1.0	D 310	1188	887
D 320	40	148	1.0	D 307	1188	1187
D 400	50	185	1.0	D 309	1188	1488
D 400	60	185	1.0	D 305	990	1784
D 440	60	203.5	1.1	D 306	1088	1786
INVERTER FEEDING (FOR VSD)						
YY/WW:		3PTC T145		IEC/EN 60034		
Svend Hoyer A/S DK- 8370 Hadsten, Denmark						

Rating tables

Rating factors for power output kW at different ambient temperatures and altitudes are found below. Motors for ambient temperatures above 45°C and altitudes above 1000 m are available on request.

Ambient temperature

Ambient temperature °C	40°	45°	50°	55°	60°
Factor (kW)	1	1	1	1	1

Altitude

Altitude m	1000 m	1500 m	2000 m	3000 m	3500 m	4000 m
Factor (kW)	1	0,96	0,92	0,88	0,84	0,76

Mounting Positions

The basic mounting arrangements of the motors are IMB3, IMB35, IMB5 and IMV1. Other special mounting arrangements are available on request.

B3

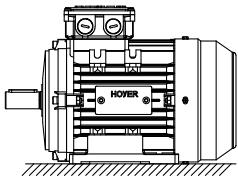

B6 *

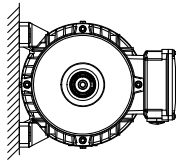

B7 *

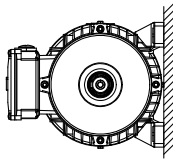

B8 *

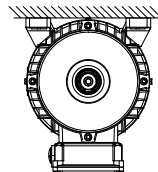

V5 *

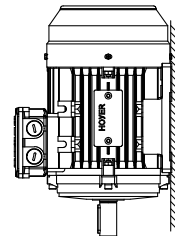

V6 *

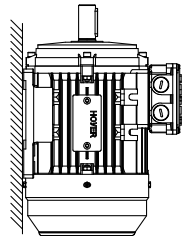

B5

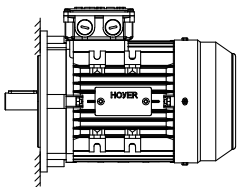

V1

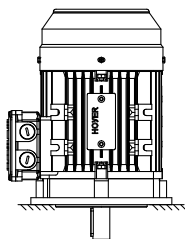

V3 *

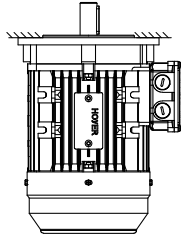

B35

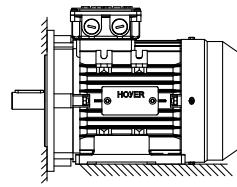

V15 *

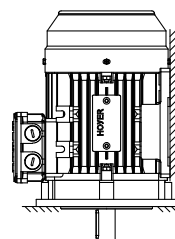

V35 *

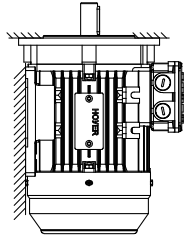

* Available on request

IE2 / 2 pole Marine Ex

Motor type	440V 60Hz S1-45°C			380V 50Hz S1-45°C			400V 50Hz S1-45°C			I _s /I _N	Efficiency (%)			Pf cos φ	Torque			IM J(kgm ²)	Weight kg
	P2	Speed	I _N	P2	Speed	I _N	P2	Speed	I _N		¹ / ₁ load	³ / ₄ load	¹ / ₂ load		T _N	T _s / T _N	T _M / T _N		
	kW	rpm	A	kW	rpm	A	kW	rpm	A										
HMCX 80M1-2	0,82	3459	1,54	0,75	2859	1,65	0,75	2873	1,57	7,2	77,4	77,4	77,1	0,89	2,50	3,10	3,23	0,0012	32
HMCX 80M2-2	1,20	3445	2,11	1,10	2836	2,29	1,10	2852	2,18	6,6	79,6	79,7	79,4	0,91	3,70	2,74	2,68	0,0014	34
HMCX 90S-2	1,65	3471	2,84	1,50	2868	3,11	1,50	2881	2,95	7,9	81,3	81,3	81,0	0,90	5,00	3,31	3,70	0,0016	40
HMCX 90L-2	2,40	3474	4,02	2,20	2869	4,45	2,20	2882	4,23	8,5	83,2	83,3	83,0	0,90	7,30	3,77	3,87	0,0018	42
HMCX 100L-2	3,30	3496	5,40	3,00	2892	5,85	3,00	2903	5,56	7,9	84,6	85,2	84,9	0,92	9,90	2,64	3,13	0,0058	63
HMCX 112M-2	4,40	3494	7,17	4,00	2889	7,77	4,00	2900	7,38	6,8	85,8	86,4	86,1	0,91	13,2	2,35	3,48	0,0076	70
HMCX 132S1-2	6,05	3506	9,68	5,50	2902	10,4	5,50	2912	9,91	7,4	87,0	87,0	86,7	0,92	18,0	2,36	3,49	0,0159	80
HMCX 132S2-2	8,25	3504	12,9	7,50	2901	13,9	7,50	2911	13,2	7,5	88,1	88,2	87,9	0,93	24,6	2,44	3,44	0,0195	87
HMCX 160M1-2	12,10	3537	18,7	11,0	2936	20,1	11,0	2942	19,1	8,7	89,4	89,4	89,1	0,93	35,7	2,41	4,24	0,0500	174
HMCX 160M2-2	16,50	3536	25,6	15,0	2935	27,1	15,0	2941	25,8	8,8	90,3	90,3	90,0	0,93	48,7	2,53	4,20	0,0570	184
HMCX 160L-2	20,35	3534	31,0	18,5	2933	32,9	18,5	2940	31,3	8,8	90,9	90,9	90,6	0,94	60,1	2,53	4,10	0,0670	206
HMCX 180M-2	24,20	3547	37,1	22,0	2947	38,9	22,0	2952	37,0	8,7	91,3	91,3	91,0	0,94	71,2	2,11	4,12	0,0980	238
HMCX 200L1-2	33,00	3562	51,3	30,0	2962	53,8	30,0	2966	51,1	6,9	92,0	92,1	91,8	0,92	96,6	2,14	3,38	0,2000	310
HMCX 200L2-2	40,70	3563	62,1	37,0	2962	66,1	37,0	2966	62,8	7,2	92,5	92,5	92,2	0,92	119	2,36	3,47	0,2300	320
HMCX 225M-2	49,50	3561	75,2	45,0	2961	79,0	45,0	2965	75,1	6,5	92,9	93,0	92,7	0,93	145	2,16	2,96	0,4100	460
HMCX 250M-2	60,50	3567	90,8	55,0	2967	96,4	55,0	2970	91,6	7,3	93,2	93,2	92,9	0,93	177	1,79	3,38	0,4800	510
HMCX 280S-2	82,50	3576	124,36	75,0	2976	131	75,0	2978	124	6,8	93,8	93,8	93,5	0,93	241	1,72	3,31	0,8900	630
HMCX 280M-2	99,00	3577	146,23	90,0	2977	156	90,0	2979	148	7,3	94,1	94,1	93,8	0,93	289	1,96	3,55	1,0800	705
HMCX 315S-2	121,0	3576	182,23	110	2976	192	110	2978	183	6,7	94,5	94,5	94,2	0,92	353	1,99	3,36	1,7600	1070
HMCX 315M-2	145,2	3575	216,56	132	2974	230	132	2977	219	6,6	94,6	94,7	94,4	0,92	423	1,99	3,28	1,8800	1100
HMCX 315L1-2	176,0	3575	261,11	160	2974	278	160	2977	265	6,4	94,8	94,9	94,6	0,92	513	2,00	3,20	2,0770	1175
HMCX 315L-2	203,5	3576	301,28	185	2976	322	185	2978	306	6,7	95,0	95,0	94,7	0,92	593	2,14	3,31	2,3500	1235
HMCX 315L2-2	220,0	3577	325,71	200	2977	343	200	2979	326	6,8	95,0	95,2	94,9	0,93	641	2,24	3,34	2,7700	1395
HMCX 355S1-2	203,5	3587	300,96	185	2986	322	185	2987	306	6,8	95,0	95,1	94,6	0,92	591	1,63	3,10	3,4600	1535
HMCX 355S2-2	220,0	3587	321,90	200	2987	340	200	2988	323	6,9	95,0	95,2	94,9	0,94	639	1,68	3,09	4,3800	1690
HMCX 355M1-2	242,0	3586	353,72	220	2986	374	220	2987	355	6,2	95,0	95,1	94,8	0,94	703	1,53	2,80	4,3800	1720
HMCX 355M2-2	275,0	3587	401,96	250	2987	425	250	2988	404	7	95,0	95,1	94,8	0,94	799	1,84	3,07	4,9600	1785
HMCX 355L1-2	308,0	3586	450,67	280	2986	476	280	2987	453	6,3	95,0	95,0	94,7	0,94	895	1,64	2,74	4,9700	1865
HMCX 355L2-2	346,5	3587	505,94	315	2987	535	315	2988	509	6,6	95,0	95,1	94,8	0,94	1007	1,81	2,85	5,9500	2025

IE2 / 4 pole Marine Ex

Motor type	440V 60Hz S1-45°C			380V 50Hz S1-45°C			400V 50Hz S1-45°C			I _s /I _N	Efficiency (%)			Pf cos φ	Torque			IM J(kgm ²)	Weight kg
	P2	Speed	I _N	P2	Speed	I _N	P2	Speed	I _N		¹ / ₁ load	³ / ₄ load	¹ / ₂ load		T _N	T _g / T _N	T _M / T _N		
	kW	rpm	A	kW	rpm	A	kW	rpm	A										
HMCX 80M1-4	0,60	1740	1,30	0,55	1439	1,40	0,55	1445	1,33	6,6	77,1	77,1	76,8	0,77	3,6	3,05	3,69	0,0024	34
HMCX 80M2-4	0,82	1735	1,69	0,75	1435	1,83	0,75	1441	1,74	6,4	79,6	79,7	79,4	0,78	5,0	2,93	3,40	0,0030	36
HMCX 90S-4	1,20	1721	2,27	1,10	1418	2,46	1,10	1426	2,34	5,5	81,4	81,5	81,2	0,83	7,4	2,39	2,82	0,0036	41
HMCX 90L-4	1,65	1715	3,05	1,50	1412	3,26	1,50	1421	3,10	5,8	82,8	83,9	83,7	0,84	10,0	2,40	2,84	0,0045	46
HMCX 100L1-4	2,42	1742	4,13	2,20	1439	4,55	2,20	1445	4,32	6,7	84,3	85,4	85,2	0,87	14,5	2,43	2,92	0,0110	50
HMCX 100L2-4	3,30	1744	5,64	3,00	1441	6,13	3,00	1447	5,82	7,4	85,5	86,6	86,4	0,87	19,8	2,87	3,12	0,0140	55
HMCX 112M-4	4,40	1750	7,41	4,00	1447	8,16	4,00	1452	7,75	8,3	86,6	87,7	87,5	0,86	26,3	3,22	2,97	0,0200	68
HMCX 132S-4	6,05	1755	10,3	5,50	1453	11,1	5,50	1458	10,5	7,7	87,7	87,7	87,4	0,86	36,0	2,66	3,01	0,0330	91
HMCX 132M-4	8,25	1753	13,9	7,50	1452	14,9	7,50	1457	14,2	7,9	88,7	88,7	88,4	0,86	49,2	2,84	2,94	0,0370	98
HMCX 160M-4	12,10	1767	19,6	11,00	1467	20,9	11,00	1470	19,8	7,7	89,8	89,9	89,6	0,89	71,5	2,56	3,31	0,0940	187
HMCX 160L-4	16,50	1768	26,5	15,00	1467	28,6	15,00	1470	27,2	8,2	90,6	91,0	90,8	0,88	97,4	2,86	3,41	0,1100	210
HMCX 180M-4	20,35	1778	32,5	18,50	1478	35,4	18,50	1480	33,7	7,4	91,2	91,2	90,9	0,87	119	2,21	3,19	0,2100	249
HMCX 180L-4	24,20	1777	38,7	22,00	1477	41,5	22,00	1479	39,4	7,2	91,6	91,8	91,4	0,88	142	2,19	3,08	0,2300	267
HMCX 200L-4	33,00	1776	53,0	30,00	1477	56,1	30,00	1479	53,3	6,9	92,3	92,3	92,0	0,88	194	2,53	3,26	0,4200	300
HMCX 225S-4	40,70	1779	63,8	37,00	1479	67,4	37,00	1481	64,0	7,1	92,7	92,7	92,4	0,90	239	1,99	2,70	0,4900	430
HMCX 225M-4	49,50	1778	77,3	45,00	1478	81,6	45,00	1480	77,5	7,0	93,1	93,1	92,8	0,90	290	1,99	2,60	0,5500	460
HMCX 250M-4	60,50	1782	95,9	55,00	1482	103	55,00	1484	97,5	7,3	93,5	93,6	93,3	0,87	354	2,74	2,74	0,8900	520
HMCX 280S-4	82,50	1785	130	75,00	1484	139	75,00	1486	132	6,8	94,0	94,0	93,7	0,87	482	2,50	2,61	1,5500	655
HMCX 280M-4	99,00	1785	156	90,00	1484	165	90,00	1486	157	6,8	94,2	94,2	93,9	0,88	578	2,56	2,57	1,8600	730
HMCX 315S-4	121,0	1787	182	110,0	1487	192	110,0	1488	182	6,6	94,5	94,6	94,3	0,92	706	2,31	2,86	3,5700	1105
HMCX 315M-4	145,2	1789	218	132,0	1489	232	132,0	1490	221	7,7	94,7	94,8	94,5	0,91	846	2,84	3,27	4,2000	1185
HMCX 315L1-4	176,0	1787	265	160,0	1487	278	160,0	1488	264	6,6	94,9	95,0	94,7	0,92	1027	2,44	2,80	4,6600	1270
HMCX 315L-4	203,5	1786	306	185,0	1487	325	185,0	1488	309	6,5	95,1	95,3	95,2	0,91	1188	2,41	2,70	4,8300	1290
HMCX 315L2-4	220,0	1787	330	200,0	1487	347	200,0	1488	330	6,6	95,1	95,2	94,9	0,92	1284	2,50	2,75	5,4200	1420
HMCX 355S1-4	203,5	1790	305	185,0	1490	325	185,0	1491	309	7,4	95,1	95,1	94,7	0,91	1185	2,34	3,12	6,8800	1660
HMCX 355S2-4	220,0	1790	329	200,0	1490	351	200,0	1491	333	7,4	95,1	95,2	94,9	0,91	1281	2,35	3,09	7,6300	1740
HMCX 355M1-4	242,0	1790	361	220,0	1490	386	220,0	1491	367	7,6	95,1	95,2	94,9	0,91	1409	2,47	3,14	8,1700	1775
HMCX 355M2-4	275,0	1790	411	250,0	1490	439	250,0	1491	417	7,5	95,1	95,1	94,8	0,91	1601	2,49	3,07	8,5700	1830
HMCX 355L1-4	308,0	1789	460	280,0	1489	486	280,0	1490	461	6,7	95,1	95,2	94,9	0,92	1795	2,21	2,74	8,5600	1910
HMCX 355L2-4	346,5	1789	518	315,0	1489	547	315,0	1490	520	6,9	95,1	95,1	94,8	0,92	2019	2,30	2,77	9,8500	2040

IE2 / 6 pole Marine Ex

Motor type	440V 60Hz S1-45°C			380V 50Hz S1-45°C			400V 50Hz S1-45°C			I _s /I _N	Efficiency (%)			Pf cos φ	Torque			IM J(kgm ²)	Weight kg
	P2	Speed	I _N	P2	Speed	I _N	P2	Speed	I _N		1/1 load	3/4 load	1/2 load		T _N	T _s / T _N	T _M / T _N		
	kW	rpm	A	kW	rpm	A	kW	rpm	A										
HMCX 80M1-6	0,40	1102	1,12	0,37	903	1,17	0,37	913	1,11	3,0	67,6	67,6	67,3	0,71	3,90	1,70	2,49	0,0031	25
HMCX 80M2-6	0,60	1111	1,59	0,55	916	1,65	0,55	924	1,57	3,3	73,1	73,1	72,8	0,69	5,70	1,87	2,64	0,0040	29
HMCX 90S-6	0,82	1137	1,83	0,75	938	1,92	0,75	944	1,82	4,2	75,9	77,3	76,8	0,78	7,50	2,18	2,34	0,0058	42
HMCX 90L-6	1,21	1139	2,33	1,10	932	2,66	1,10	939	2,53	4,5	78,1	78,2	77,9	0,80	11,2	2,10	2,13	0,0074	47
HMCX 100L-6	1,65	1156	3,26	1,50	951	3,69	1,50	956	3,51	4,8	79,8	80,5	80,2	0,77	15,0	1,91	2,40	0,0160	64
HMCX 112M-6	2,42	1156	4,73	2,20	952	5,18	2,20	957	4,92	4,5	81,8	81,8	81,5	0,76	22,0	1,71	2,17	0,0210	70
HMCX 132S-6	3,30	1160	6,35	3,00	957	7,11	3,00	961	6,75	5,5	83,3	83,3	83,0	0,77	29,8	2,40	2,30	0,0250	82
HMCX 132M1-6	4,40	1159	8,29	4,00	958	9,20	4,00	962	8,74	5,3	84,6	84,6	84,3	0,78	39,7	2,14	2,16	0,0280	95
HMCX 132M2-6	6,05	1163	11,3	5,50	962	12,2	5,50	966	11,6	5,8	86,0	88,0	87,7	0,78	54,4	2,31	2,29	0,0480	105
HMCX 160M-6	8,25	1170	15,0	7,50	970	16,3	7,50	973	15,5	6,0	87,2	87,2	86,9	0,80	73,6	2,40	2,41	0,1200	179
HMCX 160L-6	12,10	1172	21,8	11,00	971	23,3	11,00	974	22,1	6,1	88,7	88,7	88,4	0,81	108	2,37	2,35	0,1700	224
HMCX 180L-6	16,50	1176	28,6	15,00	976	30,2	15,00	978	28,7	4,9	89,7	89,8	89,5	0,84	146	1,94	2,29	0,2700	270
HMCX 200L1-6	20,35	1182	34,3	18,50	982	37,0	18,50	984	35,2	7,0	90,4	90,4	90,1	0,84	180	2,61	2,86	0,4100	285
HMCX 200L2-6	24,20	1182	39,8	22,00	981	43,3	22,00	983	41,1	6,7	90,9	90,9	90,6	0,85	214	2,44	2,68	0,4700	312
HMCX 225M-6	33,00	1185	55,5	30,00	984	59,9	30,00	986	56,9	5,7	91,7	91,9	91,3	0,83	291	2,15	2,50	0,9700	450
HMCX 250M-6	40,70	1188	64,1	37,00	988	69,3	37,00	989	65,8	7,4	92,2	92,2	91,9	0,88	357	2,81	2,89	1,2900	510
HMCX 280S-6	49,50	1189	78,9	45,00	989	84,7	45,00	990	80,4	6,1	92,7	92,8	92,5	0,87	434	2,60	2,24	2,7100	630
HMCX 280M-6	60,50	1190	96,4	55,00	990	102	55,00	991	96,8	6,5	93,1	93,2	92,9	0,88	530	2,82	2,34	3,3500	705
HMCX 315S-6	82,50	1190	131	75,00	990	141	75,00	991	134	7,1	93,7	93,8	93,5	0,86	723	2,39	3,08	4,1200	1090
HMCX 315M-6	99,00	1190	157	90,00	990	167	90,00	991	159	7,0	94,0	94,2	93,9	0,87	868	2,34	2,97	4,8700	1170
HMCX 315L1-6	121,0	1190	190	110,0	990	203	110,0	991	193	7,1	94,3	94,4	94,1	0,87	1061	2,44	2,95	5,4200	1255
HMCX 315L2-6	145,2	1190	228	132,0	990	243	132,0	991	231	7,1	94,7	94,7	94,4	0,87	1273	2,43	2,90	6,4400	1420
HMCX 355S-6	176,0	1193	276	160,0	993	294	160,0	994	280	7,0	94,9	94,9	94,6	0,87	1538	2,13	2,95	10,100	1750
HMCX 355M1-6	203,5	1193	316	185,0	992	336	185,0	993	319	6,6	95,0	95,0	94,7	0,88	1779	2,00	2,77	11,260	1840
HMCX 355M2-6	220,0	1193	341	200,0	993	363	200,0	994	345	6,9	95,0	95,1	94,8	0,88	1922	2,13	2,88	12,450	1930
HMCX 355L1-6	242,0	1193	376	220,0	992	399	220,0	993	379	6,7	95,0	95,1	94,8	0,88	2115	2,07	2,78	13,180	2075
HMCX 355L2-6	275,0	1193	427	250,0	993	453	250,0	994	431	6,8	95,0	95,2	94,9	0,88	2403	2,14	2,81	14,820	2195

IE2 / 8 pole Marine Ex

Motor type	440V 60Hz S1-45°C			380V 50Hz S1-45°C			400V 50Hz S1-45°C			I _s /I _N	Efficiency (%)			Pf cos φ	Torque			IM J(kgm ²)	Weight kg
	P2	Speed	I _N	P2	Speed	I _N	P2	Speed	I _N		¹ / ₂ load	³ / ₄ load	¹ / ₂ load		T _N	T _s / T _N	T _M / T _N		
	kW	rpm	A	kW	rpm	A	kW	rpm	A										
HMCX 100L1-8	0,82	838	2,08	0,75	687	2,20	0,75	693	2,09	3,5	66,4	67,3	67,1	0,78	10,3	1,90	2,50	0,0120	65
HMCX 100L2-8	1,21	859	2,93	1,10	706	3,32	1,10	710	3,15	4,7	70,8	71,9	71,7	0,71	14,8	2,99	3,42	0,0160	72
HMCX 112M-8	1,65	865	3,60	1,50	710	4,20	1,50	714	3,99	4,3	74,2	75,2	75,0	0,73	20,1	2,13	2,91	0,0230	82
HMCX 132S-8	2,42	855	5,00	2,20	700	5,65	2,20	705	5,37	3,8	77,7	78,7	78,5	0,76	29,8	1,77	2,41	0,0290	103
HMCX 132M-8	3,30	859	6,79	3,00	706	7,68	3,00	710	7,30	4,2	80,0	81,1	80,9	0,74	40,4	1,95	2,61	0,0400	122
HMCX 160M1-8	4,40	876	8,83	4,00	724	9,84	4,00	727	9,35	5,3	81,9	82,4	81,9	0,75	52,5	2,12	2,78	0,0820	155
HMCX 160M2-8	6,05	873	11,8	5,50	722	12,9	5,50	725	12,3	5,0	83,8	84,3	83,8	0,77	72,4	1,87	2,46	0,1000	169
HMCX 160L-8	8,25	875	15,8	7,50	723	17,3	7,50	726	16,5	5,1	85,3	85,8	85,3	0,78	98,7	1,82	2,45	0,1400	206
HMCX 180L-8	12,10	882	23,3	11,00	731	26,0	11,00	733	24,7	5,7	86,9	87,4	86,9	0,74	143	1,91	2,80	0,2600	268
HMCX 200L-8	16,50	884	31,1	15,00	733	33,6	15,00	735	32,0	5,9	88,0	88,5	88,0	0,77	195	1,88	2,61	0,5100	359
HMCX 225S-8	20,35	887	37,4	18,50	737	40,7	18,50	738	38,6	5,6	88,6	88,6	88,1	0,78	239	1,62	2,41	0,7600	392
HMCX 225M-8	24,20	887	43,7	22,00	737	47,4	22,00	738	45,1	5,6	89,1	89,1	88,6	0,79	285	1,63	2,36	0,8700	431
HMCX 250M-8	33,00	887	58,2	30,00	737	62,6	30,00	738	59,5	5,4	89,9	89,8	89,3	0,81	388	2,21	2,55	1,3400	480
HMCX 280S-8	40,70	891	68,7	37,00	741	75,0	37,00	742	71,3	5,7	90,3	90,3	89,8	0,83	476	2,08	2,35	2,4800	615
HMCX 280M-8	49,50	891	83,5	45,00	741	89,7	45,00	742	85,3	6,0	90,7	90,7	90,2	0,84	579	2,22	2,41	3,0000	630
HMCX 315S-8	60,50	890	102	55,00	739	111	55,00	740	105	5,6	91,0	91,0	90,5	0,83	710	1,71	2,68	4,4100	1045
HMCX 315M-8	82,50	890	139	75,00	740	150	75,00	741	142	6,0	91,6	91,6	91,1	0,83	967	1,92	2,78	5,6600	1155
HMCX 315L1-8	99,00	890	165	90,00	740	179	90,00	741	170	6,2	91,9	91,9	91,4	0,83	1160	1,99	2,82	6,7400	1280
HMCX 315L2-8	121,0	890	200	110,0	740	216	110,0	741	205	6,0	92,3	92,3	91,8	0,84	1418	1,91	2,69	8,0000	1440
HMCX 355S-8	145,2	895	248	132,0	744	271	132,0	745	257	5,8	92,6	92,5	91,8	0,80	1692	2,34	2,44	12,690	1790
HMCX 355M-8	176,0	895	297	160,0	744	323	160,0	745	307	5,6	93,0	92,9	92,2	0,81	2051	2,20	2,28	14,510	1910
HMCX 355L1-8	203,5	895	348	185,0	746	376	185,0	746	357	6,1	93,3	93,3	92,5	0,80	2368	2,59	2,49	16,090	2080
HMCX 355L2-8	220,0	895	374	200,0	746	406	200,0	746	386	6,2	93,5	93,4	92,7	0,80	2560	2,65	2,51	17,520	2180

B3

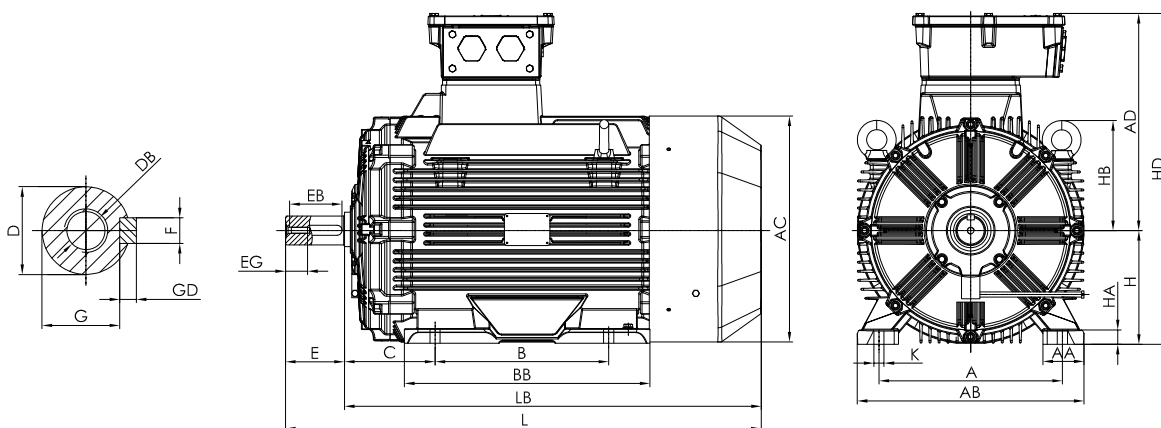

Motor type	Pole	db/db eb								Terminal board	db/db eb														
		AC	AD	C	L	LB	H	HB	HD		Thread	D	E	F	G	GD	EB	EG	DB	A	AA	AB	B	BB	HA
HMCX 80M	2,4,6	156	175/175	50	360	320	80	82	255	M5	19	40	6	15,5	6	32	20	M6	125	32	157	100	160	10	10
HMCX 90S	2,4,6	173	185/185	56	400	350	90	100	275	M5	24	50	8	20	7	40	22	M8	140	37	172	100	164	12	10
HMCX 90L	2,4,6	173	185/185	56	425	375	90	100	275	M5	24	50	8	20	7	40	22	M8	140	37	172	125	200	12	10
HMCX 100L	2,4,6,8	203	203/203	63	465	405	100	105	303	M5	28	60	8	24	7	50	22	M10	160	45	200	140	215	15	12
HMCX 112M	2,4,6,8	221	211/211	70	485	425	112	110	323	M5	28	60	8	24	7	50	22	M10	190	45,5	228	140	210	15	12
HMCX 132S	2,4,6,8	247	260/260	89	515	435	132	125	392	M6	38	80	10	33	8	70	28	M12	216	56,5	262	140	250	18	12
HMCX 132M	2,4,6,8	247	260/260	89	565	485	132	125	392	M6	38	80	10	33	8	70	28	M12	216	56,5	262	178	285	18	12
HMCX 160M	2,4,6,8	312	290/290	108	670	560	160	155	450	M6	42	110	12	37	8	90	28	M12	254	65	314	210	320	20	14,5
HMCX 160L	2,4,6,8	312	290/290	108	730	620	160	155	450	M6	42	110	12	37	8	90	28	M12	254	65	314	254	380	20	14,5
HMCX 180M	2,4	354	362/372	121	690	580	180	170	542/552	M8	48	110	14	42,5	9	100	36	M16	279	68	349	241	350	22	14,5
HMCX 180L	4,6,8	354	362/372	121	690	580	180	170	542/552	M8	48	110	14	42,5	9	100	36	M16	279	68	349	279	350	22	14,5
HMCX 200L	2,4,6,8	396	382/392	133	830	720	200	195	582/592	M8	55	110	16	49	10	100	42	M20	318	84	388	305	400	25	18,5
HMCX 225S	4,8	445	402/450	149	925	785	225	205	627/675	M8	60	140	18	53	11	125	42	M20	356	84	431	286	425	28	18,5
HMCX 225M	2	445	402/450	149	935	825	225	205	627/675	M8	55	110	16	49	10	100	42	M20	356	84	431	311	465	28	18,5
HMCX 225M	4,6,8	445	402/450	149	965	825	225	205	627/675	M8	60	140	18	53	11	125	42	M20	356	84	431	311	465	28	18,5
HMCX 250M	2	496	482/485	168	968	828	250	230	732/735	M8	60	140	18	53	11	125	42	M20	406	82	484	349	465	30	24
HMCX 250M	4,6,8	496	482/485	168	968	828	250	230	732/735	M8	65	140	18	58	11	125	42	M20	406	82	484	349	465	30	24

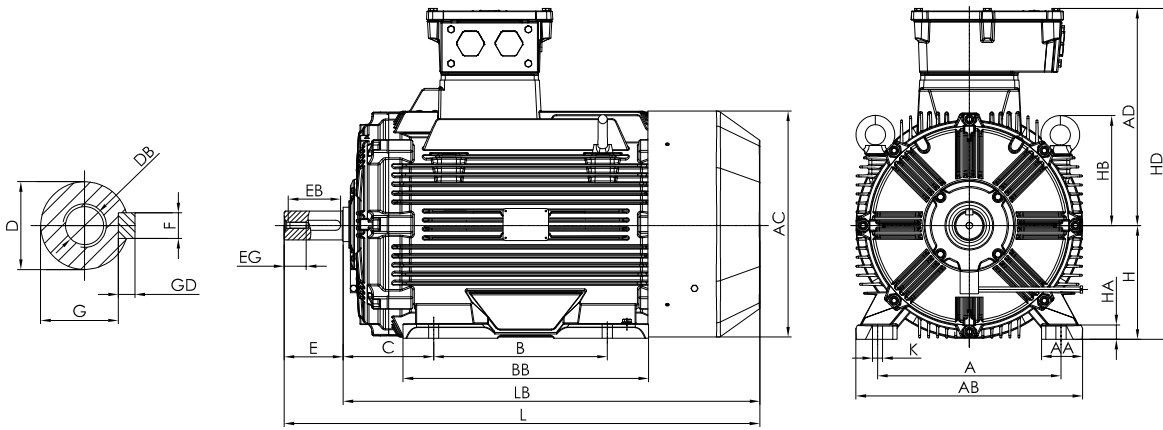

Motor type	Pole	db/db eb								Terminal board	db/db eb														
		AC	AD	C	L	LB	H	HB	HD		Thread	D	E	F	G	GD	EB	EG	DB	A	AA	AB	B	BB	HA
HMCX 280S	2	555	512/515	190	1065	925	280	250	792/795	M12	65	140	18	58	11	125	42	M20	457	89	542	368	495	34	24
HMCX 280S	4,6,8	555	512/515	190	1065	925	280	250	792/795	M12	75	140	20	67,5	12	125	42	M20	457	89	542	368	495	34	24
HMCX 280M	2	555	512/515	190	1115	975	280	250	792/795	M12	65	140	18	58	11	125	42	M20	457	89	542	419	545	34	24
HMCX 280M	4,6,8	555	512/515	190	1115	975	280	250	792/795	M12	75	140	20	67,5	12	125	42	M20	457	89	542	419	545	34	24
HMCX 315S	2	626	600/649	216	1260	1120	315	305	915/964	M12	65	140	18	58	11	125	42	M20	508	114	628	406	620	40	28
HMCX 315S	4,6,8	626	600/649	216	1290	1120	315	305	915/964	M12	80	170	22	71	14	140	42	M20	508	114	628	406	620	40	28
HMCX 315M	2	626	600/649	216	1260	1120	315	305	915/964	M12	65	140	18	58	11	125	42	M20	508	114	628	457	620	40	28
HMCX 315M	4,6,8	626	600/649	216	1290	1120	315	305	915/964	M12	80	170	22	71	14	140	42	M20	508	114	628	457	620	40	28
HMCX 315L1	2	626	600/649	216	1320	1180	315	305	915/964	M12	65	140	18	58	11	140	42	M20	508	114	628	508	680	40	28
HMCX 315L,L2	2	626	600/649	216	1445	1305	315	305	915/964	M12	65	140	18	58	11	125	42	M20	508	114	628	508	800	40	28
HMCX 315L1	4,6,8	626	600/649	216	1350	1180	315	305	915/964	M12	80	170	22	71	14	140	42	M20	508	114	628	580	680	40	28
HMCX 315L,L2	4,6,8	626	600/649	216	1475	1305	315	305	915/964	M12	80	170	22	71	14	140	42	M20	508	114	628	508	800	40	28
HMCX 355S	2	711	740/815	254	1530	1390	355	352	1095/1170	M16	75	140	20	67,5	12	125	50	M24	610	146	740	500	810	45	28
HMCX 355S	4,6,8	711	740/815	254	1560	1390	355	352	1095/1170	M16	95	170	25	86	14	140	50	M24	610	146	740	500	810	45	28
HMCX 355M	2	711	740/815	254	1530	1390	355	352	1095/1170	M16	75	140	20	67,5	12	125	50	M24	610	146	740	560	810	45	28
HMCX 355M	4,6,8	711	740/815	254	1560	1390	355	352	1095/1170	M16	95	170	25	86	14	140	50	M24	610	146	740	560	810	45	28
HMCX 355L	2	711	740/815	254	1690	1550	355	352	1095/1170	M16	75	140	20	67,5	12	125	50	M24	610	146	740	630	920	45	28
HMCX 355L	4,6,8	711	740/815	254	1720	1550	355	352	1095/1170	M16	95	170	25	86	14	140	50	M24	610	146	740	630	920	45	28

B5

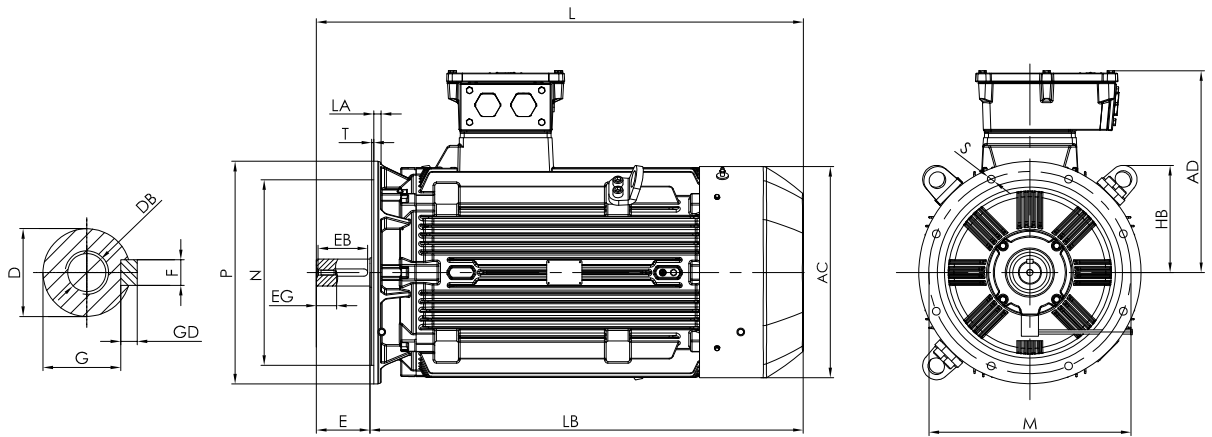

Motor type	Pole	AC	db/ db eb				Ter- minal board														
				AD	L	LB		HB	Thread	D	E	F	G	GD	EB	EG	DB	M	N	P	S
HMCX 80M	2,4,6	156	175/175	360	320	85	M5	19	40	6	15,5	6	32	20	M6	165	130	200	12	3,5	12
HMCX 90S	2,4,6	173	185/185	425	375	90	M5	24	50	8	20	7	40	22	M8	165	130	200	12	3,5	10
HMCX 90L	2,4,6	173	185/185	425	375	90	M5	24	50	8	20	7	40	22	M8	165	130	200	12	3,5	10
HMCX 100L	2,4,6,8	203	203/203	465	405	110	M5	28	60	8	24	7	50	22	M10	215	180	250	14,5	4	13
HMCX 112M	2,4,6,8	221	211/211	485	425	115	M5	28	60	8	24	7	50	22	M10	215	180	250	14,5	4	13
HMCX 132S	2,4,6,8	247	260/260	515	435	135	M6	38	80	10	33	8	70	28	M12	265	230	300	14,5	4	16
HMCX 132M	2,4,6,8	247	260/260	565	485	135	M6	38	80	10	33	8	70	28	M12	265	230	300	14,5	4	16
HMCX 160M	2,4,6,8	312	290/290	670	560	165	M6	42	110	12	37	8	90	28	M12	300	250	350	18,5	5	16
HMCX 160L	2,4,6,8	312	290/290	730	620	165	M6	42	110	12	37	8	90	28	M12	300	250	350	18,5	5	16
HMCX 180M	2,4	354	362/372	690	580	180	M8	48	110	14	42,5	9	100	36	M16	300	250	350	18,5	5	15
HMCX 180L	4,6,8	354	362/372	690	580	180	M8	48	110	14	42,5	9	100	36	M16	300	250	350	18,5	5	15
HMCX 200L	2,4,6,8	396	382/392	830	720	200	M8	55	110	16	49	10	100	42	M20	350	300	400	18,5	5	17
HMCX 225S	4,8	445	402/450	965	825	215	M8	60	140	18	53	11	125	42	M20	400	350	450	18,5	5	22
HMCX 225M	2	445	402/450	935	825	215	M8	55	110	16	49	10	100	42	M20	400	350	450	18,5	5	22
HMCX 225M	4,6,8	445	402/450	965	825	215	M8	60	140	18	53	11	125	42	M20	400	350	450	18,5	5	22
HMCX 250M	2	496	482/485	968	828	255	M8	60	140	18	53	11	125	42	M20	500	450	550	18,5	5	22
HMCX 250M	4,6,8	496	482/485	968	828	255	M8	65	140	18	58	11	125	42	M20	500	450	550	18,5	5	22

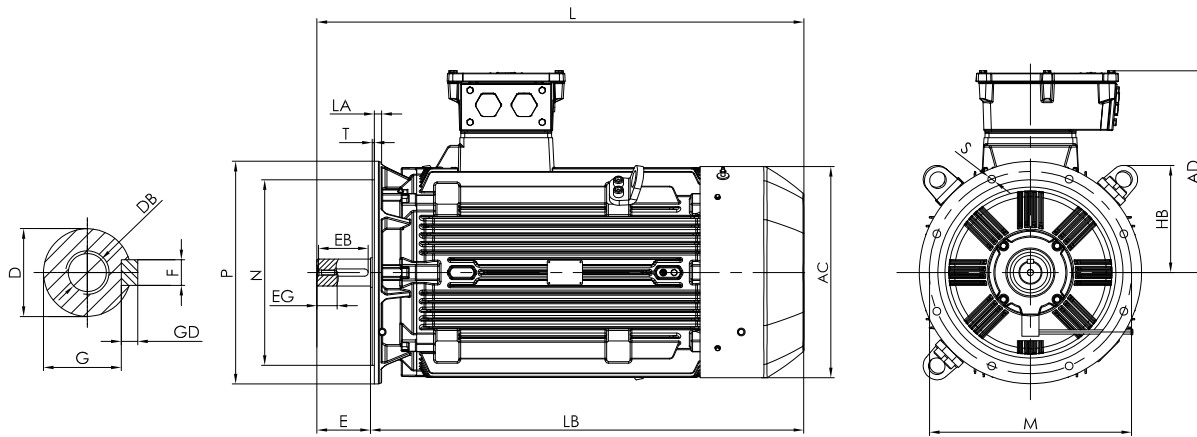

Motor type	Pole	AC	db/ db eb				Ter- minal board														
				AD	L	LB		HB	Thread	D	E	F	G	GD	EB	EG	DB	M	N	P	S
HMCX 280S	2	555	512/515	1115	975	270	M12	65	140	18	58	11	125	42	M20	500	450	550	18,5	5	22
HMCX 280S	4,6,8	555	512/515	1115	975	270	M12	75	140	20	67,5	12	125	42	M20	500	450	550	18,5	5	22
HMCX 280M	2	555	512/515	1115	975	270	M12	65	140	18	58	11	125	42	M20	500	450	550	18,5	5	22
HMCX 280M	4,6,8	555	512/515	1115	975	270	M12	75	140	20	67,5	12	125	42	M20	500	450	550	18,5	5	22
HMCX 315S	2	626	600/649	1325	1185	320	M12	65	140	18	58	11	125	42	M20	600	550	660	24	6	22
HMCX 315S	4,6,8	626	600/649	1355	1185	320	M12	80	170	22	71	14	140	42	M20	600	550	660	24	6	22
HMCX 315M	2	626	600/649	1325	1185	320	M12	65	140	18	58	11	125	42	M20	600	550	660	24	6	22
HMCX 315M	4,6,8	626	600/649	1355	1185	320	M12	80	170	22	71	14	140	42	M20	600	550	660	24	6	22
HMCX 315L1	2	626	600/649	1445	1305	320	M12	65	140	18	58	11	140	42	M20	600	550	660	24	6	22
HMCX 315L,L2	2	626	600/649	1445	1305	320	M12	65	140	18	58	11	125	42	M20	600	550	660	24	6	22
HMCX 315L1	4,6,8	626	600/649	1475	1305	320	M12	80	170	22	71	14	140	42	M20	600	550	660	24	6	22
HMCX 315L,L2	4,6,8	626	600/649	1475	1305	320	M12	80	170	22	71	14	140	42	M20	600	550	660	24	6	22
HMCX 355S	2	711	740/815	1530	1390	300	M16	75	140	20	67,5	12	125	50	M24	740	680	800	24	6	25
HMCX 355S	4,6,8	711	740/815	1560	1390	300	M16	95	170	25	86	14	140	50	M24	740	680	800	24	6	25
HMCX 355M	2	711	740/815	1530	1390	300	M16	75	140	20	67,5	12	125	50	M24	740	680	800	24	6	25
HMCX 355M	4,6,8	711	740/815	1560	1390	300	M16	95	170	25	86	14	140	50	M24	740	680	800	24	6	25
HMCX 355L	2	711	740/815	1690	1550	300	M16	75	140	20	67,5	12	125	50	M24	740	680	800	24	6	25
HMCX 355L	4,6,8	711	740/815	1720	1550	300	M16	95	170	25	86	14	140	50	M24	740	680	800	24	6	25

B35

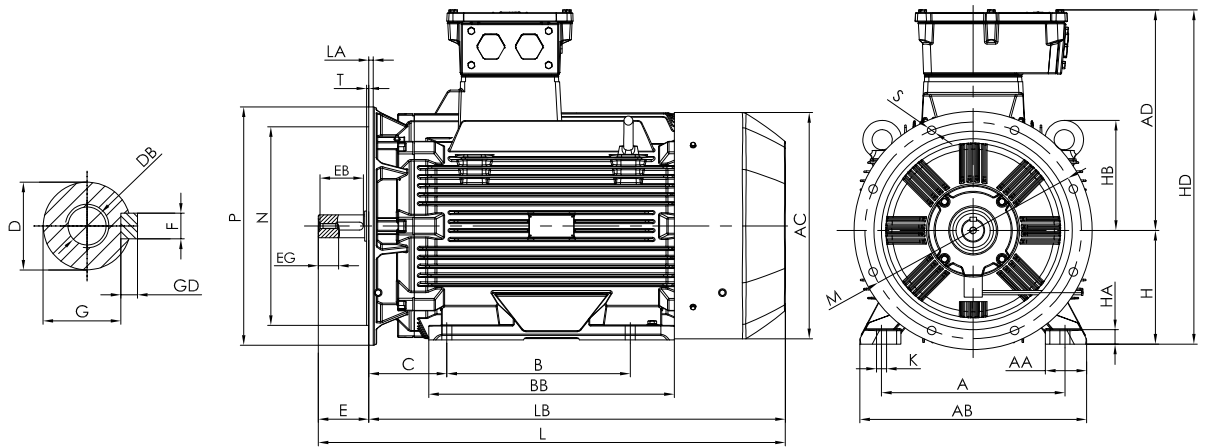

Motor type	Pole	db/db eb								Terminal board	db/db eb																				
		AC	AD	C	L	LB	H	HB	HD		Thread	D	E	F	G	GD	EB	EG	DB	A	AA	AB	B	BB	HA	K	M	N	P	S	T
HMCX 80M	2,4,6	156	175/175	50	360	320	80	82	255	M5	19	40	6	15,5	6	32	20	M6	125	32	157	100	160	10	10	165	130	200	12	3,5	12
HMCX 90S	2,4,6	173	185/185	56	400	350	90	100	275	M5	24	50	8	20	7	40	22	M8	140	37	172	100	164	12	10	165	130	200	12	3,5	10
HMCX 90L	2,4,6	173	185/185	56	425	375	90	100	275	M5	24	50	8	20	7	40	22	M8	140	37	172	125	200	12	10	165	130	200	12	3,5	10
HMCX 100L	2,4,6,8	203	203/203	63	465	405	100	105	303	M5	28	60	8	24	7	50	22	M10	160	45	200	140	215	15	12	215	180	250	14,5	4	13
HMCX 112M	2,4,6,8	221	211/211	70	485	425	112	110	323	M5	28	60	8	24	7	50	22	M10	190	45,5	228	140	210	15	12	215	180	250	14,5	4	13
HMCX 132S	2,4,6,8	247	260/260	89	515	435	132	125	392	M6	38	80	10	33	8	70	28	M12	216	56,5	262	140	250	18	12	265	230	300	14,5	4	16
HMCX 132M	2,4,6,8	247	260/260	89	565	485	132	125	392	M6	38	80	10	33	8	70	28	M12	216	56,5	262	178	285	18	12	265	230	300	14,5	4	16
HMCX 160M	2,4,6,8	312	290/290	108	670	560	160	155	450	M6	42	110	12	37	8	90	28	M12	254	65	314	210	320	20	14,5	300	250	350	18,5	5	16
HMCX 160L	2,4,6,8	312	290/290	108	730	620	160	155	450	M6	42	110	12	37	8	90	28	M12	254	65	314	254	380	20	14,5	300	250	350	18,5	5	16
HMCX 180M	2,4	354	362/372	121	690	580	180	170	542/552	M8	48	110	14	42,5	9	100	36	M16	279	68	349	241	350	22	14,5	300	250	350	18,5	5	15
HMCX 180L	4,6,8	354	362/372	121	690	580	180	170	542/552	M8	48	110	14	42,5	9	100	36	M16	279	68	349	279	350	22	14,5	300	250	350	18,5	5	15
HMCX 200L	2,4,6,8	396	382/392	133	830	720	200	195	582/592	M8	55	110	16	49	10	100	42	M20	318	84	388	305	400	25	18,5	350	300	400	18,5	5	17
HMCX 225S	4,8	445	402/450	149	925	785	225	205	627/675	M8	60	140	18	53	11	125	42	M20	356	84	431	286	425	28	18,5	400	350	450	18,5	5	22
HMCX 225M	2	445	402/450	149	935	825	225	205	627/675	M8	55	110	16	49	10	100	42	M20	356	84	431	311	465	28	18,5	400	350	450	18,5	5	22
HMCX 225M	4,6,8	445	402/450	149	965	825	225	205	627/675	M8	60	140	18	53	11	125	42	M20	356	84	431	311	465	28	18,5	400	350	450	18,5	5	22
HMCX 250M	2	496	482/485	168	968	828	250	230	732/735	M8	60	140	18	53	11	125	42	M20	406	82	484	349	465	30	24	500	450	550	18,5	5	22
HMCX 250M	4,6,8	496	482/485	168	968	828	250	230	732/735	M8	65	140	18	58	11	125	42	M20	406	82	484	349	465	30	24	500	450	550	18,5	5	22

B35

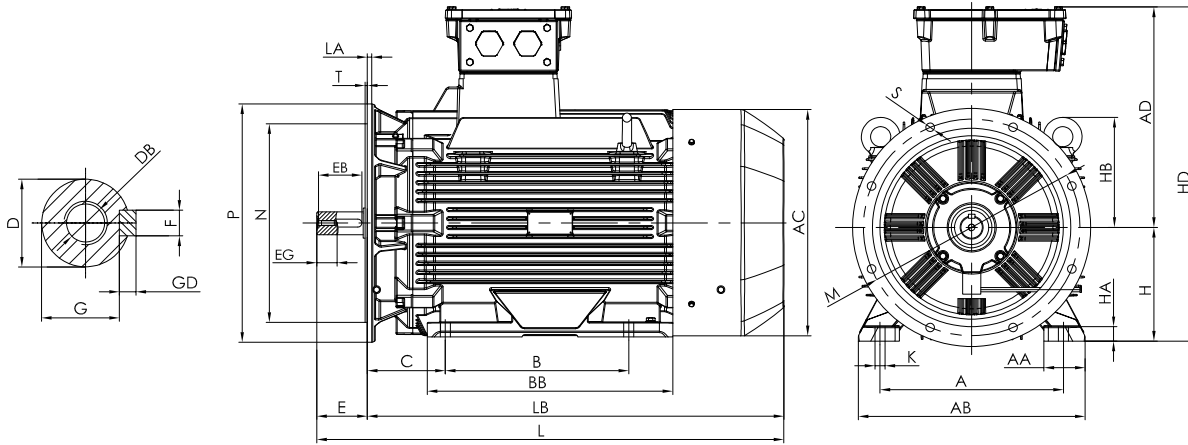

Motor type	Pole	AC	db/db eb					db/db eb	Ter- minal board																						
			AD	C	L	LB	H			HB	HD	Thread	D	E	F	G	GD	EB	EG	DB	A	AA	AB	B	BB	HA	K	M	N	P	S
HMCX 280S	2	555	512/515	190	1065	925	280	250	792/795	M12	65	140	18	58	11	125	42	M20	457	89	542	368	495	34	24	500	450	550	18,5	5	22
HMCX 280S	4,6,8	555	512/515	190	1065	925	280	250	792/795	M12	75	140	20	67,5	12	125	42	M20	457	89	542	368	495	34	24	500	450	550	18,5	5	22
HMCX 280M	2	555	512/515	190	1115	975	280	250	792/795	M12	65	140	18	58	11	125	42	M20	457	89	542	419	545	34	24	500	450	550	18,5	5	22
HMCX 280M	4,6,8	555	512/515	190	1115	975	280	250	792/795	M12	75	140	20	67,5	12	125	42	M20	457	89	542	419	545	34	24	500	450	550	18,5	5	22
HMCX 315S	2	626	600/649	216	1260	1120	315	305	915/964	M12	65	140	18	58	11	125	42	M20	508	114	628	406	620	40	28	600	550	660	24	6	22
HMCX 315S	4,6,8	626	600/649	216	1290	1120	315	305	915/964	M12	80	170	22	71	14	140	42	M20	508	114	628	406	620	40	28	600	550	660	24	6	22
HMCX 315M	2	626	600/649	216	1260	1120	315	305	915/964	M12	65	140	18	58	11	125	42	M20	508	114	628	457	620	40	28	600	550	660	24	6	22
HMCX 315M	4,6,8	626	600/649	216	1290	1120	315	305	915/964	M12	80	170	22	71	14	140	42	M20	508	114	628	457	620	40	28	600	550	660	24	6	22
HMCX 315L1	2	626	600/649	216	1320	1180	315	305	915/964	M12	65	140	18	58	11	140	42	M20	508	114	628	508	680	40	28	600	550	660	24	6	22
HMCX 315L,L2	2	626	600/649	216	1445	1305	315	305	915/964	M12	65	140	18	58	11	125	42	M20	508	114	628	508	800	40	28	600	550	660	24	6	22
HMCX 315L1	4,6,8	626	600/649	216	1350	1180	315	305	915/964	M12	80	170	22	71	14	140	42	M20	508	114	628	508	680	40	28	600	550	660	24	6	22
HMCX 315L,L2	4,6,8	626	600/649	216	1475	1305	315	305	915/964	M12	80	170	22	71	14	140	42	M20	508	114	628	508	800	40	28	600	550	660	24	6	22
HMCX 355S	2	711	740/815	254	1530	1390	355	352	1095/1170	M16	75	140	20	67,5	12	125	50	M24	610	146	740	500	810	45	28	740	680	800	24	6	25
HMCX 355S	4,6,8	711	740/815	254	1560	1390	355	352	1095/1170	M16	95	170	25	86	14	140	50	M24	610	146	740	500	810	45	28	740	680	800	24	6	25
HMCX 355M	2	711	740/815	254	1530	1390	355	352	1095/1170	M16	75	140	20	67,5	12	125	50	M24	610	146	740	560	810	45	28	740	680	800	24	6	25
HMCX 355M	4,6,8	711	740/815	254	1560	1390	355	352	1095/1170	M16	95	170	25	86	14	140	50	M24	610	146	740	560	810	45	28	740	680	800	24	6	25
HMCX 355L	2	711	740/815	254	1690	1550	355	352	1095/1170	M16	75	140	20	67,5	12	125	50	M24	610	146	740	630	920	45	28	740	680	800	24	6	25
HMCX 355L	4,6,8	711	740/815	254	1720	1550	355	352	1095/1170	M16	95	170	25	86	14	140	50	M24	610	146	740	630	920	45	28	740	680	800	24	6	25

V1RC Open deck design

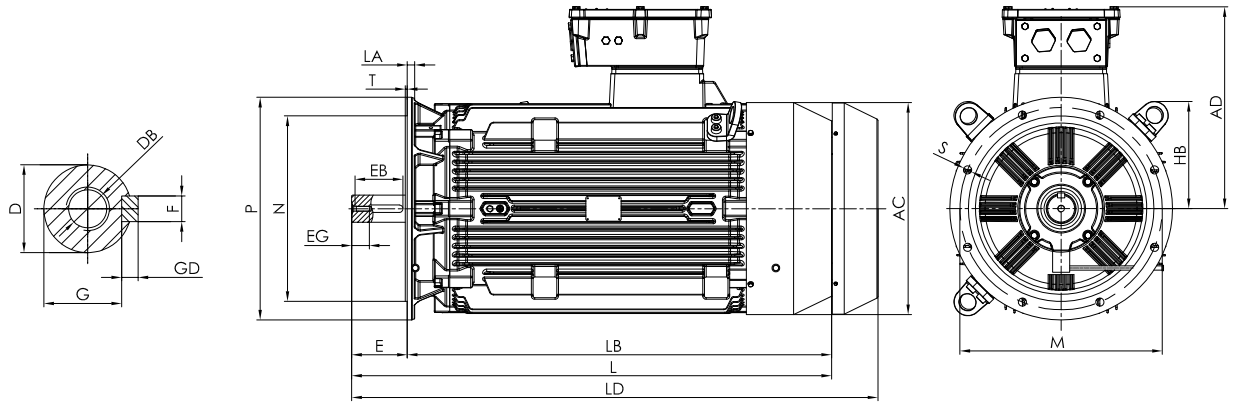

Motor type	Pole	AC	db/ db eb					Ter- minal board														
			AD	L	LB	LD	HB	Thread	D	E	F	G	GD	EB	EG	DB	M	N	P	S	T	LA
HMCX 80M	2,4,6	156	175/175	360	320	385	85	M5	19	40	6	15,5	6	32	20	M6	165	130	200	12	3,5	12
HMCX 90S	2,4,6	173	185/185	425	375	455	90	M5	24	50	8	20	7	40	22	M8	165	130	200	12	3,5	10
HMCX 90L	2,4,6	173	185/185	425	375	455	90	M5	24	50	8	20	7	40	22	M8	165	130	200	12	3,5	10
HMCX 100L	2,4,6,8	203	203/203	465	405	490	110	M5	28	60	8	24	7	50	22	M10	215	180	250	14,5	4	13
HMCX 112M	2,4,6,8	221	211/211	485	425	520	115	M5	28	60	8	24	7	50	22	M10	215	180	250	14,5	4	13
HMCX 132S	2,4,6,8	247	260/260	515	435	560	135	M6	38	80	10	33	8	70	28	M12	265	230	300	14,5	4	16
HMCX 132M	2,4,6,8	247	260/260	565	485	610	135	M6	38	80	10	33	8	70	28	M12	265	230	300	14,5	4	16
HMCX 160M	2,4,6,8	312	290/290	670	560	730	165	M6	42	110	12	37	8	90	28	M12	300	250	350	18,5	5	16
HMCX 160L	2,4,6,8	312	290/290	730	620	790	165	M6	42	110	12	37	8	90	28	M12	300	250	350	18,5	5	16
HMCX 180M	2,4	354	362/372	690	580	750	180	M8	48	110	14	42,5	9	100	36	M16	300	250	350	18,5	5	15
HMCX 180L	4,6,8	354	362/372	690	580	750	180	M8	48	110	14	42,5	9	100	36	M16	300	250	350	18,5	5	15
HMCX 200L	2,4,6,8	396	382/392	830	720	910	200	M8	55	110	16	49	10	100	42	M20	350	300	400	18,5	5	17
HMCX 225S	4,8	445	402/450	965	825	1020	215	M8	60	140	18	53	11	125	42	M20	400	350	450	18,5	5	22
HMCX 225M	2	445	402/450	935	825	990	215	M8	55	110	16	49	10	100	42	M20	400	350	450	18,5	5	22
HMCX 225M	4,6,8	445	402/450	965	825	1020	215	M8	60	140	18	53	11	125	42	M20	400	350	450	18,5	5	22
HMCX 250M	2	496	482/485	968	828	1050	255	M8	60	140	18	53	11	125	42	M20	500	450	550	18,5	5	22
HMCX 250M	4,6,8	496	482/485	968	828	1050	255	M8	65	140	18	58	11	125	42	M20	500	450	550	18,5	5	22

V1RC Open deck design

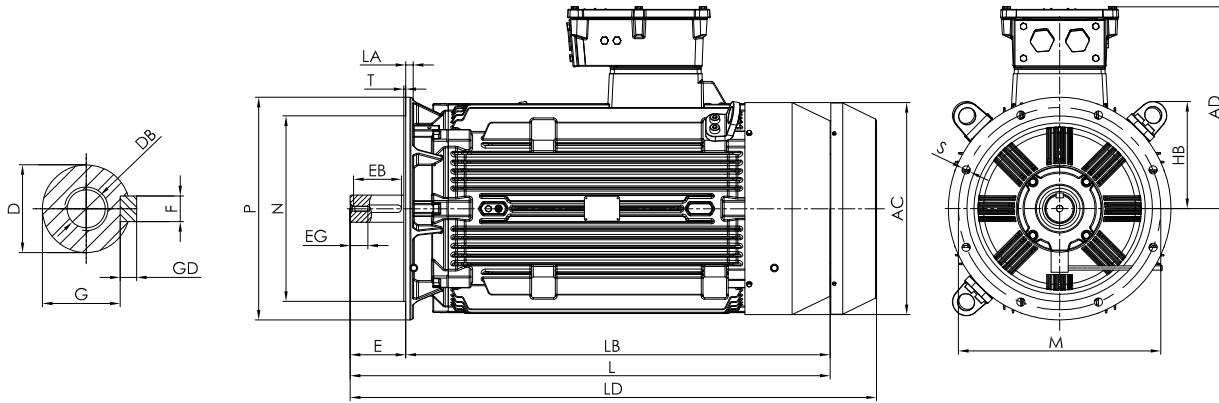

Motor type	Pole	AC	db/db eb		Terminal board																	
			AD	L	LB	LD	HB	Thread	D	E	F	G	GD	EB	EG	DB	M	N	P	S	T	LA
HMCX 280S	2	555	512/515	1115	945	1195	270	M12	65	140	18	58	11	125	42	M20	500	450	550	18,5	5	22
HMCX 280S	4,6,8	555	512/515	1115	975	1165	270	M12	75	140	20	67,5	12	125	42	M20	500	450	550	18,5	5	22
HMCX 280M	2	555	512/515	1115	975	1195	270	M12	65	140	18	58	11	125	42	M20	500	450	550	18,5	5	22
HMCX 280M	4,6,8	555	512/515	1115	975	1195	270	M12	75	140	20	67,5	12	125	42	M20	500	450	550	18,5	5	22
HMCX 315S	2	626	600/649	1325	1185	1405	320	M12	65	140	18	58	11	125	42	M20	600	550	660	24	6	22
HMCX 315S	4,6,8	626	600/649	1355	1185	1435	320	M12	80	170	22	71	14	140	42	M20	600	550	660	24	6	22
HMCX 315M	2	626	600/649	1325	1185	1405	320	M12	65	140	18	58	11	125	42	M20	600	550	660	24	6	22
HMCX 315M	4,6,8	626	600/649	1355	1185	1435	320	M12	80	170	22	71	14	140	42	M20	600	550	660	24	6	22
HMCX 315L1	2	626	600/649	1445	1305	1525	320	M12	65	140	18	58	11	140	42	M20	600	550	660	24	6	22
HMCX 315L,L2	2	626	600/649	1445	1305	1525	320	M12	65	140	18	58	11	125	42	M20	600	550	660	24	6	22
HMCX 315L1	4,6,8	626	600/649	1475	1305	1555	320	M12	80	170	22	71	14	140	42	M20	600	550	660	24	6	22
HMCX 315L,L2	4,6,8	626	600/649	1475	1305	1555	320	M12	80	170	22	71	14	140	42	M20	600	550	660	24	6	22
HMCX 355S	2	711	740/815	1530	1390	1610	300	M16	75	140	20	67,5	12	125	50	M24	740	680	800	24	6	25
HMCX 355S	4,6,8	711	740/815	1560	1390	1640	300	M16	95	170	25	86	14	140	50	M24	740	680	800	24	6	25
HMCX 355M	2	711	740/815	1530	1390	1610	300	M16	75	140	20	67,5	12	125	50	M24	740	680	800	24	6	25
HMCX 355M	4,6,8	711	740/815	1560	1390	1640	300	M16	95	170	25	86	14	140	50	M24	740	680	800	24	6	25
HMCX 355L	2	711	740/815	1690	1550	1770	300	M16	75	140	20	67,5	12	125	50	M24	740	680	800	24	6	25
HMCX 355L	4,6,8	711	740/815	1720	1550	1800	300	M16	95	170	25	86	14	140	50	M24	740	680	800	24	6	25